

**ARCHITECTURAL STRUCTURES I:  
STATICS AND STRENGTH OF MATERIALS**

---

**ENDS 231**

**DR. ANNE NICHOLS**

**SPRING 2008**

*lecture*  
**twenty three**



***stability and columns***

# Additional Design Criteria

- designed for strength & stresses
- designed for serviceability & deflection
- need to design for stability
  - ability to support a specified load without sudden or unacceptable deformations

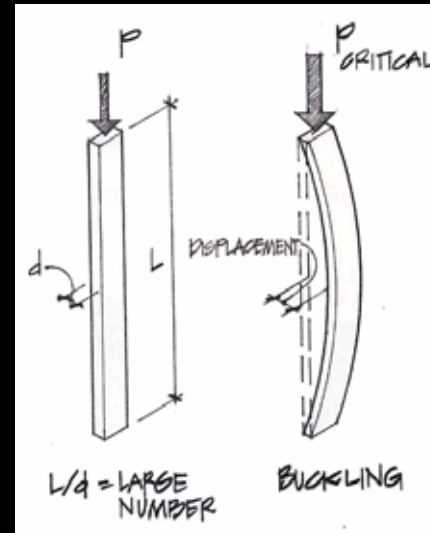

# Column Behavior

---

- *objects like lowest energy state*

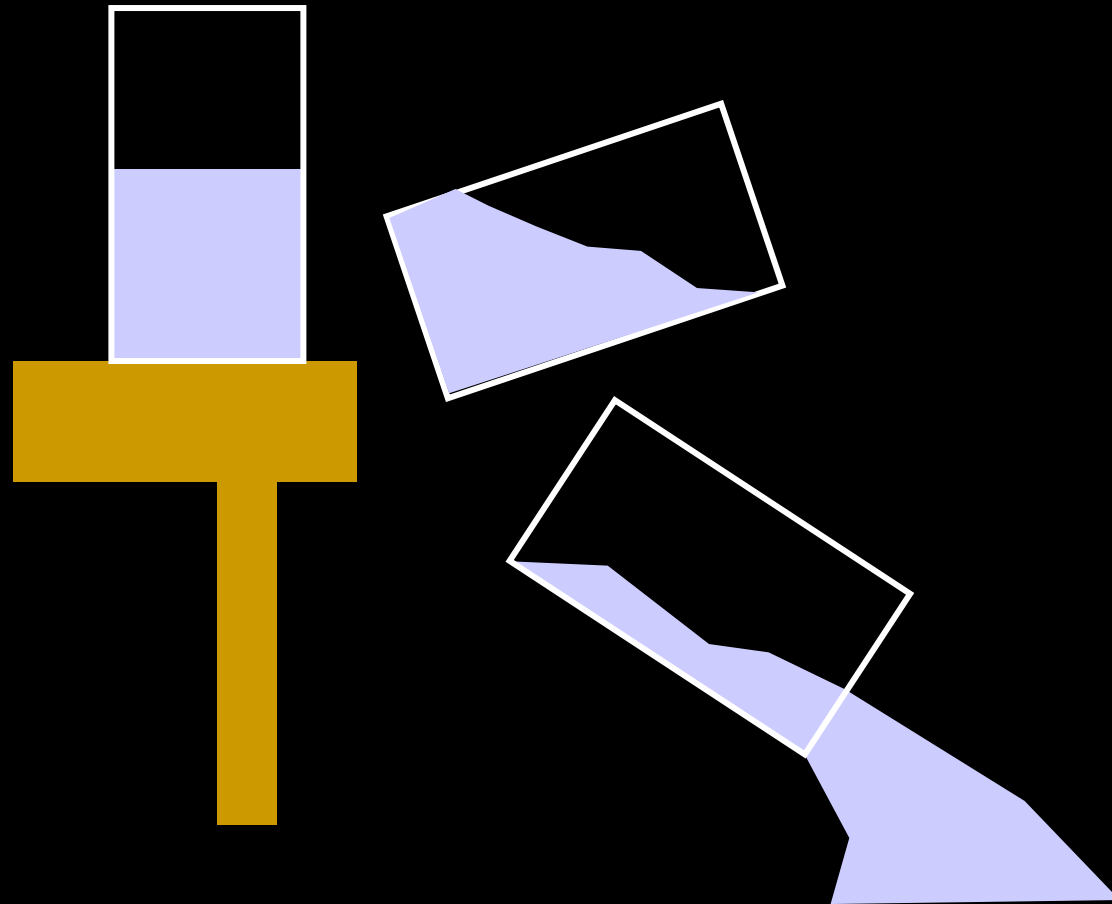

# Stable Equilibrium

- *energy added*
- *things don't change*

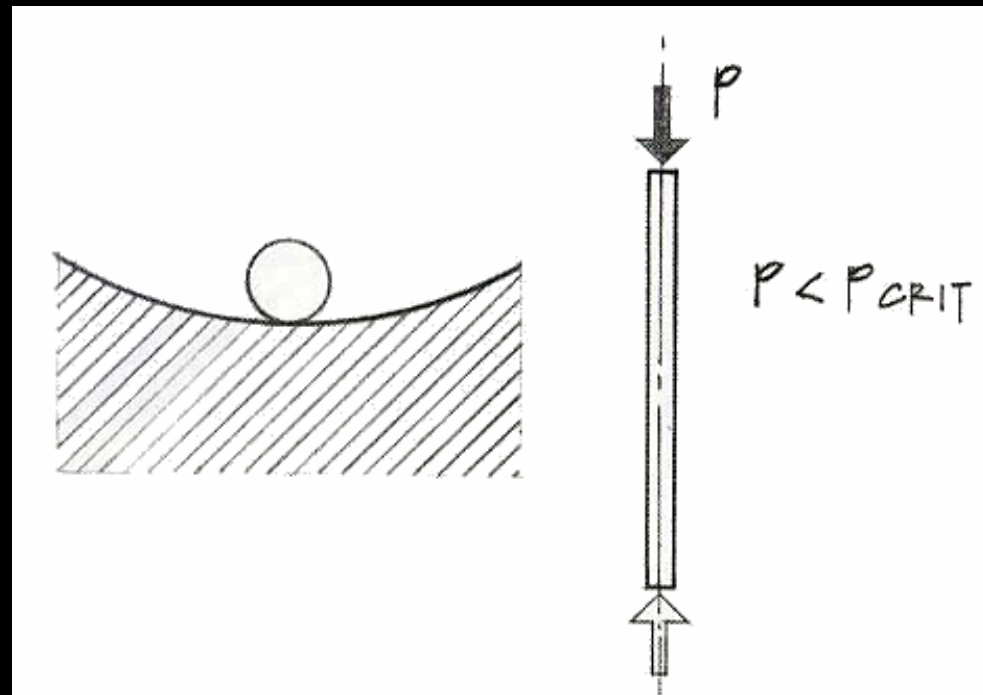

# Neutral Equilibrium

- *energy added*
- *things change, but not much*

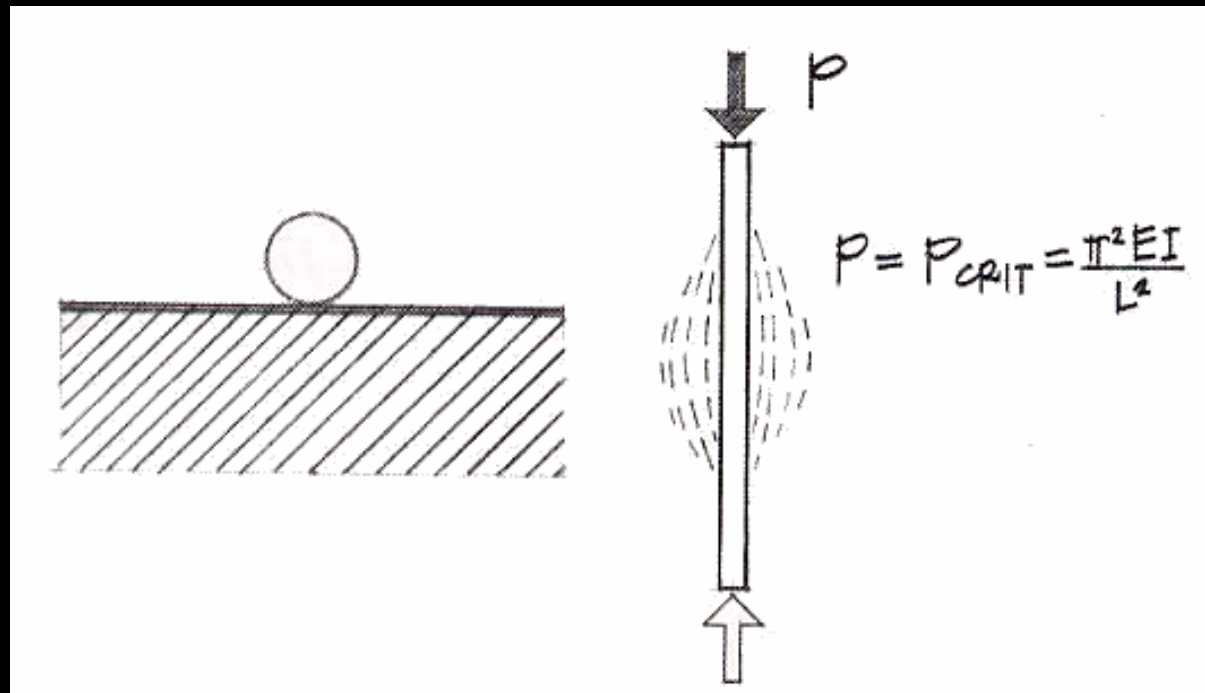

# Unstable Equilibrium

---

- *energy added*
- *things change drastically*

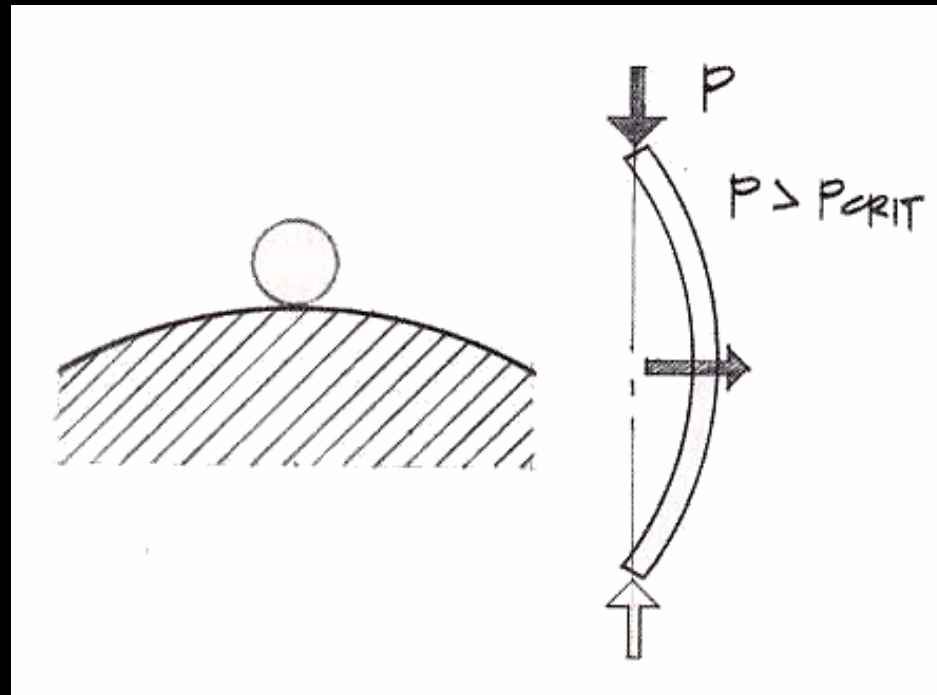

# Column Buckling

- axially loaded columns
- long & slender
  - unstable equilibrium = buckling
  - sudden and not good

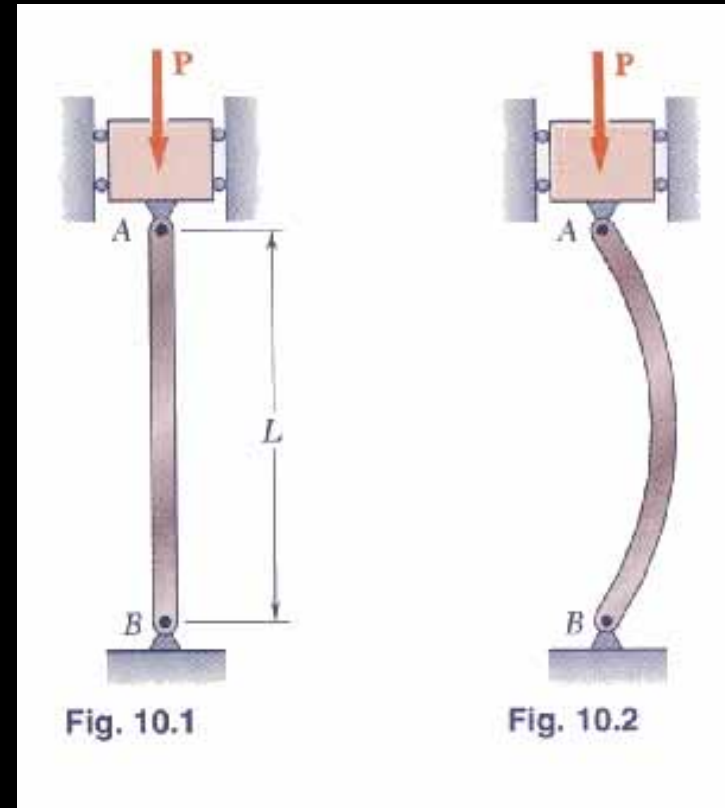

# Modeling

- can be modeled with a spring at mid-height
- when moment from deflection exceeds the spring capacity ... “boing”
- critical load  $P$

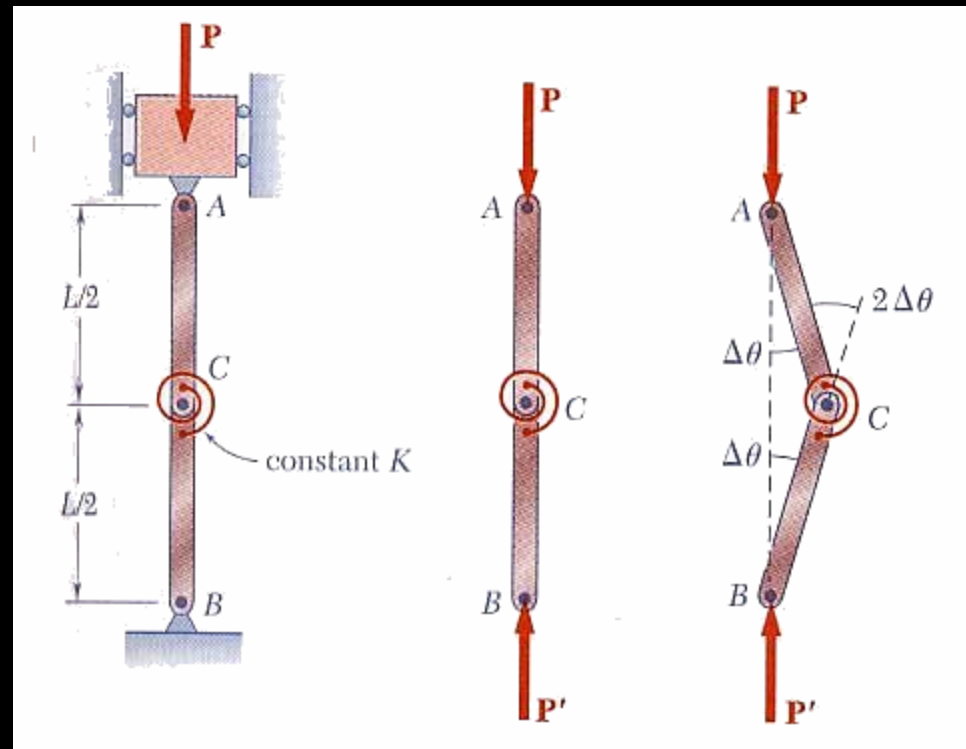



# Effect of Length

- long & slender

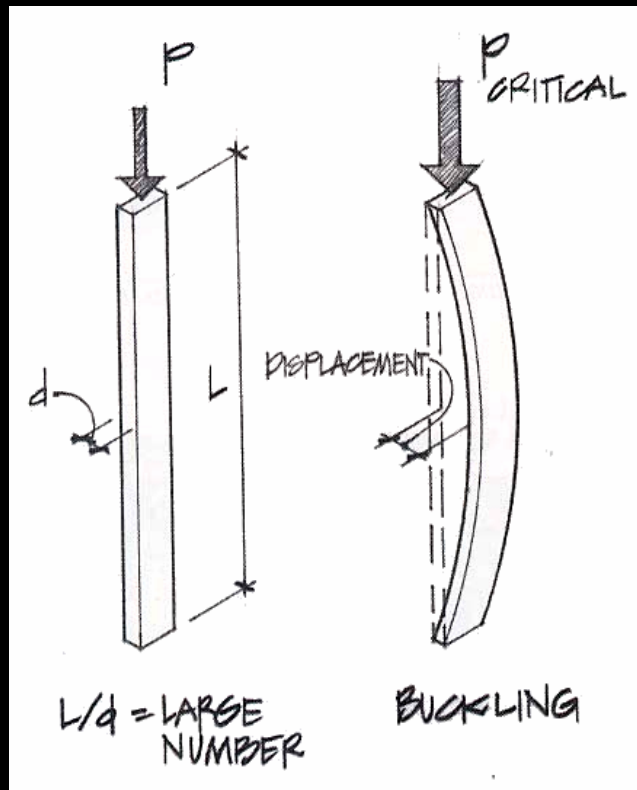

- short & stubby

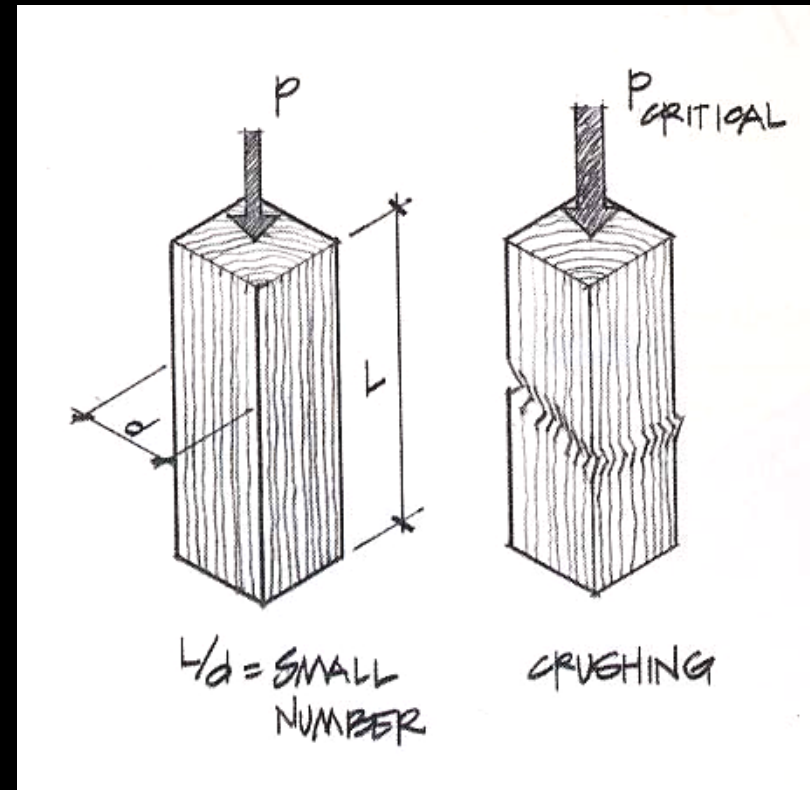

# Buckling Load

- related to deflected shape ( $P\Delta$ )
- shape of sine wave
- Euler's Formula
- $I$  minimum

$$P_{critical} = \frac{\pi^2 EI_{min}}{(L)^2}$$

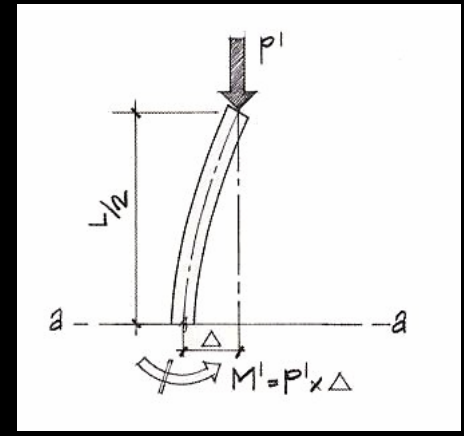

Figure 9.3 Leonhard Euler (1707–1783).

# Critical Stress

- short columns

$$f_{critical} = \frac{P_{actual}}{A} < F_a$$

- slenderness ratio =  $L_e/r$  ( $L/d$ )

- radius of gyration =  $r = \sqrt{\frac{I}{A}}$

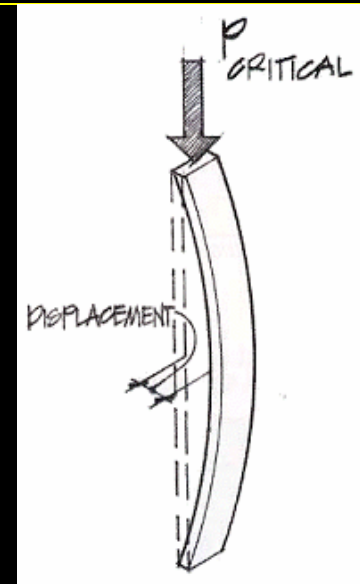

weak axis

$$f_{critical} = \frac{P_{critical}}{A} = \frac{\pi^2 E A r^2}{A (L_e)^2} = \frac{\pi^2 E}{\left(\frac{L_e}{r}\right)^2} \quad P_{critical} = \frac{\pi^2 E A}{\left(\frac{L_e}{r}\right)^2}$$

# Critical Stresses

- when a column gets stubby,  $F_y$  will limit the load
- real world has loads with eccentricity
- $C_c$  for steel and allowable stress

$$\frac{L_e}{r} > C_c = \sqrt{\frac{2\pi^2 E}{F_y}}$$

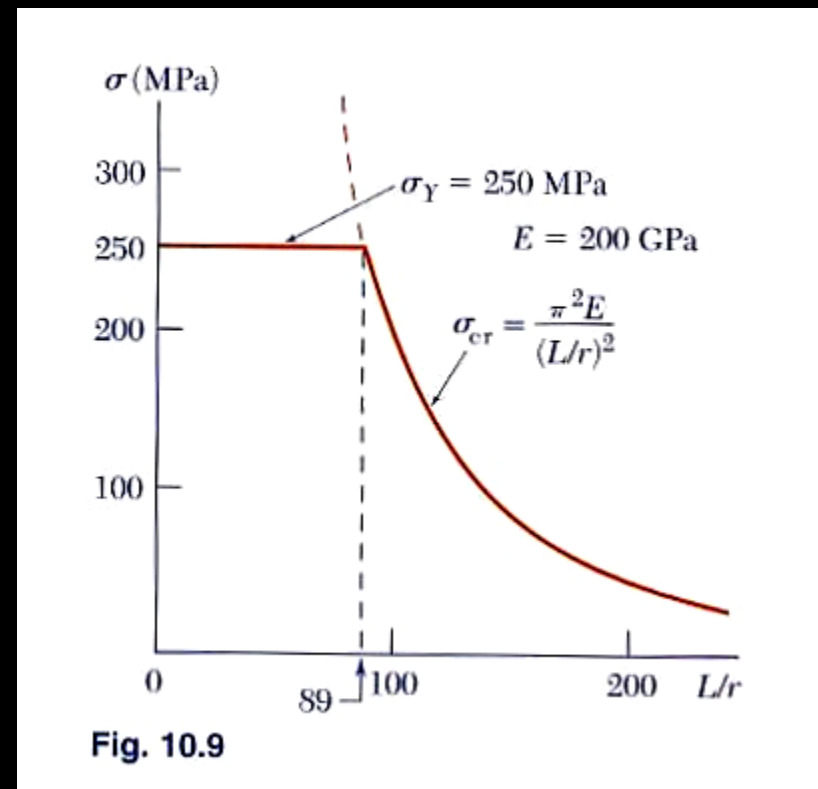

# Effective Length

- end conditions affect shape
- effective length factor,  $K$        $L_e = K \cdot L$

|  |      |      |     |     |      |     |
|--|------|------|-----|-----|------|-----|
| Buckled shape of column shown by dashed line                     | (a)  | (b)  | (c) | (d) | (e)  | (f) |
|  |      |      |     |     |      |     |
| Theoretical $K$ value  | 0.5  | 0.7  | 1.0 | 1.0 | 2.0  | 2.0 |
| Recommended design values when ideal conditions are approximated | 0.65 | 0.80 | 1.0 | 1.2 | 2.10 | 2.0 |

# Bracing

- *bracing affects shape of buckle in one direction*
- *both should be checked!*

