

*ARCHITECTURAL STRUCTURES I:
STATICS AND STRENGTH OF MATERIALS*

ENDS 231

DR. ANNE NICHOLS

SPRING 2008

*lecture
thirteen*



***beam forces –
internal***

Beams

- *span horizontally*
 - floors
 - bridges
 - roofs

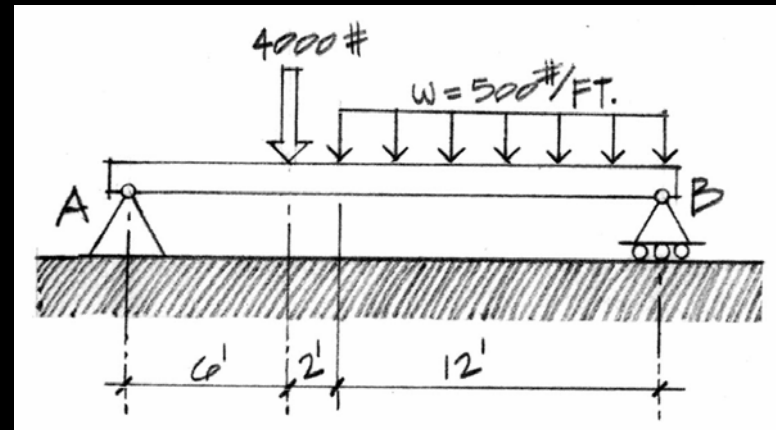

- *loaded transversely by gravity loads*
- *may have internal axial force*
- *will have* *internal shear force*
- *will have* *internal moment (bending)*

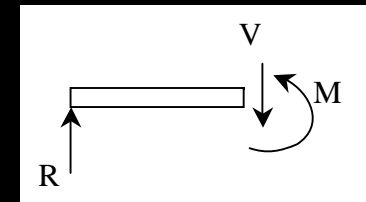

Internal Forces

- *trusses*
 - *axial only, (compression & tension)*

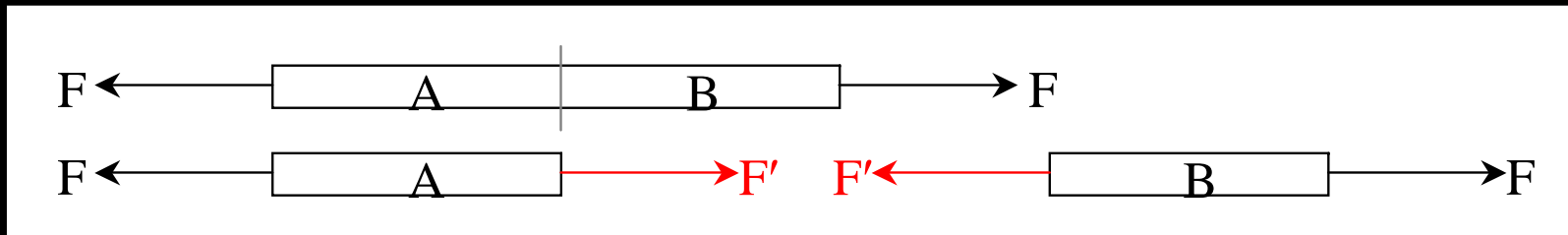

- *in general*
 - *axial force*
 - *shear force, V*
 - *bending moment, M*

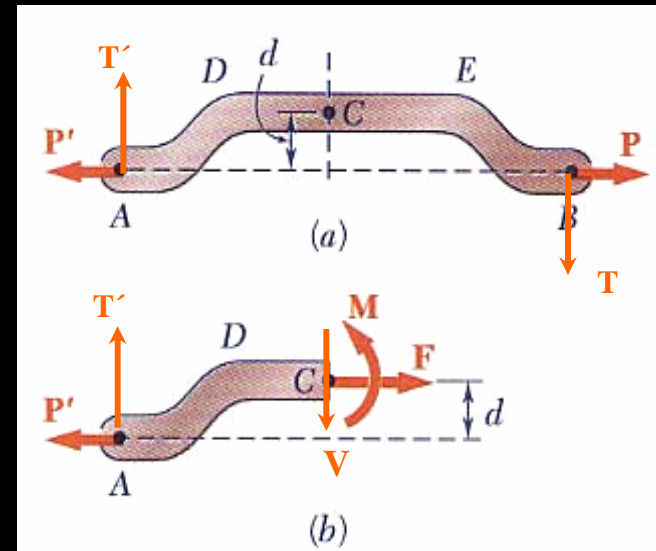

Beam Loading

- concentrated force
- concentrated moment
 - spandrel beams

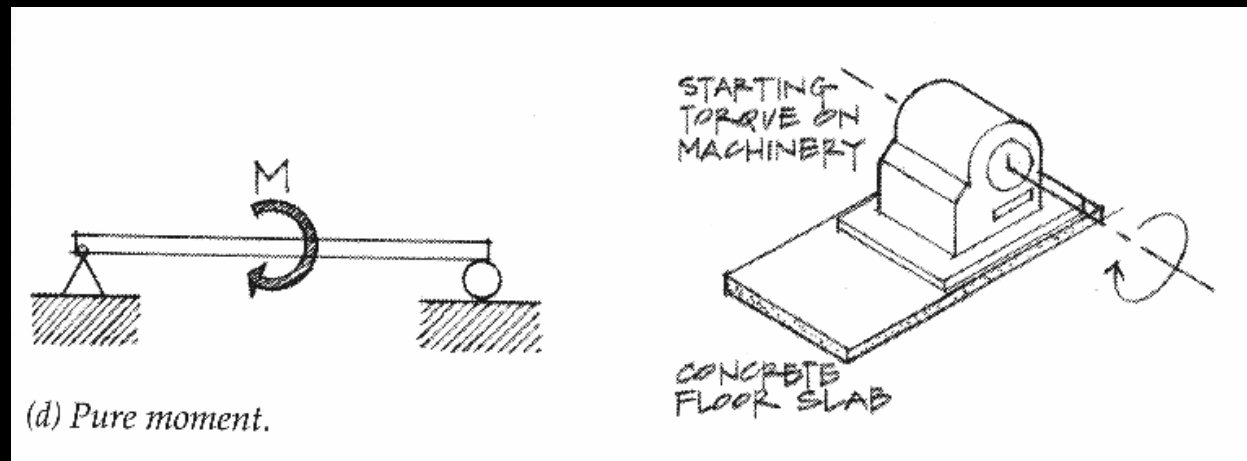
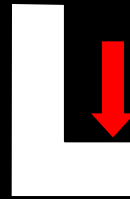

Beam Loading

- *uniformly distributed load (line load)*
- *non-uniformly distributed load*
 - *hydrostatic pressure*
 - *wind loads*

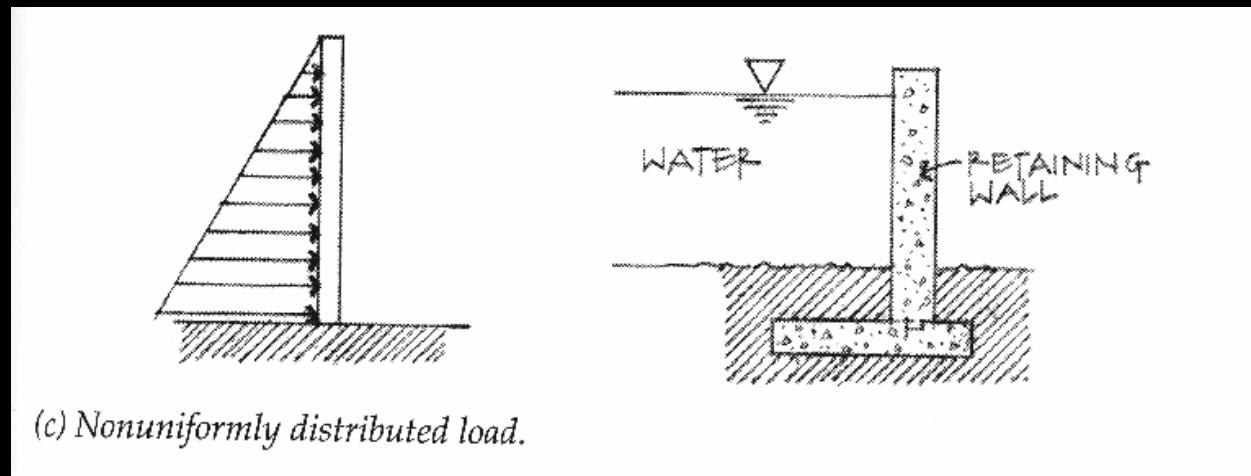

Beam Supports

- *statically determinate*

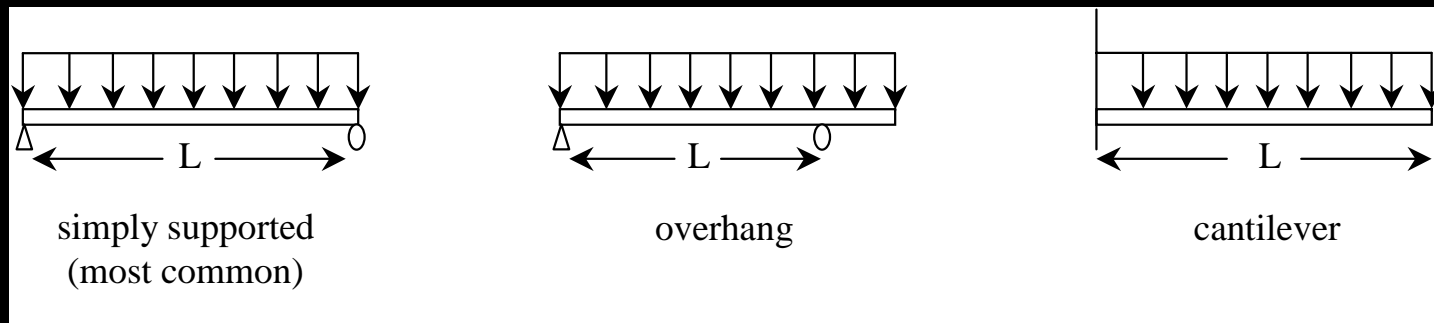

- *statically indeterminate*

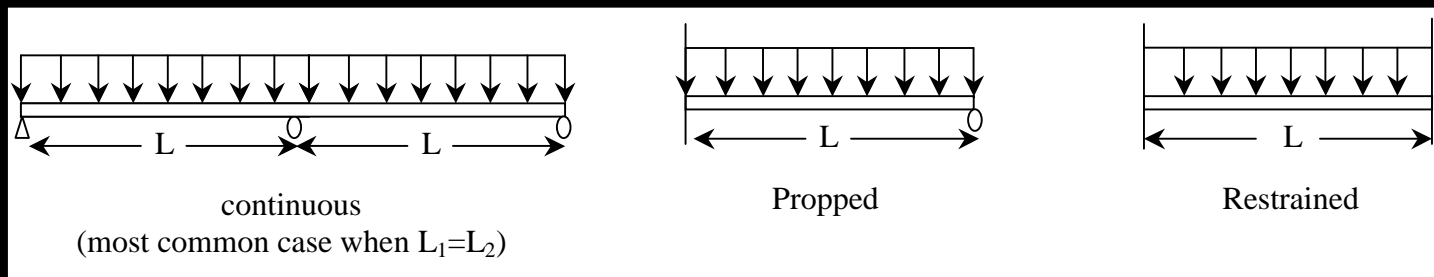

Beam Supports

- *in the real world, modeled type*

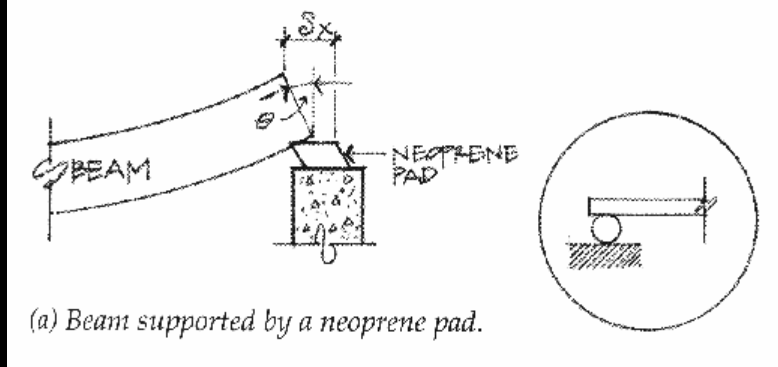
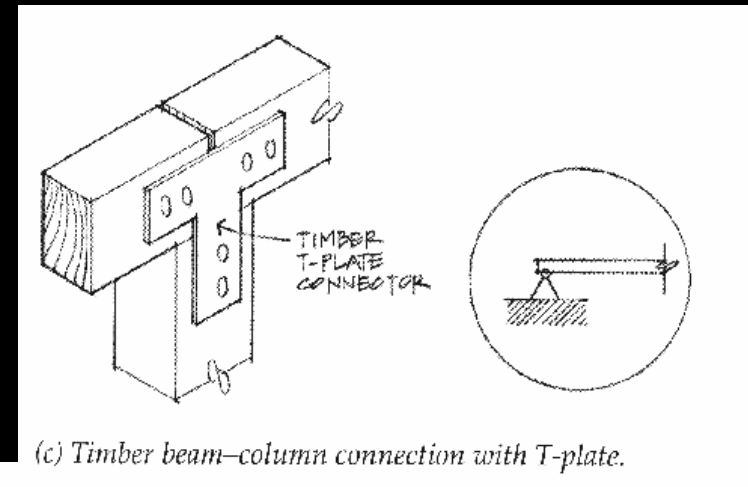
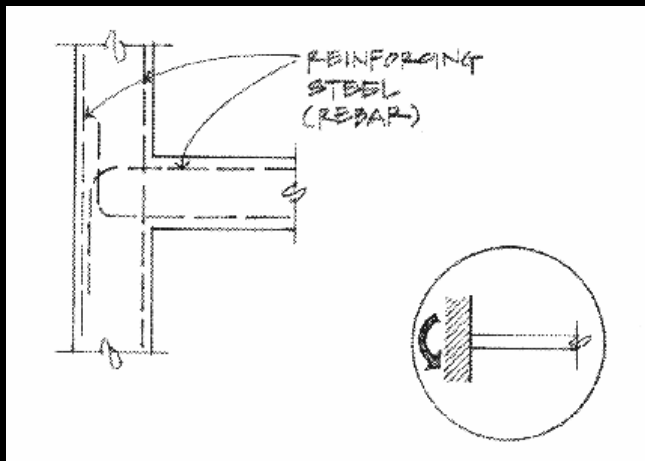

Internal Forces in Beams

- *like method of sections / joints*
 - *no axial forces*
- *section must be in equilibrium*
- *want to know where biggest internal forces and moments are for designing*

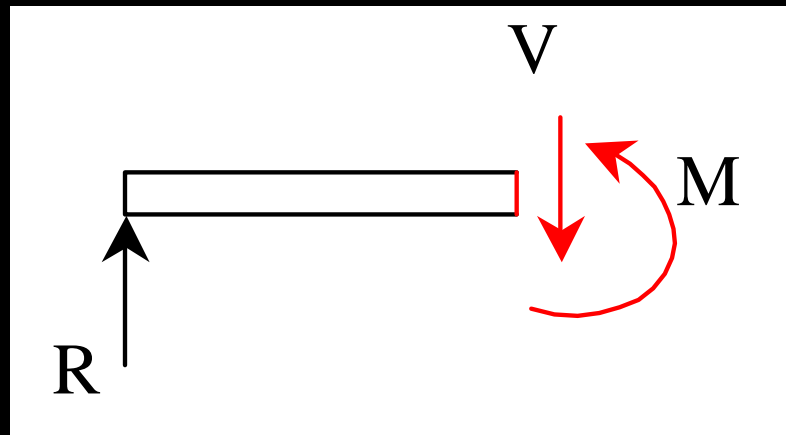

V & M Diagrams

- *tool to locate V_{max} and M_{max}*
- *necessary for designing*
- *have a different sign convention than external forces, moments, and reactions*

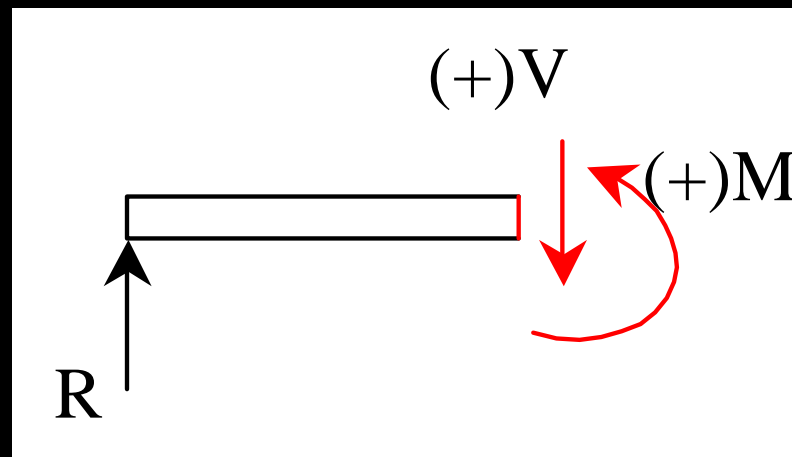

Sign Convention

- *shear force, V :*
 - *cut section to LEFT*
 - *if $\sum F_y$ is positive by statics, V acts down and is POSITIVE*
 - *beam has to resist shearing apart by V*

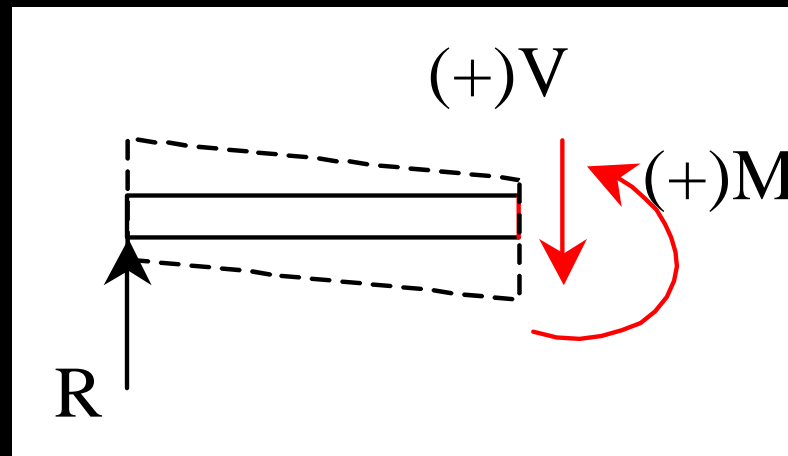

Shear Sign Convention

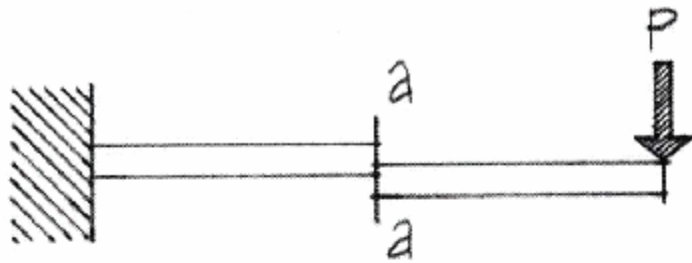

(+) Shear.

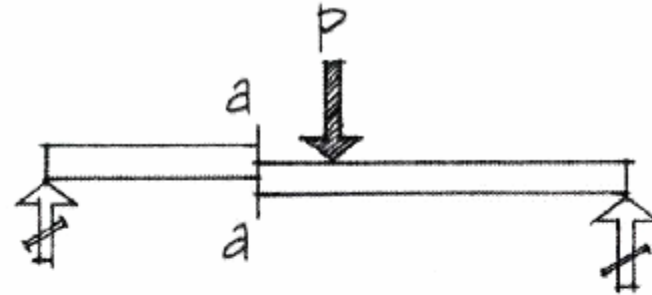

(+) Shear.

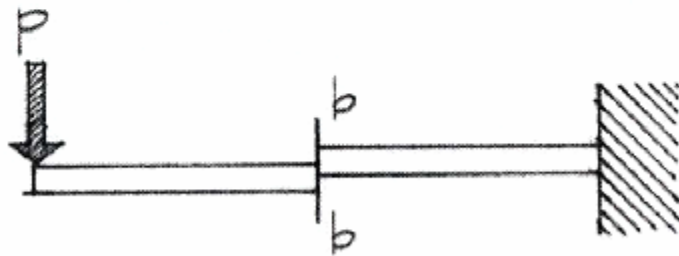

(-) Shear.

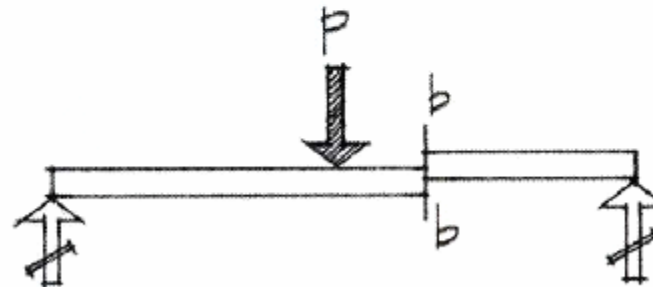

(-) Shear.

Sign Convention

- *bending moment, M :*
 - *cut section to LEFT*
 - *if $\sum M_{cut}$ is clockwise, M acts ccw and is **POSITIVE** – flexes into a “smiley” beam
has to resist bending apart by M*

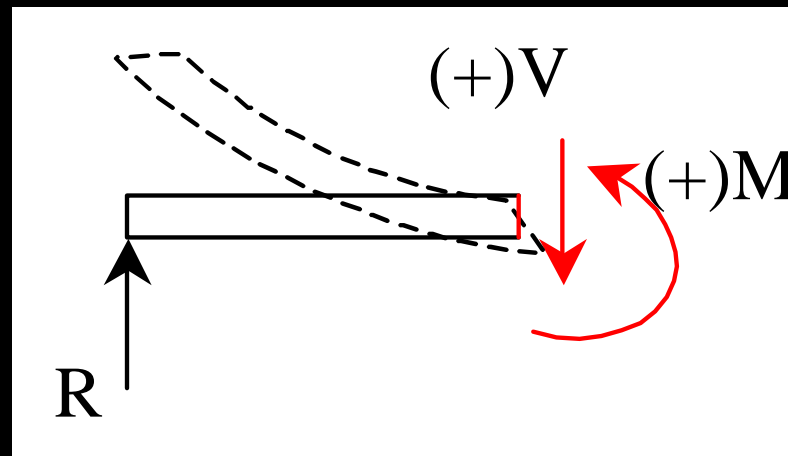

Bending Moment Sign Convention

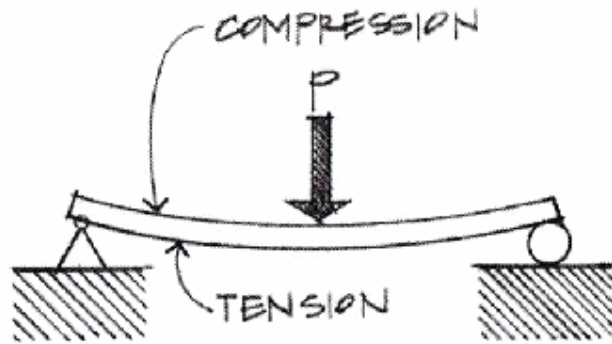

(+) Moment.

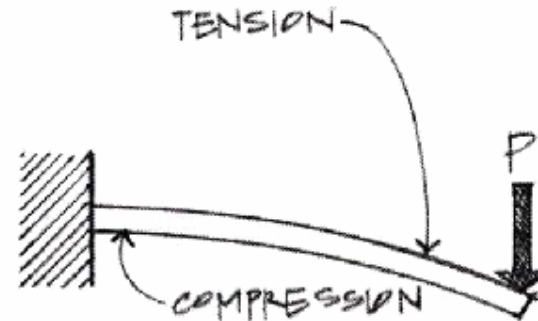

(-) Moment.



(+) Moment.

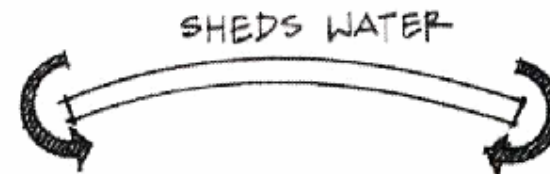

(-) Moment.

Deflected Shape

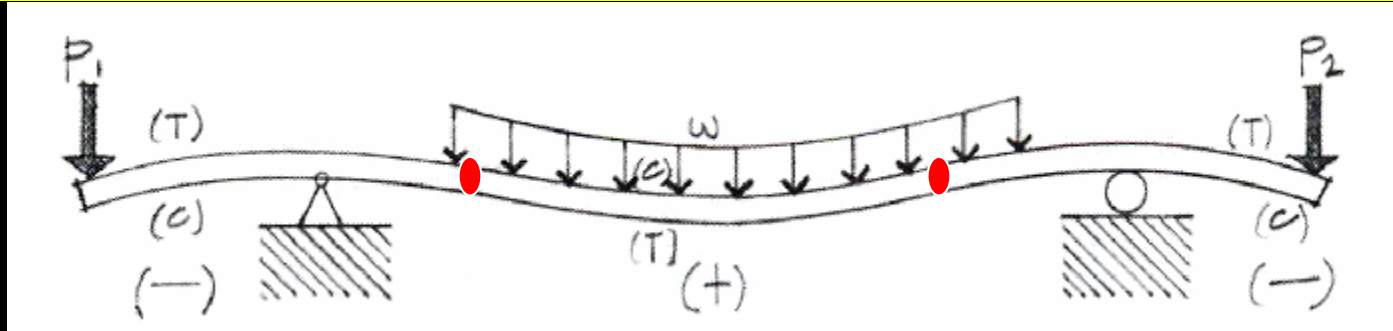

- **positive bending moment**
 - tension in bottom, compression in top
- **negative bending moment**
 - tension in top, compression in bottom
- **zero bending moment**
 - inflection point

Constructing V & M Diagrams

- along the beam length, plot V, plot M

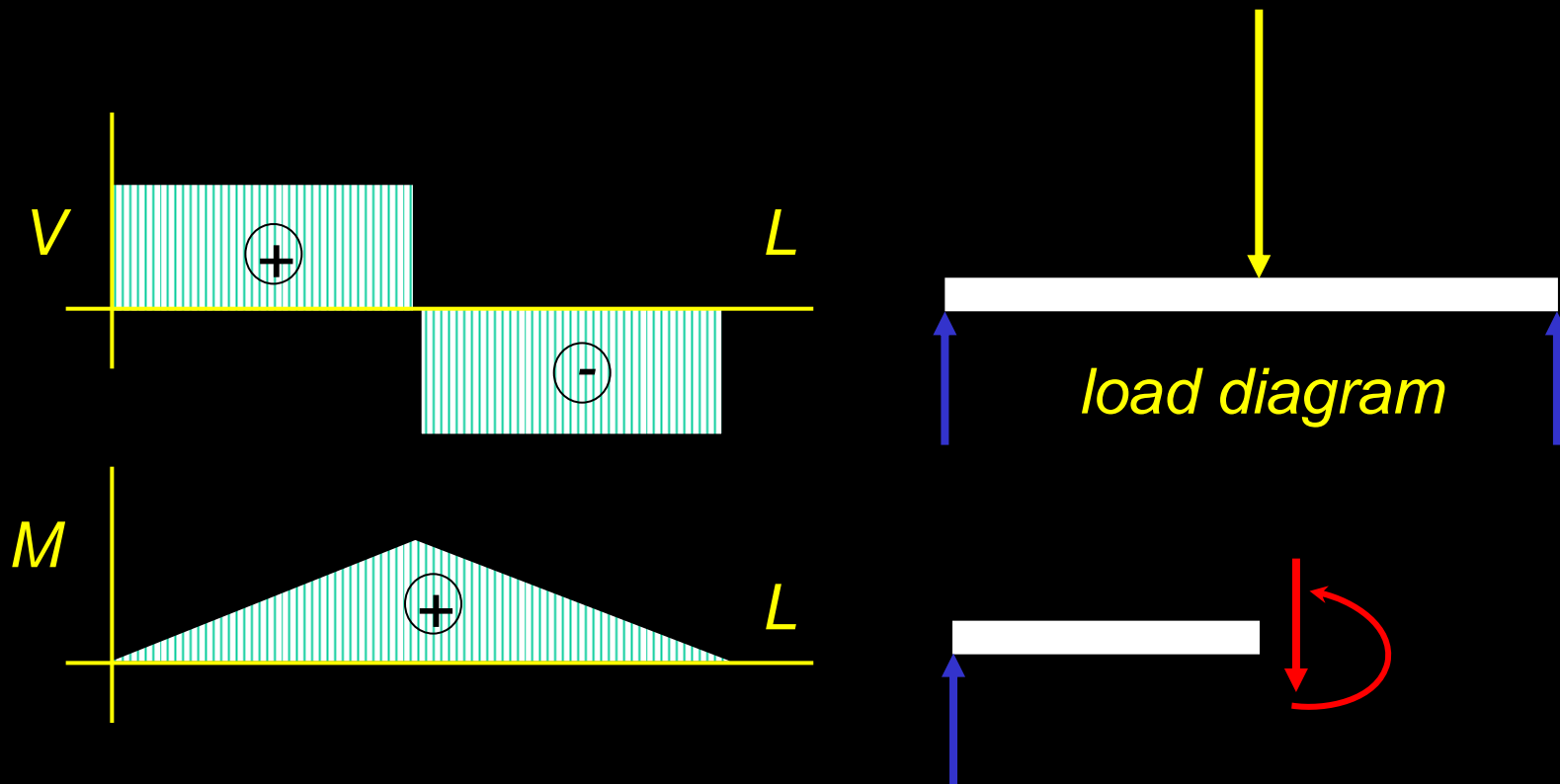

Mathematical Method

- cut sections with x as width
- write functions of $V(x)$ and $M(x)$

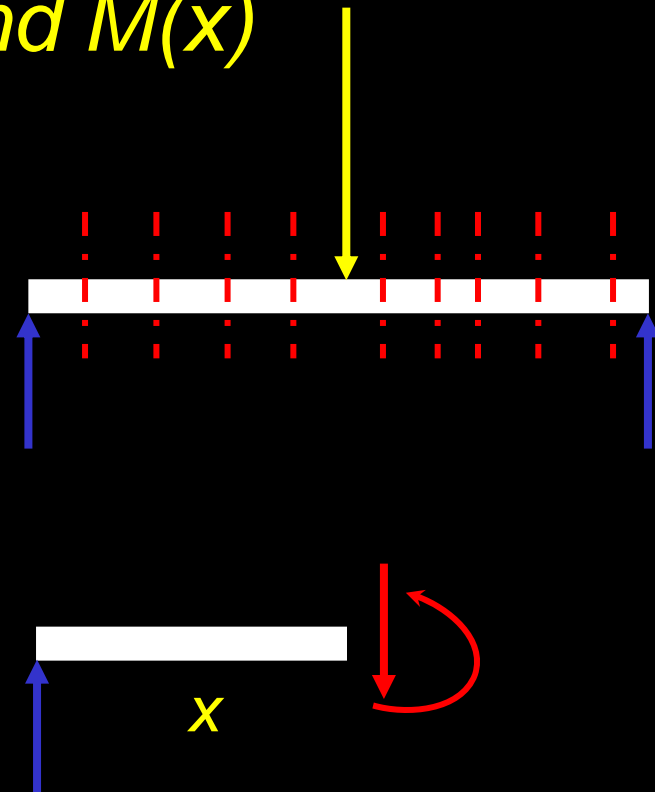
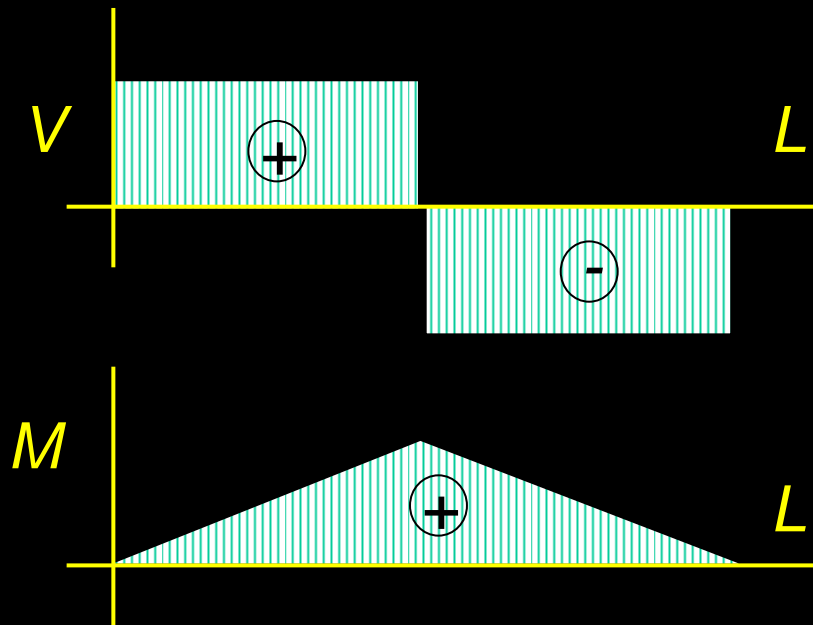

Method 1: Equilibrium

- cut sections at important places
- plot V & M

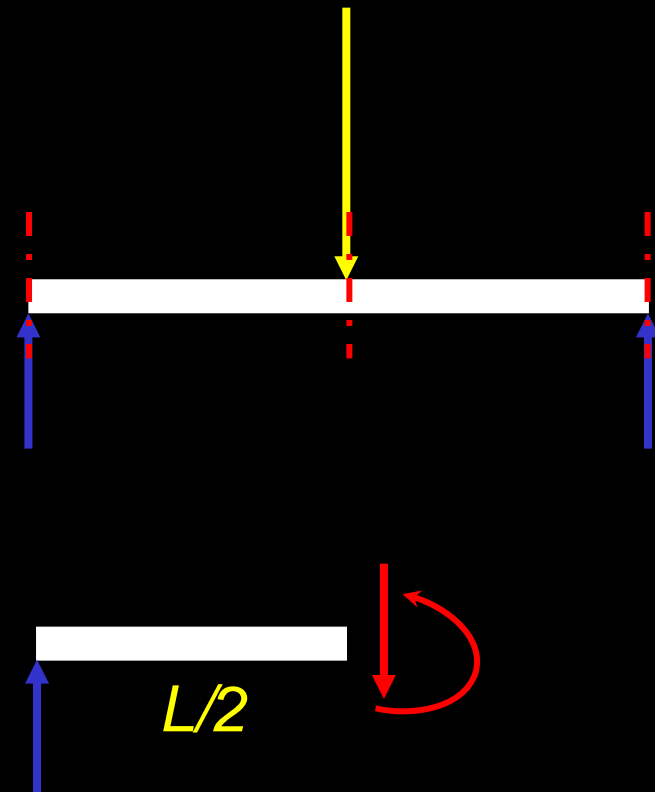
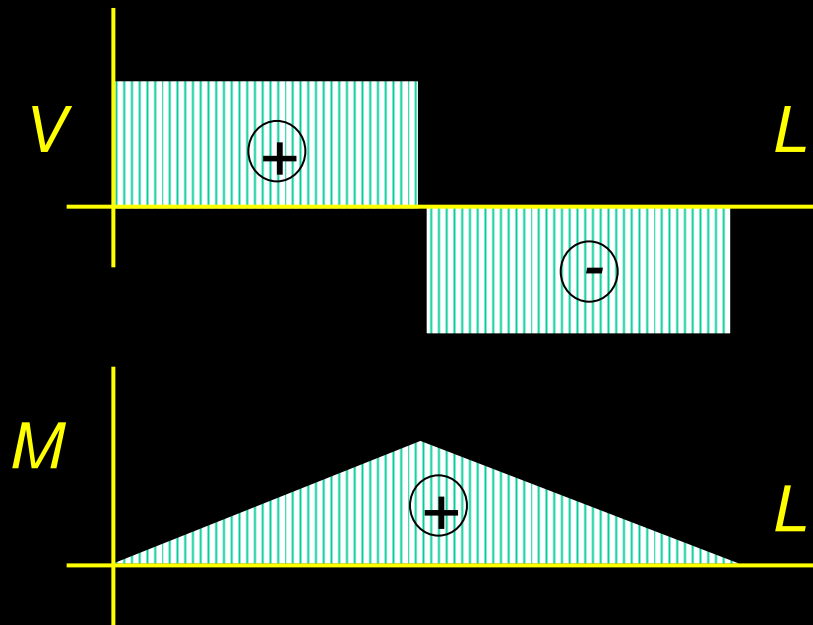

Method 1: Equilibrium

- *important places*
 - *supports*
 - *concentrated loads*
 - *start and end of distributed loads*
 - *concentrated moments*
- *free ends*
 - *zero forces*

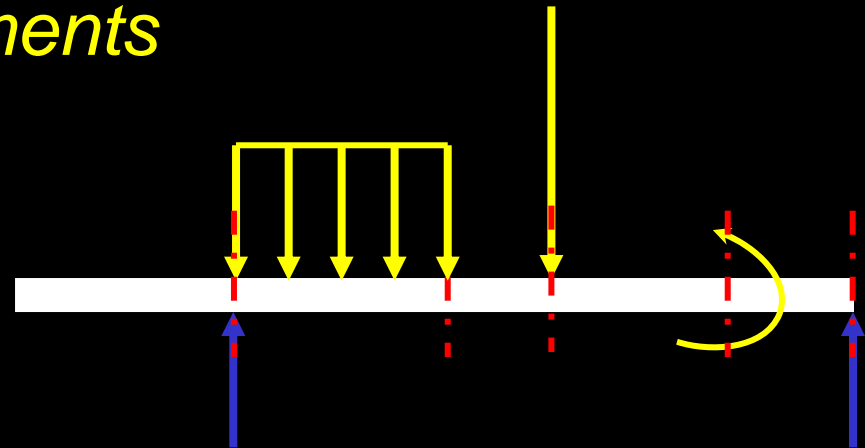

Method 2: Semigraphical

- *by knowing*
 - *area under loading curve = change in V*
 - *area under shear curve = change in M*
 - *concentrated forces cause “jump” in V*
 - *concentrated moments cause “jump” in M*

$$V_D - V_C = - \int_{x_C}^{x_D} w dx \quad M_D - M_C = \int_{x_C}^{x_D} V dx$$

Method 2

- relationships

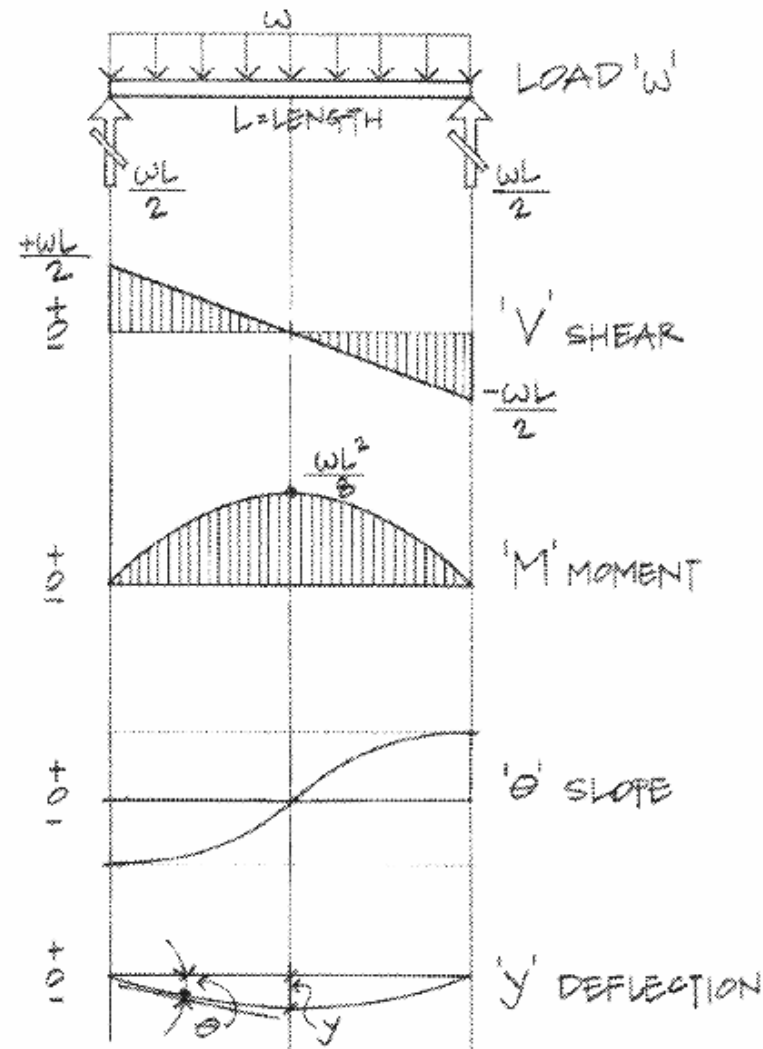
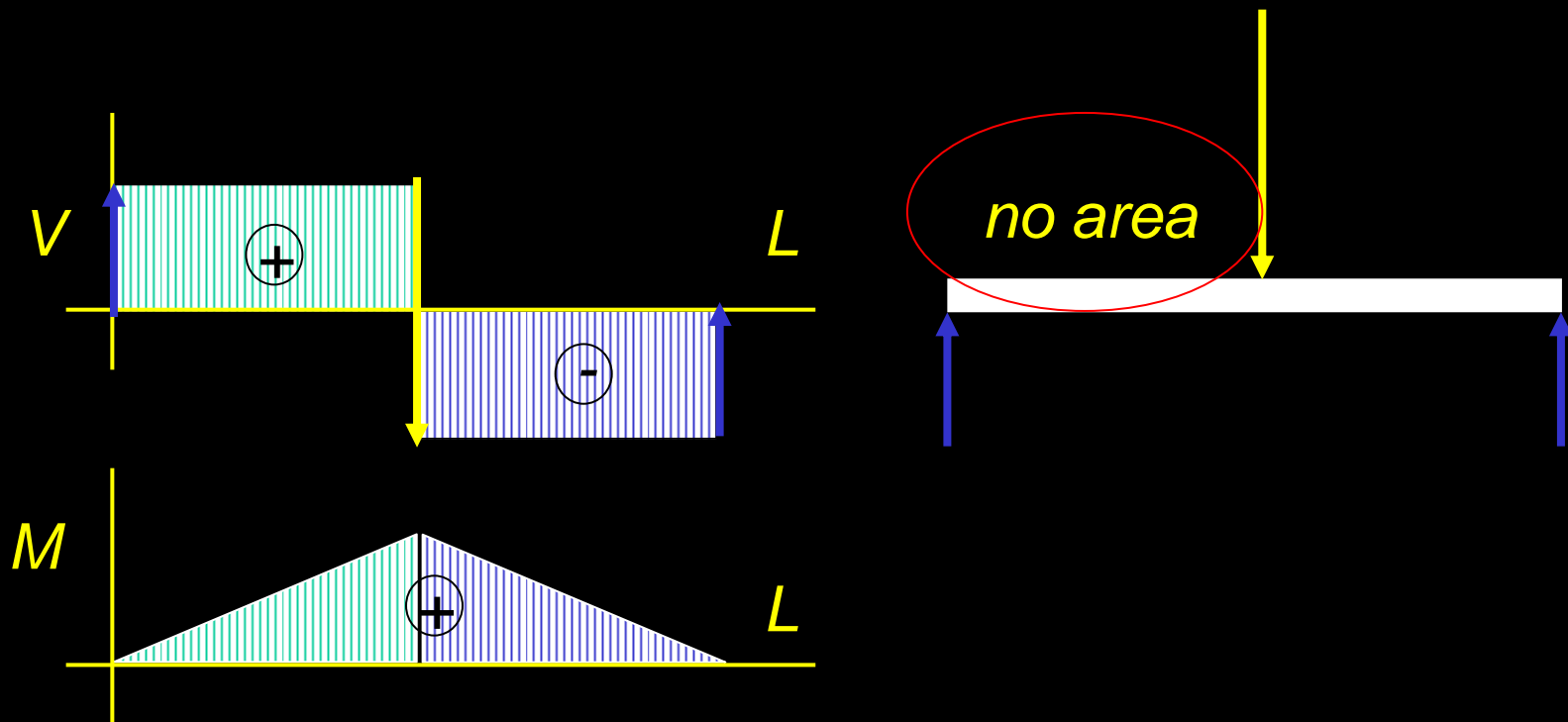

Figure 7.11 Relationship of load, shear, moment, slope, and deflection diagrams.

Method 2: Semigraphical

- M_{max} occurs where $V = 0$ (calculus)



Curve Relationships

- *integration of functions*
- *line with 0 slope, integrates to sloped*

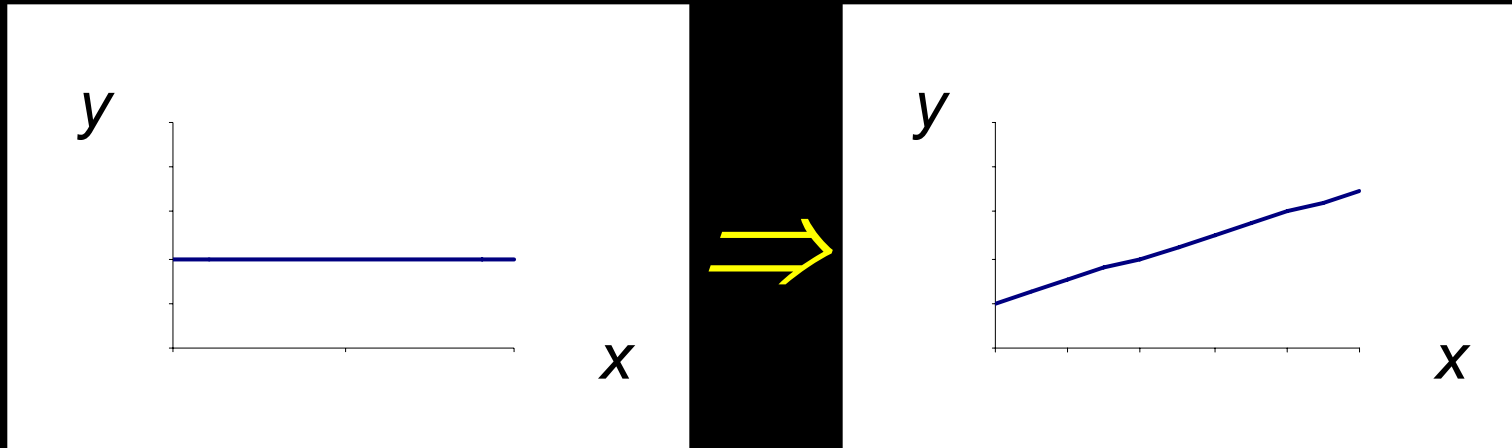

- *ex: load to shear, shear to moment*

Curve Relationships

- *line with slope, integrates to parabola*

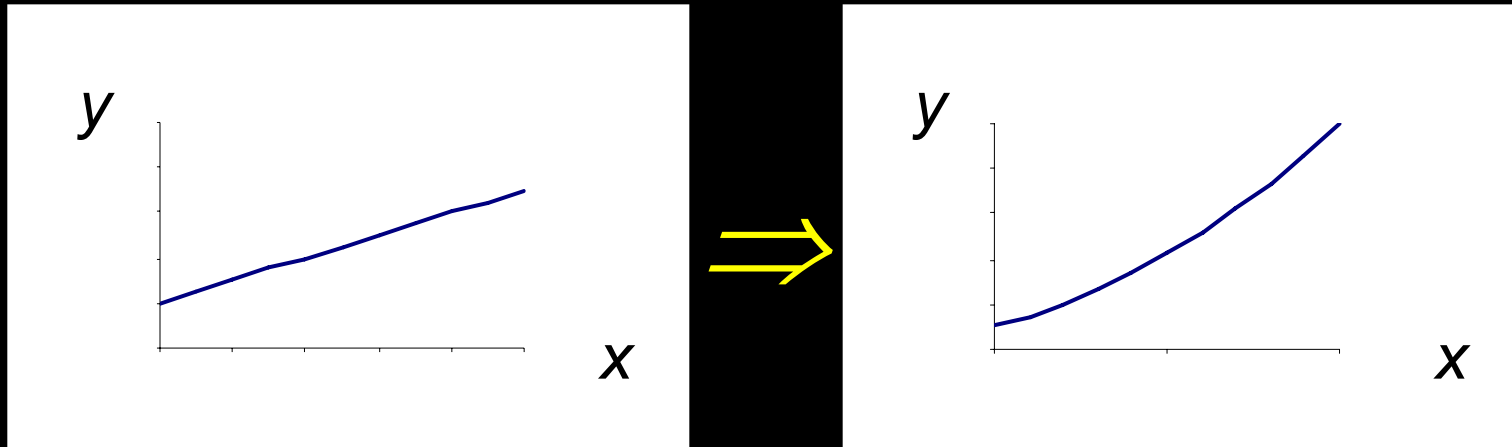

- *ex: load to shear, shear to moment*

Curve Relationships

- *parabola, integrates to 3rd order curve*

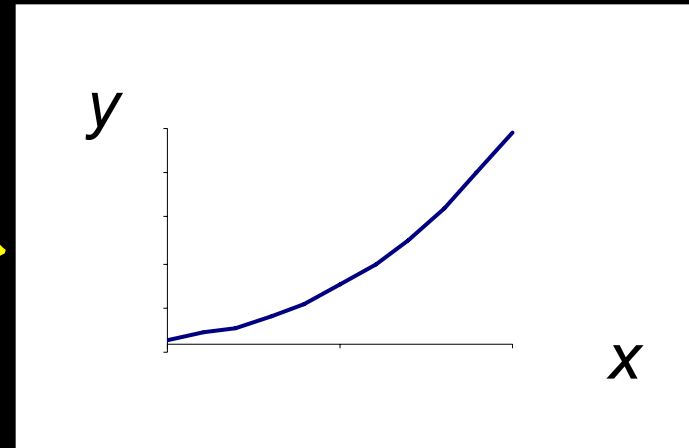
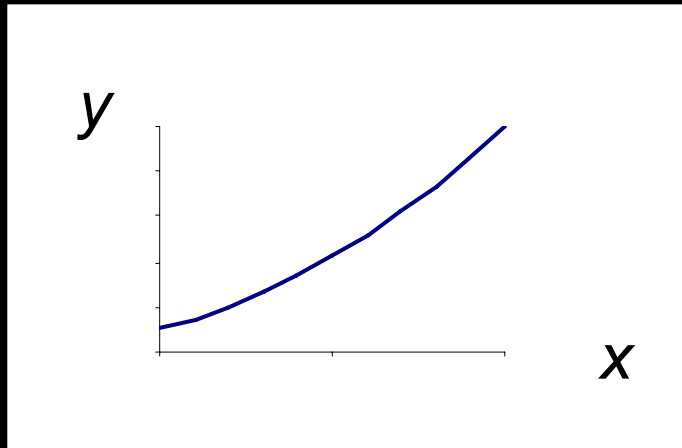

- *ex: load to shear, shear to moment*

Basic Procedure

- 1. Find reaction forces & moments
Plot axes, underneath beam load diagram*

V:

- 2. Starting at left*
- 3. Shear is 0 at free ends*
- 4. Shear jumps with concentrated load*
- 5. Shear changes with area under load*

Basic Procedure

M:

6. Starting at left

7. Moment is 0 at free ends

8. Moment jumps with moment

9. Moment changes with area under V

Triangle Geometry

- slope of V is w ($-w:1$)

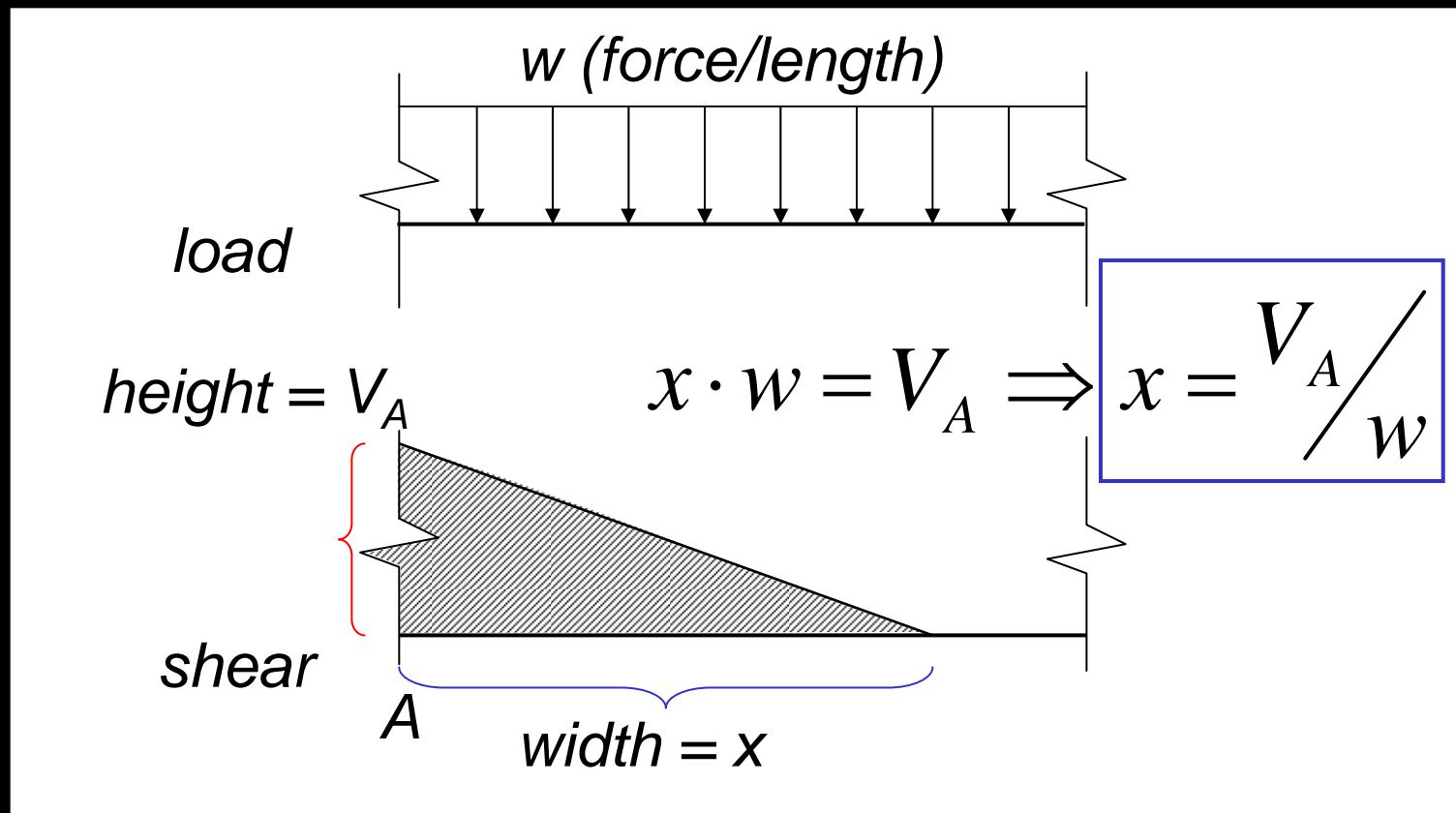

Parabolic Shapes

- cases

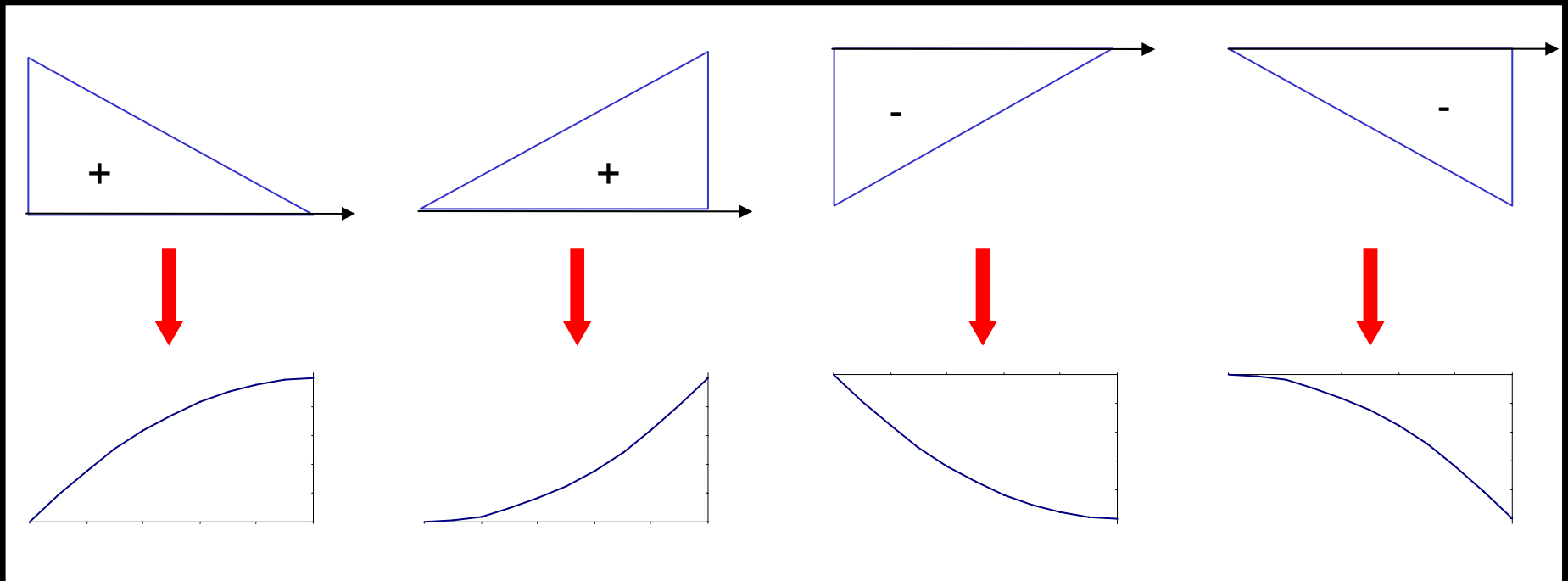

*up fast,
then slow*

*up slow,
then fast*

*down fast,
then slow*

*down slow,
then fast*