

ARCHITECTURAL STRUCTURES I:
STATICS AND STRENGTH OF MATERIALS
ENDS 231

DR. ANNE NICHOLS
SPRING 2008

lecture
one

***statics and strength
of materials***

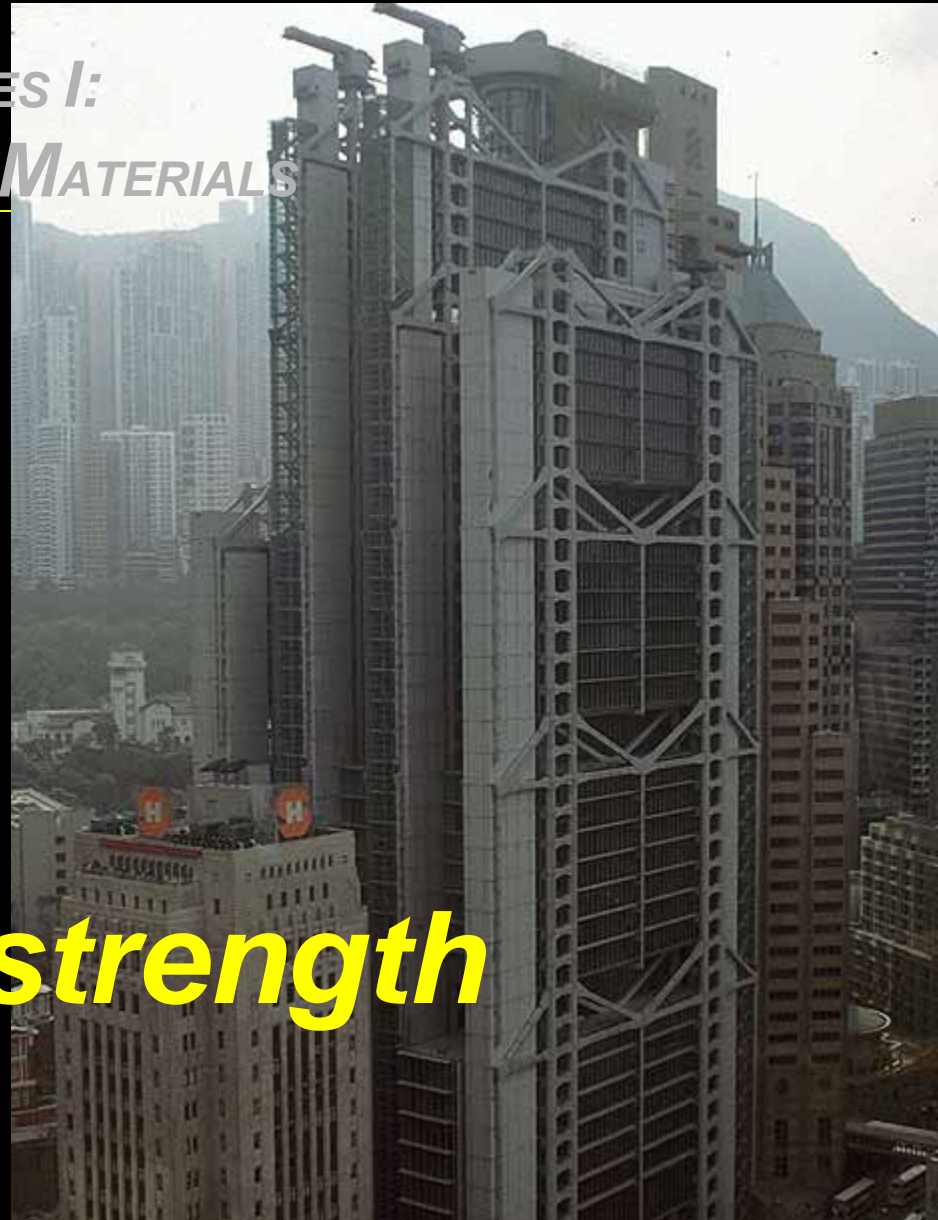

Syllabus & Student Understandings

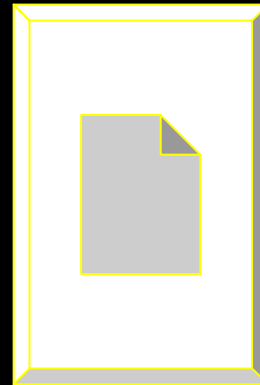
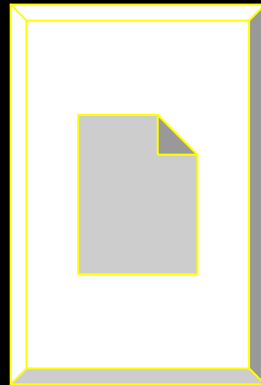

Course Description

- *statics*
 - *physics of forces and reactions on bodies and systems*
 - *equilibrium (bodies at rest)*
- *structures*
 - *something made up of interdependent parts in a definite pattern of organization*

Course Description

- *mechanics of materials*
 - *external loads and effect on deformable bodies*
 - *use it to answer question if structure meets requirements of*
 - *stability and equilibrium*
 - *strength and stiffness*
 - *other principle building requirements*
 - *economy, functionality and aesthetics*

Structure Requirements

- *stability & equilibrium*
– *STATICS*



Figure 1.16 Equilibrium and Stability?—sculpture by Richard Byer. Photo by author.

Structure Requirements (cont)

- *strength & stiffness*
 - *concerned with stability of components*



Figure 1.15 Stability and the strength of a structure—the collapse of a portion of the UW Husky stadium during construction (1987) due to a lack of adequate bracing to ensure stability. Photo by author.

Structural System Selection

- *kind & size of loads*
- *building function*
- *soil & topology of site*
- *systems integration*
- *fire rating*
- *construction (\$\$, schedule)*
- *architectural form*

Knowledge Required

- *external forces*
- *internal forces*
- *material properties*
- *member cross sections*
- *ability of a material to resist breaking*
- *structural elements that resist excessive*
 - *deflection*
 - *deformation*

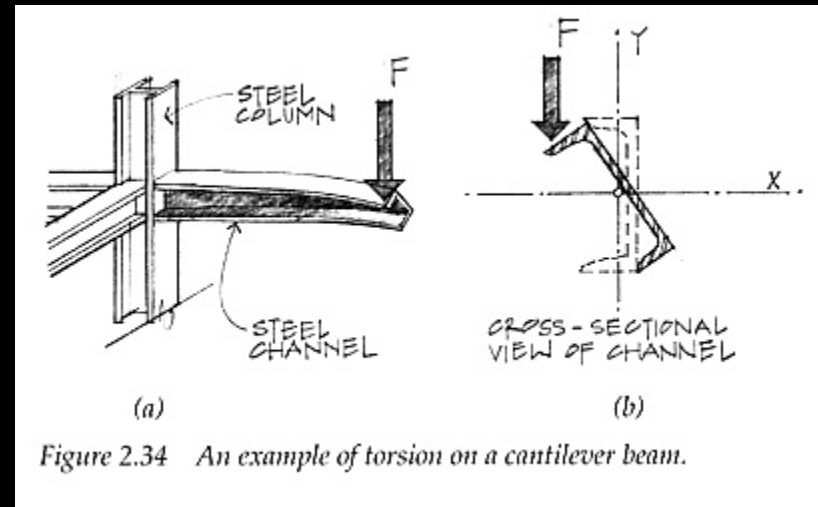

Problem Solving

1. STATICS:

*equilibrium of external forces,
internal forces, stresses*

2. GEOMETRY:

*cross section properties, deformations and
conditions of geometric fit, strains*

3. MATERIAL PROPERTIES:

*stress-strain relationship for each material
obtained from testing*



Relation to Architecture

“The geometry and arrangement of the load-bearing members, the use of materials, and the crafting of joints all represent opportunities for buildings to express themselves. The best buildings are not designed by architects who after resolving the formal and spatial issues, simply ask the structural engineer to make sure it doesn’t fall down.” - Onouye & Kane

*Statics and Strength of Materials for
Architecture and Building Construction*

Architectural Structures

- *incorporates*
 - *stability and equilibrium*
 - *strength and stiffness*
 - *economy, functionality and aesthetics*
- *USES*
 - *sculpture*
 - *furniture*
 - *buildings*

Architectural Space and Form

- *evolution traced to developments in structural engineering and material technology*
 - *stone & masonry*
 - *timber*
 - *concrete*
 - *cast iron, steel*
 - *tensile fabrics, pneumatic structures.....*

The “Fist”

Detroit, MI



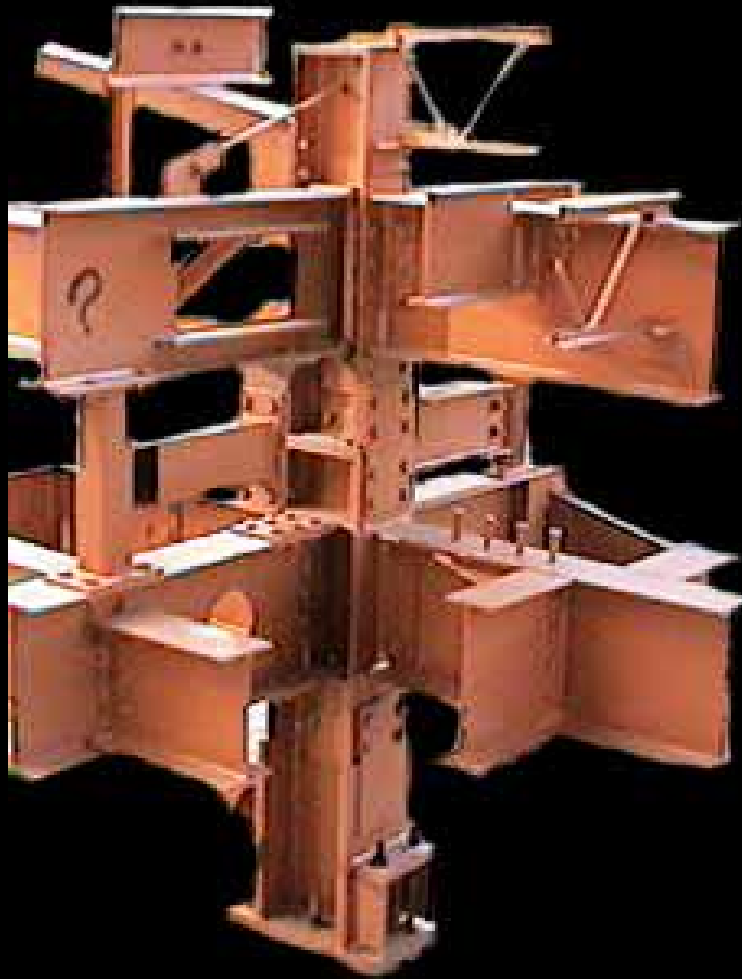

*AISC (Steel)
Sculpture
College Station, TX*



***“Jamborie”
Philadelphia, PA
Daniel Barret***

Exploris Mobile *Heath Satow*



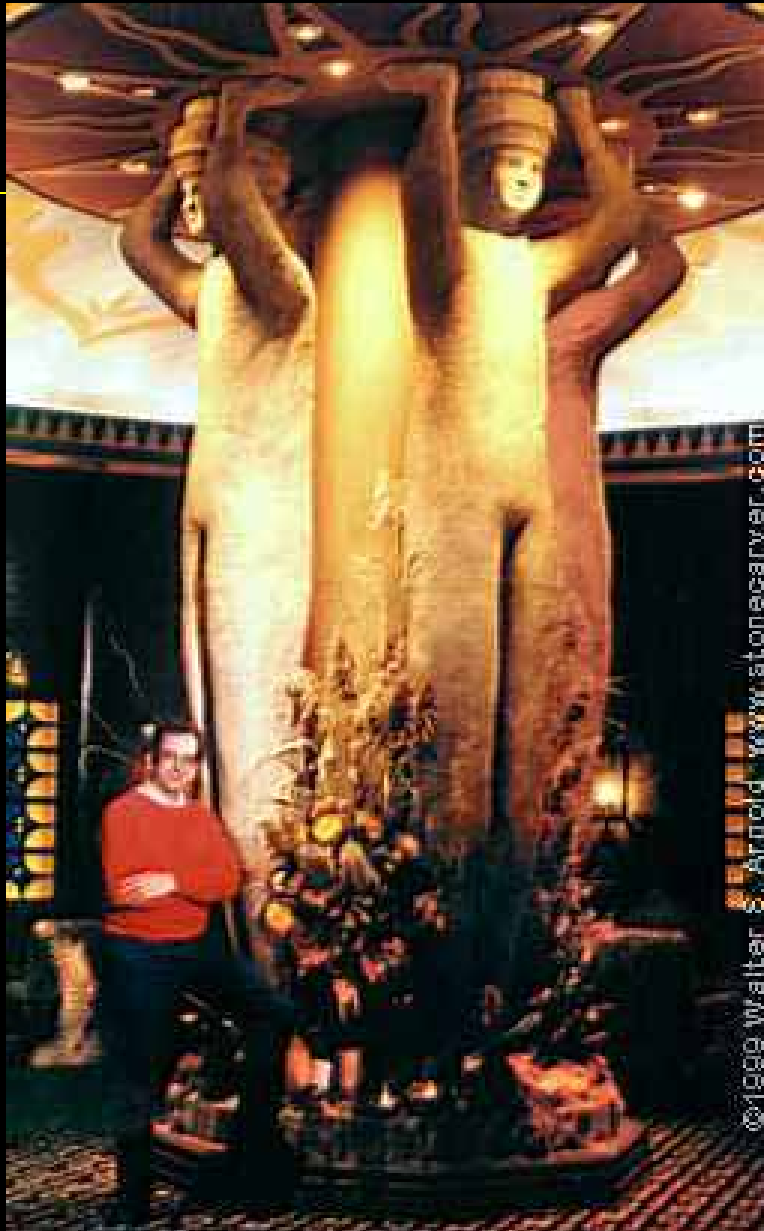

***“Telamones”
Chicago, IL
Walter Arnold***

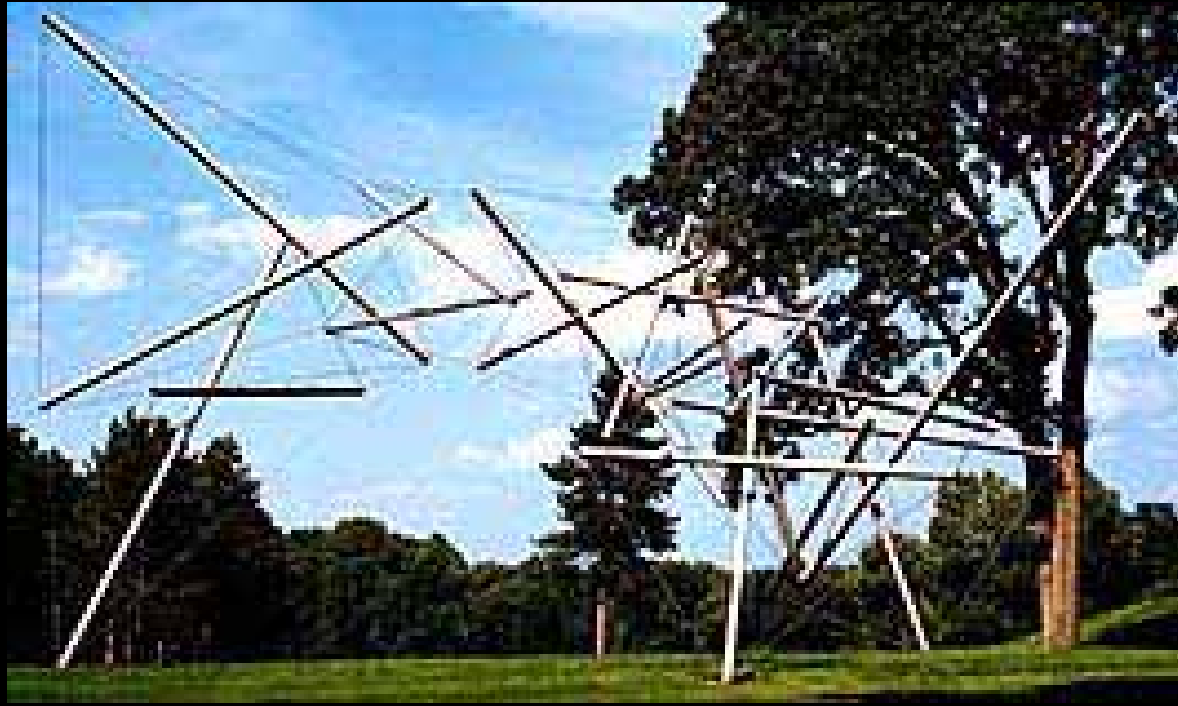

“Free Ride Home” 1974
Kenneth Snelson

“Zauber”
Laudenslager, Jeffery





*Conference
Table
Heath Satow*

Bar Stool
“Stainless Butterfly”
Daniel Barret





Chair
Paul Freundt

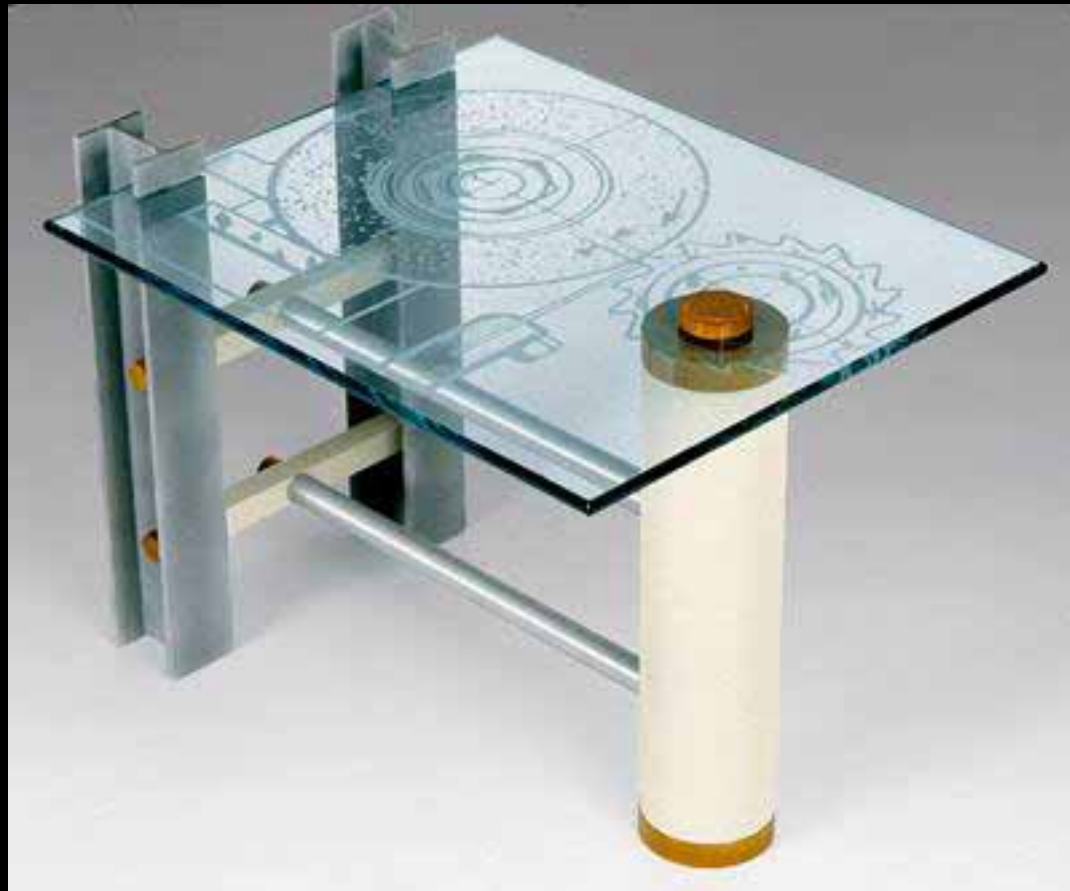

End Tables Rameu-Richard



Steel House, Lubbock, TX

Robert Bruno



Guggenheim Museum Bilbao *Frank Gehry (1997)*

*Tjibaou Cultural Center,
New Caledonia
Renzo Piano*



Photographer: John Gollings



Padre Pio Pilgrimage Church, Italy

Renzo Piano

Photographer: Michel Denancé

Introduction 27
Lecture 1

Architectural Structures I
ENDS 231

S2008abn



*Athens Olympic Stadium
and Velodrome
Santiago Calatrava (2004)*



*Milwaukee Art Museum
Quadracci Pavilion (2001)
Santiago Calatrava*





Airport Station, Lyon, France *Santiago Calatrava (1994)*



Centre Georges Pompidou, Paris *Piano and Rogers (1978)*



*Hongkong Bank
Building (1986)
Foster and Partners*

*Introduction 32
Lecture 1*

*Architecture
ENDS 231*



Meyerson Symphony Center
Dallas, TX
Pei Cobb Freed & Partners





Crystal Cathedral, LA
Philip Johnson (1980)

*Federal Reserve Bank
Minneapolis, MN
Gunnar Birkerts & Associates*





*Hysolar Research Building
Stuttgart, Germany (1986 -87)
Gunter Behnisch*

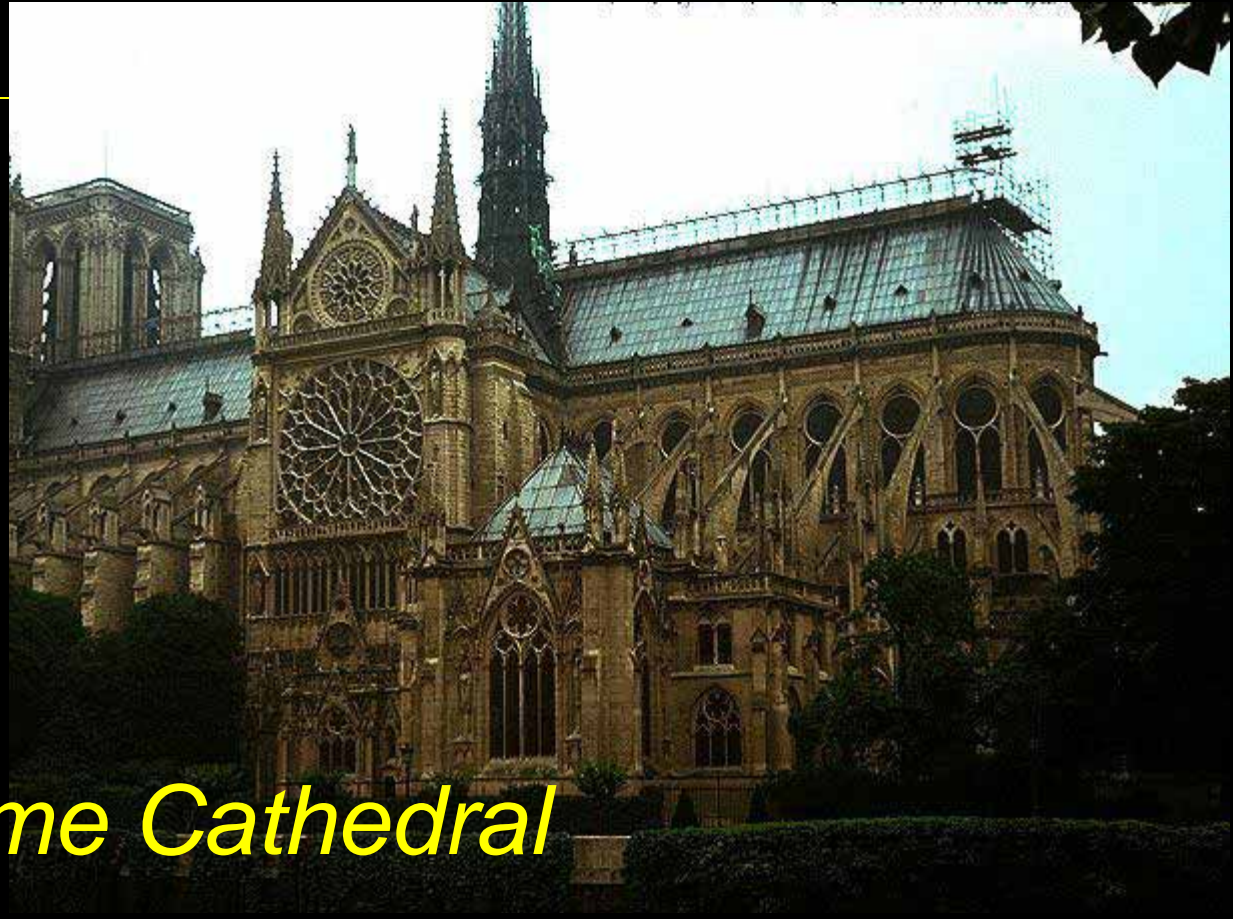

Notre Dame Cathedral
Paris, France
Maurice de Sully

Introduction 37
Lecture 1

Architectural Structures I
ENDS 231

S2008abn



Habitat 67, Montreal

Moshe Safdie (1967)

Introduction 38
Lecture 1

Architectural Structures I
ENDS 231

S2008abn



Villa Savoye, Poissy, France
Le Corbusier (1929)

Introduction 39
Lecture 1

Architectural Structures I
ENDS 231

S2008abn



Riola Parish Church
Riola, Italy
Alvar Aalto (1978)



www.GreatBuildings.com

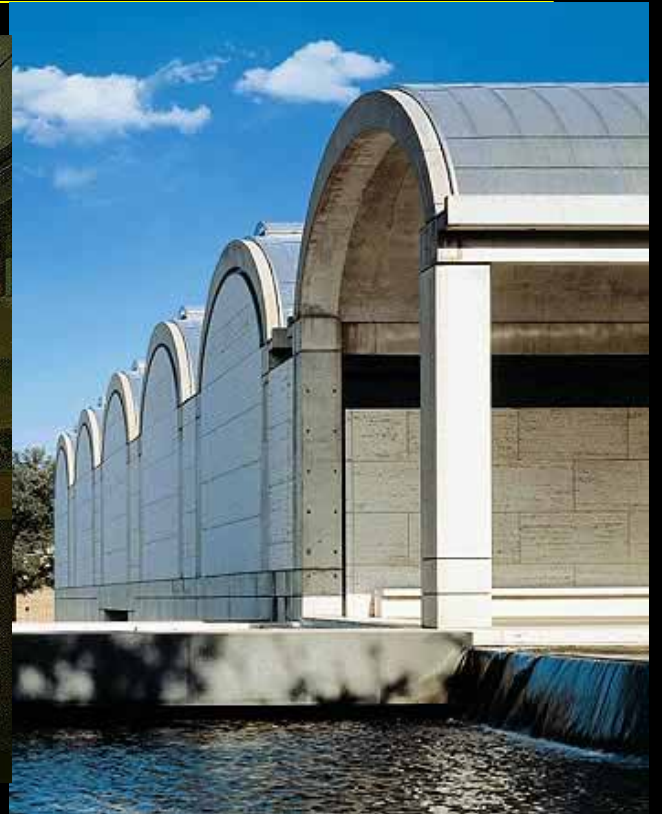

Kimball Museum, Fort Worth

Kahn (1972)

Introduction 41
Lecture 1

Architectural Structures I
ENDS 231

S2008abn

Structural Math

- *quantify environmental loads*
 - *how big is it?*
- *evaluate geometry and angles*
 - *where is it?*
 - *what is the scale?*
 - *what is the size in a particular direction?*
- *quantify what happens in the structure*
 - *how big are the internal forces?*
 - *how big should the beam be?*

Structural Math

- *physics takes observable phenomena and relates the measurement with rules: mathematical relationships*
- *need*
 - *reference frame*
 - *measure of length, mass, time, direction, velocity, acceleration, work, heat, electricity, light*
 - *calculations & geometry*

Physics for Structures

- *measures*
 - *US customary & SI*

<i>Units</i>	<i>US</i>	<i>SI</i>
<i>Length</i>	<i>in, ft, mi</i>	<i>mm, cm, m</i>
<i>Volume</i>	<i>gallon</i>	<i>liter</i>
<i>Mass</i>	<i>lb mass</i>	<i>g, kg</i>
<i>Force</i>	<i>lb force</i>	<i>N, kN</i>
<i>Temperature</i>	<i>F</i>	<i>C</i>

Physics for Structures

- *scalars – any quantity*
- *vectors - quantities with direction*
 - *like displacements*
 - *summation results in the “straight line path” from start to end*
 - *normal vector is perpendicular to something*

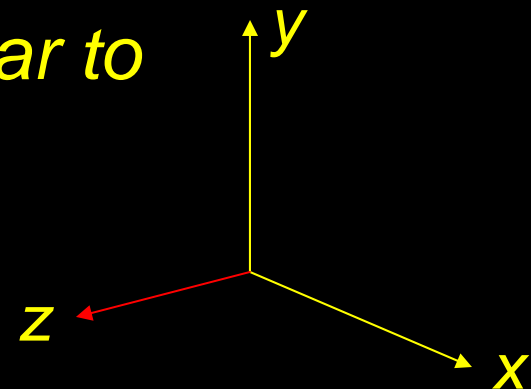
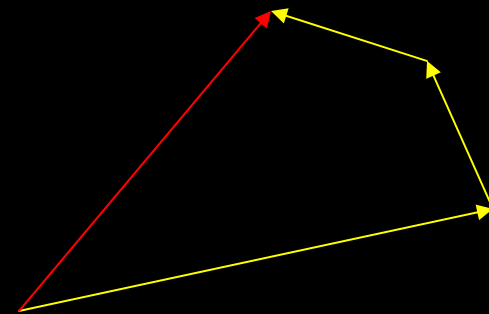

Language

- symbols for operations: +, -, /, x
- symbols for relationships: (), =, <, >
- algorithms

– cancellation

$$\frac{2}{5} \times \frac{5}{6} = \frac{2}{6} = \frac{2}{2 \times 3} = \frac{1}{3}$$

– factors

– signs

$$\frac{x}{6} = \frac{1}{3}$$

– ratios and proportions

– power of a number

$$10^3 = 1000$$

– conversions, ex. $1X = 10 Y$

– operations on both sides of equality

$$\frac{10Y}{1X} \text{ or } \frac{1X}{10Y} = 1$$

On-line Practice

- *Vista / Resources*

The screenshot shows a Mozilla Firefox browser window with the address bar displaying `https://lms.tamu.edu - Assessment - Mozilla Firefox`. The main content area is titled "Math Practice" and includes the following information:

- Math Practice**
- Anne B Nichols
- Started: August 31, 2007 10:47 AM
- Questions: 20

Instructions
This assessment is only for self-grading.

1. Force - metric to US (kN) (Points: 10.0)
Convert the force 6.85 kN to pounds (1) and kips (2).
[Provide the number without the units.]

1.
2.

Question Status

- Unanswered
- Answer not saved
- Answered

A grid of 20 question status indicators is shown, with each indicator consisting of a number (1-20) above a yellow circle. All circles are currently empty, indicating that no questions have been answered.

The browser's status bar at the bottom shows "Done" on the left and "lms.tamu.edu" on the right.

Geometry

- *angles*

- *right* = 90°

- *acute* < 90°

- *obtuse* > 90°

- π = 180°

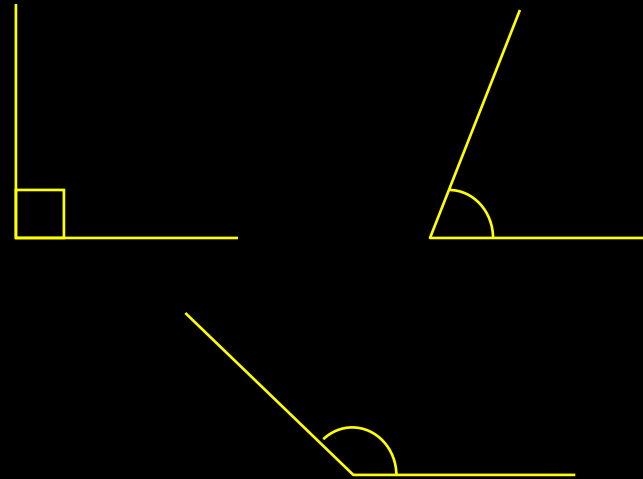

- *triangles*

- *area* = $\frac{b \times h}{2}$

- *hypotenuse*

- *total of angles* = 180°

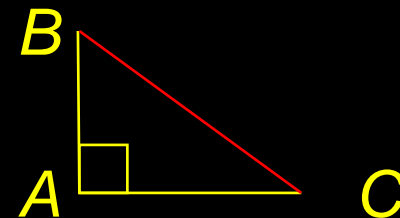

$$AB^2 + AC^2 = BC^2$$

Geometry

- *lines and relation to angles*
 - *parallel lines can't intersect*
 - *perpendicular lines cross at 90°*
 - *intersection of two lines is a point*
 - *opposite angles are equal when two lines cross*

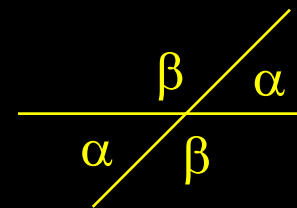
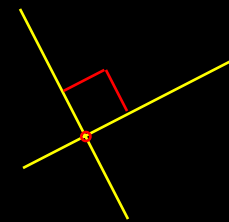
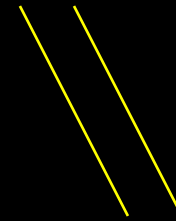

Geometry

- *intersection of a line with parallel lines results in identical angles*
- *two lines intersect in the same way, the angles are identical*

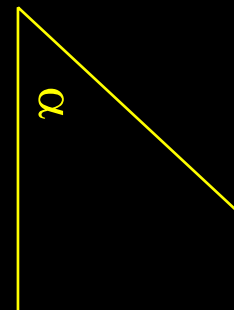
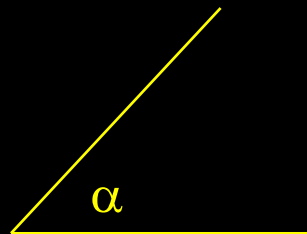
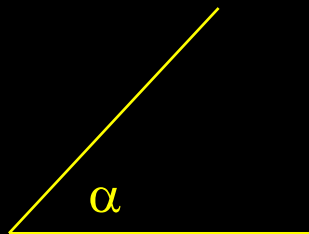
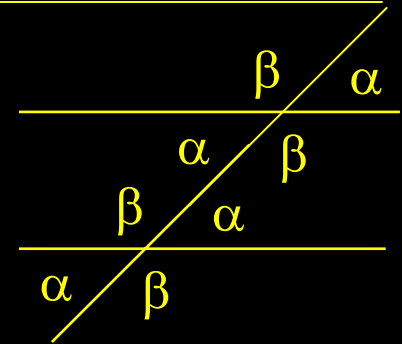

Geometry

- sides of two angles are parallel and intersect opposite way, the angles are supplementary - the sum is 180°

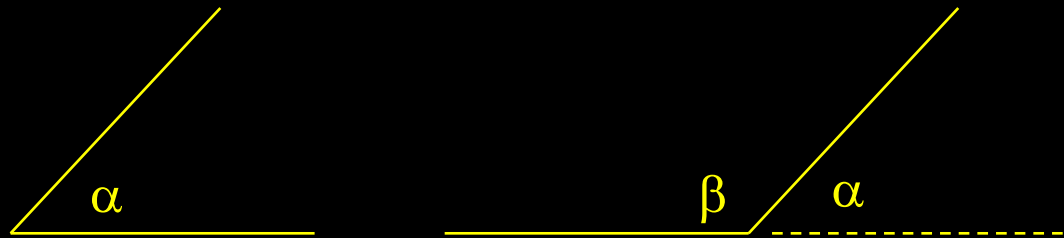

- two angles that sum to 90° are said to be complimentary

$$\beta + \gamma = 90^\circ$$

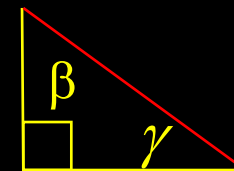

Geometry

- sides of two angles bisect a right angle (90°), the angles are complimentary

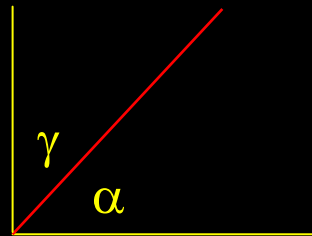

$$\alpha + \gamma = 90^\circ$$

- right angle bisects a straight line, remaining angles are complimentary

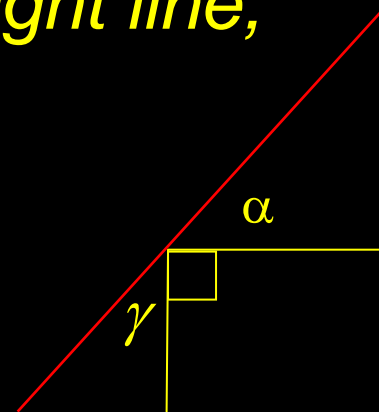

Geometry

– similar triangles have proportional sides

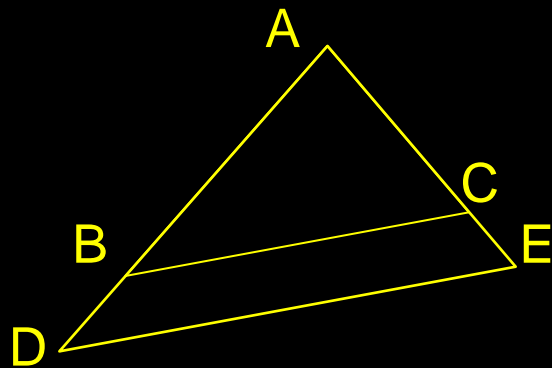

$$\frac{AB}{AD} = \frac{AC}{AE} = \frac{BC}{DE}$$

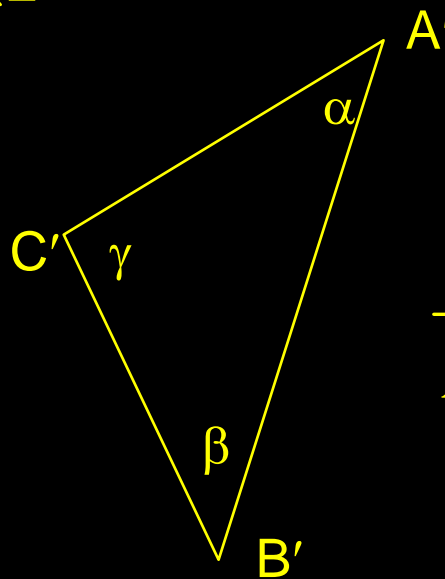
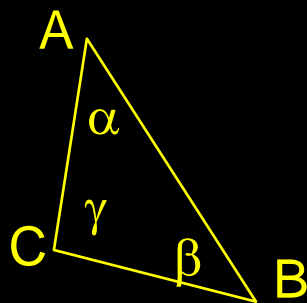

$$\frac{AB}{A'B'} = \frac{AC}{A'C'} = \frac{BC}{B'C'}$$

Trigonometry

- for right triangles

$$\sin = \frac{\textit{opposite side}}{\textit{hypotenuse}} = \sin \alpha = \frac{AB}{CB}$$

$$\cos = \frac{\textit{adjacent side}}{\textit{hypotenuse}} = \cos \alpha = \frac{AC}{CB}$$

$$\tan = \frac{\textit{opposite side}}{\textit{adjacent side}} = \tan \alpha = \frac{AB}{AC}$$

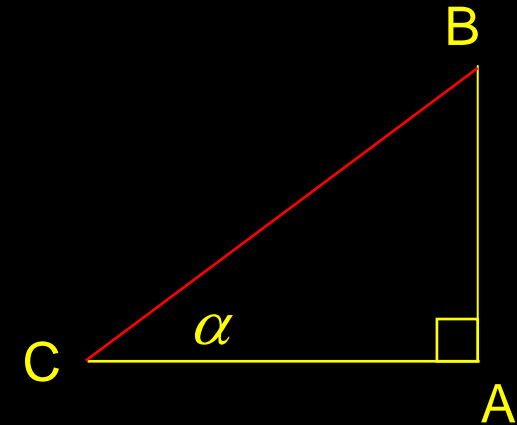

SOHCAHTOA

Trigonometry

- *cartesian coordinate system*
 - origin at $0,0$
 - coordinates in (x,y) pairs
 - x & y have signs

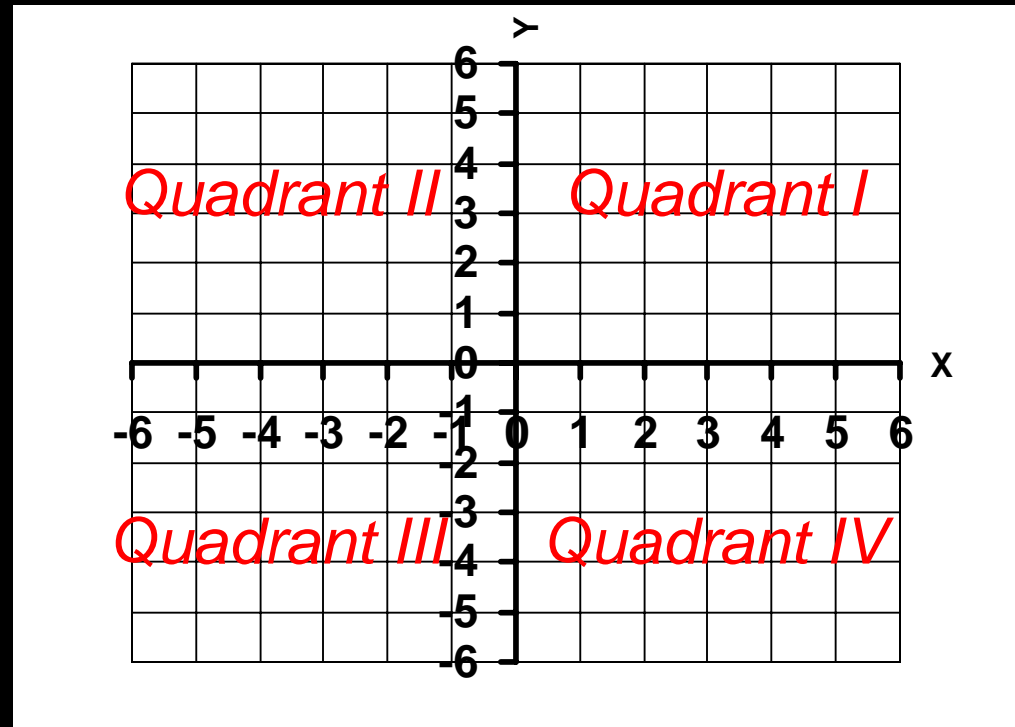

Trigonometry

- for angles starting at positive x
 - sin is y side
 - cos is x side

$\sin < 0$ for $180-360^\circ$
 $\cos < 0$ for $90-270^\circ$
 $\tan < 0$ for $90-180^\circ$
 $\tan < 0$ for $270-360^\circ$

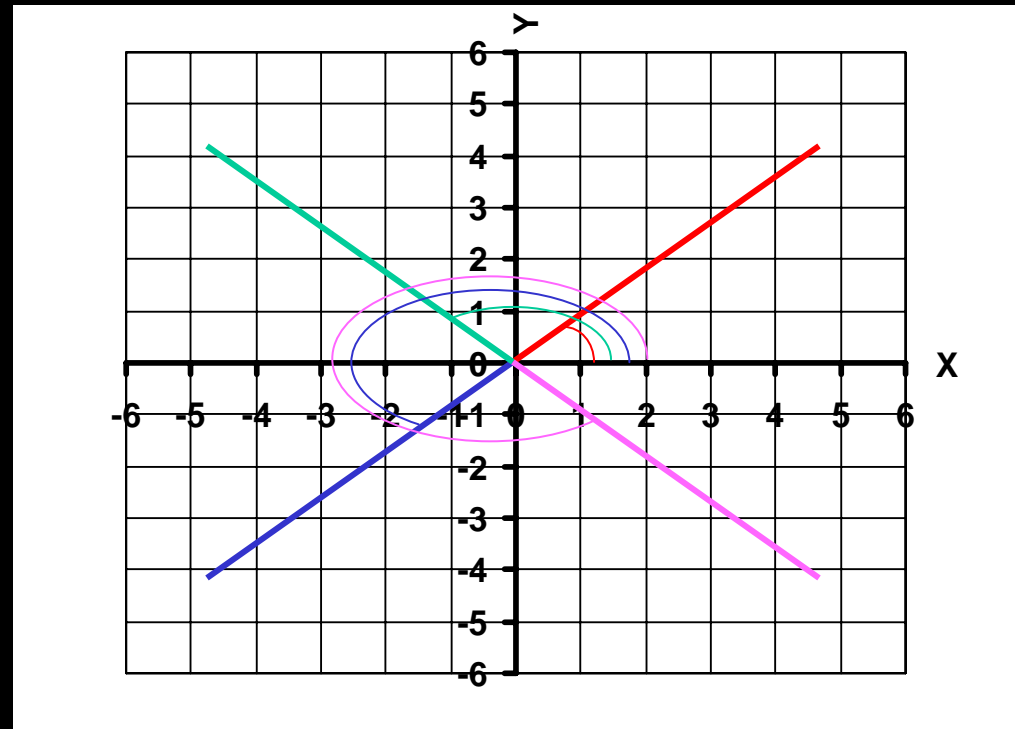

Trigonometry

- for all triangles
 - sides A , B & C are opposite angles α , β & γ

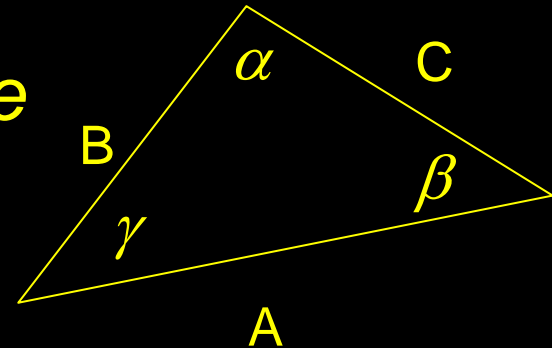

- LAW of SINES

$$\frac{\sin \alpha}{A} = \frac{\sin \beta}{B} = \frac{\sin \gamma}{C}$$

- LAW of COSINES

$$A^2 = B^2 + C^2 - 2BC \cos \alpha$$

Algebra

- *equations (something = something)*
- *constants*
 - *real numbers or shown with a, b, c...*
- *unknown terms, variables*
 - *names like R, F, x, y*
- *linear equations*
 - *unknown terms have no exponents*
- *simultaneous equations*
 - *variable set satisfies all equations*

Algebra

- *solving one equation*

- *only works with one variable*

- *ex:*

- *add to both sides*

$$2x - 1 = 0$$

$$2x - 1 + 1 = 0 + 1$$

$$2x = 1$$

- *divide both sides*

$$\frac{2x}{2} = \frac{1}{2}$$

- *get x by itself on a side*

$$x = \frac{1}{2}$$

Algebra

- *solving one equations*

- *only works with one variable*

- *ex:* $2x - 1 = 4x + 5$

- *subtract from both sides*

$$2x - 1 - 2x = 4x + 5 - 2x$$

- *subtract from both sides*

$$-1 - 5 = 2x + 5 - 5$$

- *divide both sides*

$$\frac{-6}{2} = \frac{-3 \cdot 2}{2} = \frac{2x}{2}$$

- *get x by itself on a side*

$$x = -3$$

Algebra

- *solving two equation*

- *only works with two variables*

- *ex:*

$$2x + \underline{3y} = 8$$

- *look for term similarity*

$$12x - \underline{3y} = 6$$

- *can we add or subtract to eliminate one term?*

- *add*

$$2x + 3y + 12x - 3y = 8 + 6$$

$$14x = 14$$

- *get x by itself on a side*

$$\frac{14x}{14} = \frac{14}{14} = x = 1$$