

rigid body equilibrium

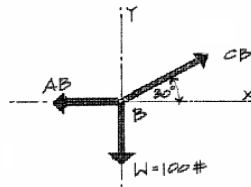

Free Body Diagram

- FBD (sketch)
- tool to see all forces on a body or a point including
 - external forces
 - weights
 - force reactions
 - external moments
 - moment reactions
 - internal forces



(Example 1)

Equilibrium

- rigid body
 - doesn't deform
 - coplanar force systems

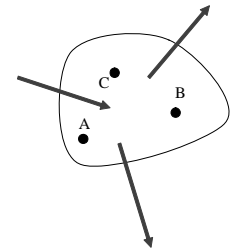

- static:

$$R_x = \sum F_x = 0$$

$$R_y = \sum F_y = 0$$

$$M = \sum M = 0$$

Free Body Diagram

- determine body
- FREE it from:
 - ground
 - supports & connections
- draw all external forces acting ON the body
 - reactions
 - applied forces
 - gravity

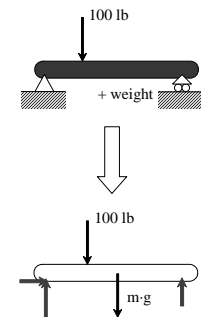

Free Body Diagram

- include relevant geometry
 - guidelines helpful to see moment arms
- name and/or color the unknown
 - forces
 - moments
 - angles
- solve up to 3 equations

Reactions

- result of applying force
- unknown size
- connection or support type
 - known direction
 - related to motion prevented

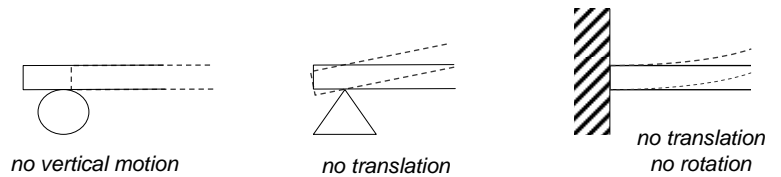

Supports and Connections

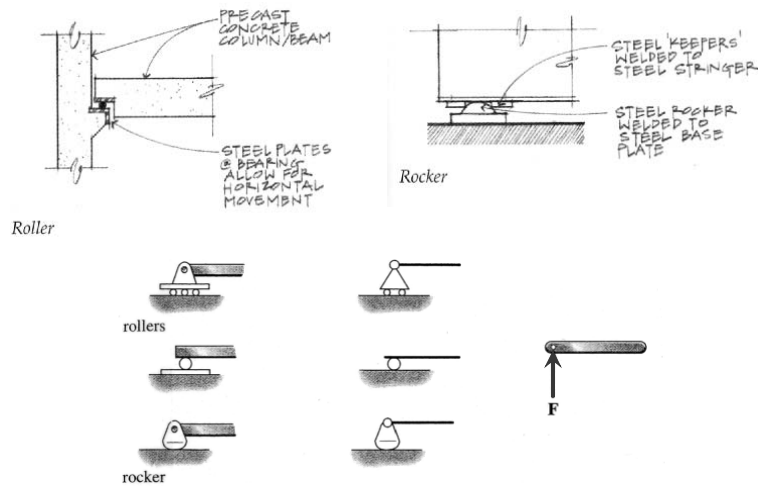

Supports and Connections

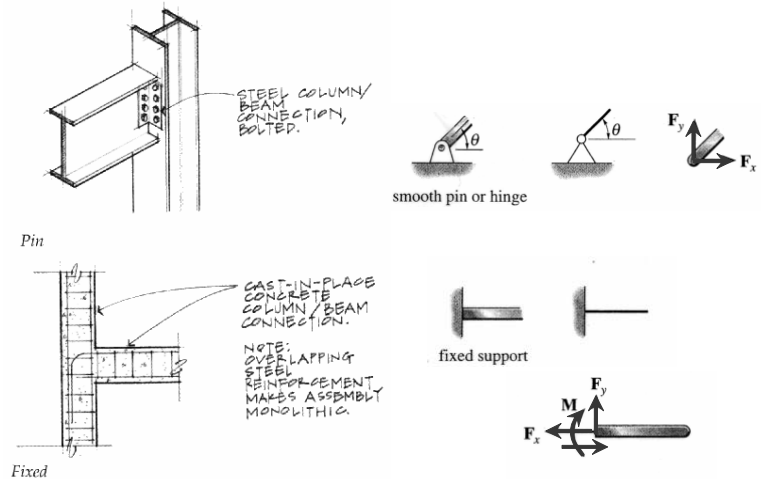

FBD Example

- 500 lb known
- pin – A_x, A_y
- smooth surface – B at 4:3
- 3 equations
- sum moments at
 - A?
 - B? (B_x)

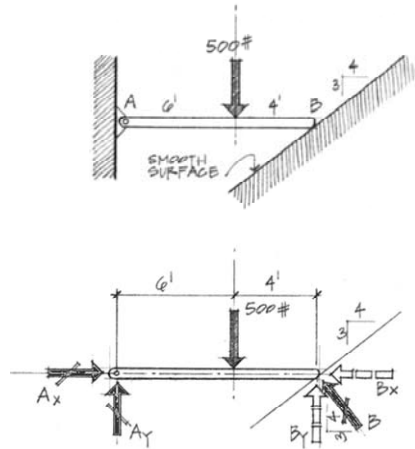

Moment Equations

- sum moments at intersection where the most forces intersect
- multiple moment equations may not be useful
- combos:

$$\begin{array}{lll} \sum F_x = 0 & \sum F = 0 & \sum M_1 = 0 \\ \sum F_y = 0 & \sum M_1 = 0 & \sum M_2 = 0 \\ \sum M_1 = 0 & \sum M_2 = 0 & \sum M_3 = 0 \end{array}$$

Recognizing Reactions

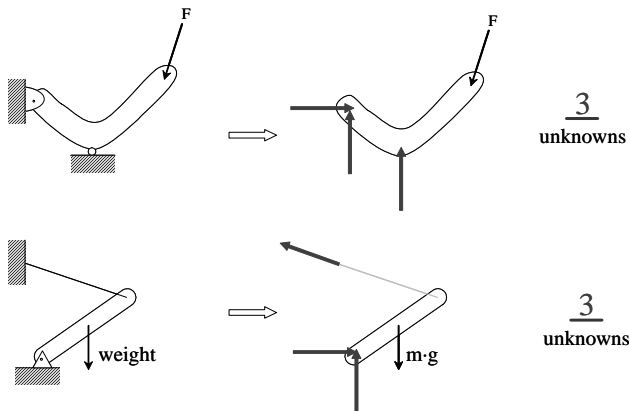

Recognizing Reactions

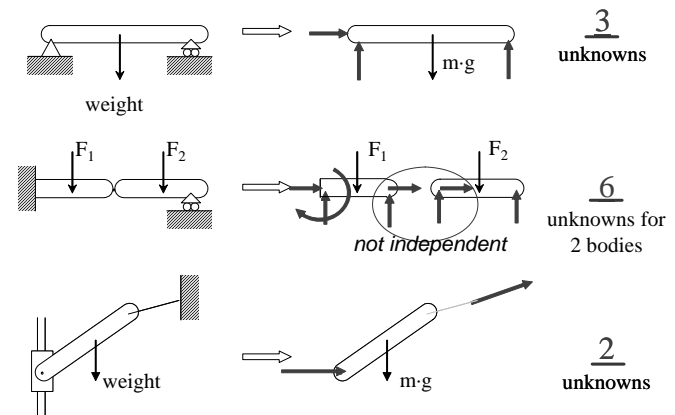

Constraints

- *completely constrained*
 - doesn't move
 - may not be statically determinate
- *improperly or partially constrained*
 - has \leq unknowns
 - can't solve

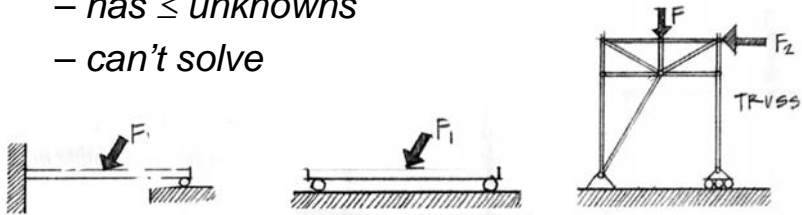

Rigid Bodies and Supports 14

Architectural Structures I
ENDS 231

S2004abn

Constraints

- *overconstrained*
 - won't move
 - can't be solved with statics
 - statically indeterminate to n^{th} degree

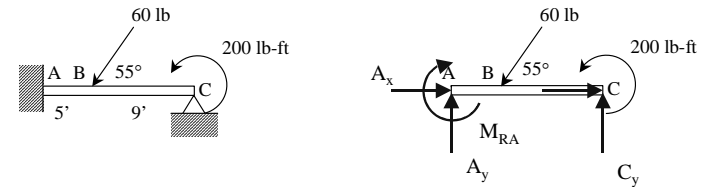

Rigid Bodies and Supports 15

Architectural Structures I
ENDS 231

S2004abn

Partial Constraints

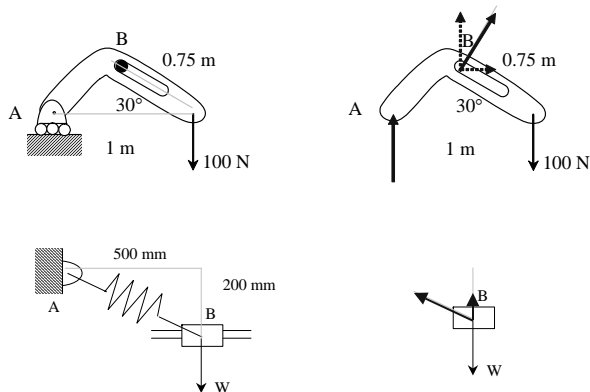

Rigid Bodies and Supports 16

Architectural Structures I
ENDS 231

S2004abn

Two Force Rigid Bodies

- *equilibrium:*
 - forces in line, equal and opposite

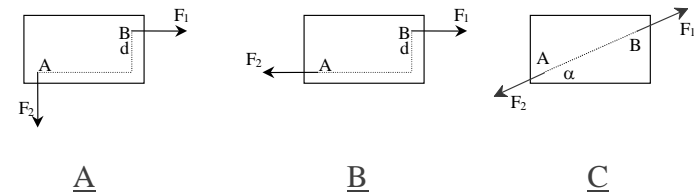

Rigid Bodies and Supports 22

Architectural Structures I
ENDS 231

S2004abn

Three Force Rigid Bodies

- *equilibrium:*
 - *concurrent or parallel forces*

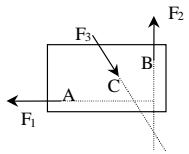

A

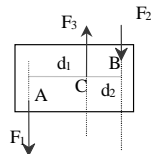

B

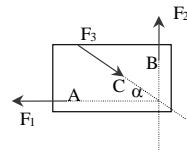

C

Rigid Bodies and Supports 18

Architectural Structures I
ENDS 231

S2004abn

Cable Reactions

- *equilibrium:*
 - *more reactions (4) than equations*
 - *but, we have slope relationships*
 - *x component the same everywhere*

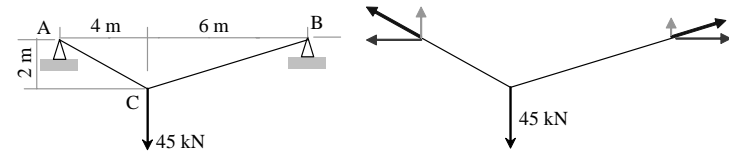

Rigid Bodies and Supports 24

Architectural Structures I
ENDS 231

S2004abn