

ENDS 231. Assignment #12

Date: 4/19/07, due 4/26/07

Pass-fail work

Problems:

*Note: Problems marked with a * have been altered with respect to the problem stated in the text.*

12A) Determine the capacity of this butt splice based on shear, bearing, and net tension. The plates are made of A36 steel and the four bolts on each side of the splice are A325-SC with standard round holes.

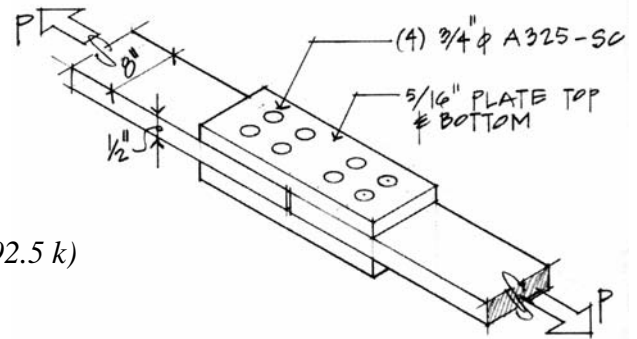

Partial answers to check with:

$$P = 60 \text{ k (shear governs with } P_b = 104.4 \text{ k and } P_{t-gross} = 86.4 \text{ k, } P_{t-net} = 92.5 \text{ k)}$$

12B) Determine the capacity of the welded connection shown. The weld size is 3/16 in.. Assume the base metal is A36 steel and electrodes are E70XX in each problem. Use $L = 4.5''$.

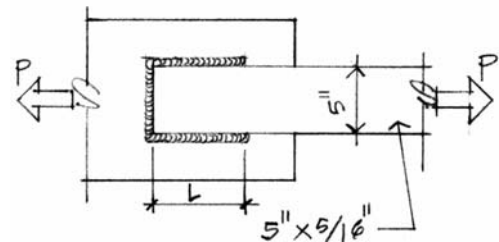

Partial answers to check with:

$$P_v = 38.9 \text{ k, } P_t = 33.75 \text{ k}$$

12C) For the rigid frame shown, the reactions at A are: $A_x = -7.45 \text{ kN}$, $A_y = -7.29 \text{ kN}$, $M_A = 21.05 \text{ kN}\cdot\text{m}$. The reactions at D are: $D_x = -4.55 \text{ kN}$, $D_y = 7.30 \text{ kN}$, $M_D = 11.07 \text{ kN}\cdot\text{m}$. Plot the shear and bending moment diagrams and identify V_{max} and M_{max} .

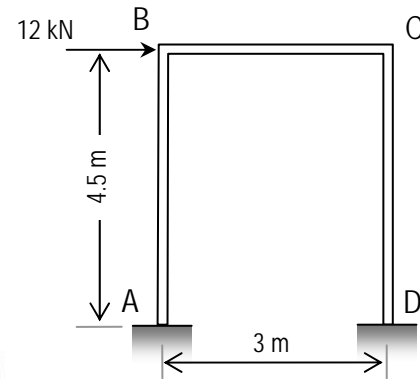

Partial answers to check with:

$$M_{BA} = 12.49 \text{ kN}\cdot\text{m}, M_{CB} = -9.4 \text{ kN}\cdot\text{m}, V_{max} = 7.45 \text{ kN}, M_{max} = -21.05 \text{ kN}\cdot\text{m}$$

