

Stress and Strain – Elasticity

Normal Strain

In an axially loaded member, normal strain, ϵ is the change in the length, δ with respect to the original length, L .

$$\epsilon = \frac{\delta}{L}$$

It is UNITLESS, but may be called strain or microstrain (μ).

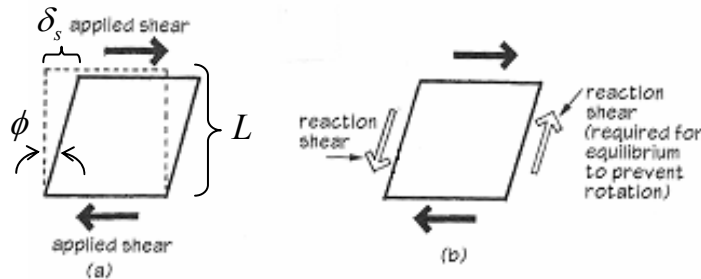
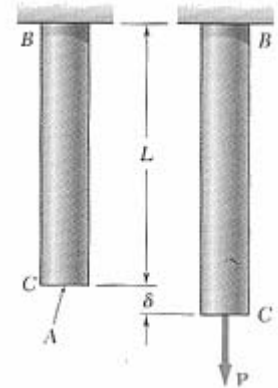

Shearing Strain

In a member loaded with shear forces, shear strain, γ is the change in the sheared side, δ_s with respect to the original height, L . For small angles: $\tan \phi \cong \phi$.

$$\gamma = \frac{\delta_s}{L} = \tan \phi \cong \phi$$

In a member subjected to twisting, the shearing strain is a measure of the angle of twist with respect to the length and distance from the center, ρ :

$$\gamma = \frac{\rho\phi}{L}$$

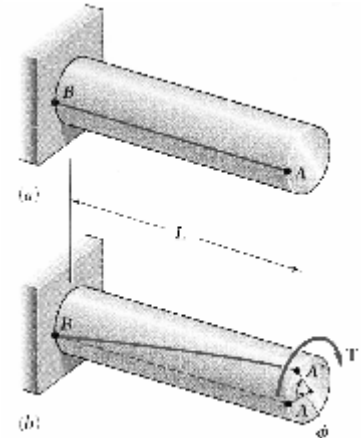

Testing of Load vs. Strain

Behavior of materials can be measured by recording deformation with respect to the size of the load. For members with constant cross section area, we can plot stress vs. strain.

BRITTLE MATERIALS - ceramics, glass, stone, cast iron; show abrupt fracture at small strains.

DUCTILE MATERIALS – plastics, steel; show a yield point and large strains (considered *plastic*) and “necking” (give warning of failure)

SEMI-BRITTLE MATERIALS – concrete; show no real yield point, small strains, but have some “strain-hardening”.

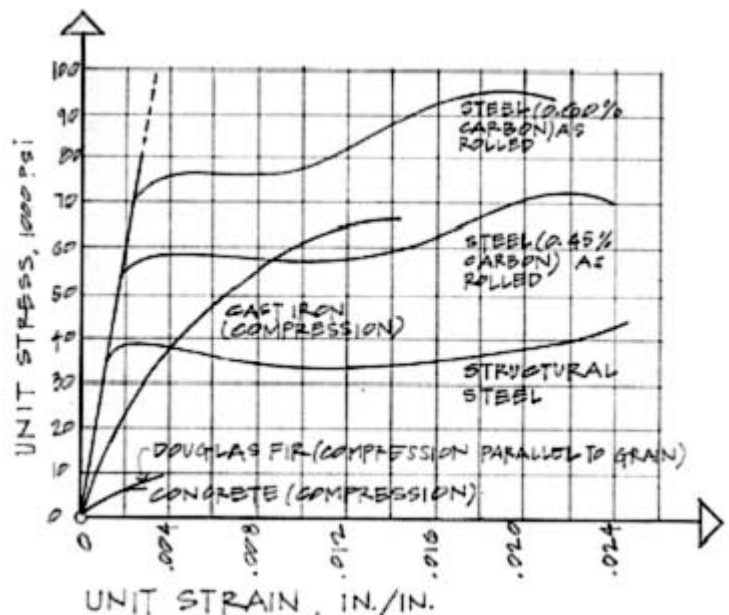

Linear-Elastic Behavior

In the straight portion of the stress-strain diagram, the materials are *elastic*, which means if they are loaded and unloaded no permanent _____ occurs.

True Stress & Engineering Stress

True stress takes into account that the area of the cross section changes with loading.

Engineering stress uses the original area of the cross section.

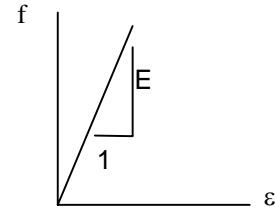

Hooke's Law – Modulus of Elasticity

In the linear-elastic range, the slope of the stress-strain diagram is *constant*, and has a value of E , called Modulus of Elasticity or Young's Modulus.

$$f = E \cdot \varepsilon$$

Isotropic Materials – have the _____ E with any direction of loading.

Anisotropic Materials – have _____ E 's with the direction of loading.

Plastic Behavior & Fatigue

Permanent deformations happen outside the linear-elastic range and are called *plastic* deformations. Fatigue is damage caused by reversal of loading.

- The proportional limit (at the end of the _____ range) is the greatest stress valid using Hooke's law.
- The elastic limit is the maximum stress that can be applied before permanent deformation would appear upon unloading.
- The yield point (at the *yield* _____) is where a ductile material continues to elongate without an increase of load. (May not be well defined on the stress-strain plot.)
- The ultimate strength is the largest stress a material will see before rupturing, also called the *tensile strength*.
- The rupture strength is the stress at the point of rupture or failure. It may not coincide with the ultimate strength in ductile materials. In brittle materials, it will be the same as the ultimate strength.
- The fatigue strength is the stress at failure when a member is subjected to reverse cycles of stress (up & down or compression & tension). This can happen at much lower values than the ultimate strength of a material.

- Toughness of a material is how much work (a combination of stress and strain) is used for fracture. It is the area under the stress-strain curve.

Concrete does not respond well to tension and is tested in compression. The strength at crushing is called the *compression strength*.

Materials that have time dependent elongations when loaded are said to have *creep*. Concrete and wood creep. Concrete also has the property of shrinking over time.

Poisson’s Ratio

For an isotropic material that is homogeneous, the properties are the same for the cross section:

$$\epsilon_y = \epsilon_z$$

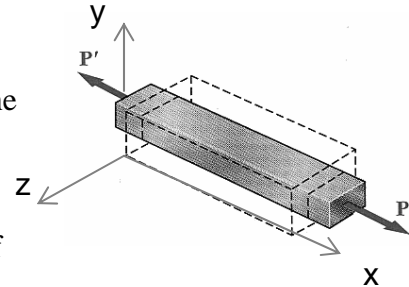

There exists a linear relationship while in the linear-elastic range of the material between *longitudinal strain* and *lateral strain*:

$$\mu = -\frac{\text{lateral strain}}{\text{axial strain}} = -\frac{\epsilon_y}{\epsilon_x} = -\frac{\epsilon_z}{\epsilon_x} \quad \epsilon_y = \epsilon_z = -\frac{\mu f_x}{E}$$

Positive strain results from an increase in length with respect to overall length.

Negative strain results from a decrease in length with respect to overall length.

μ is the Poisson’s ratio and has a value between 0 and 1/2, depending on the material

Relation of Stress to Strain

$$f = \frac{P}{A}; \quad \epsilon = \frac{\delta}{L} \quad \text{and} \quad E = \frac{f}{\epsilon} \quad \text{so} \quad E = \frac{P/A}{\delta/L} \quad \text{which rearranges to:} \quad \delta = \frac{PL}{AE}$$

Orthotropic Materials

One class of non-isotropic materials is *orthotropic materials* that have directionally based values of modulus of elasticity and Poisson’s ratio (E, μ).

Ex: plywood, laminates, fiber reinforced polymers with direction fibers

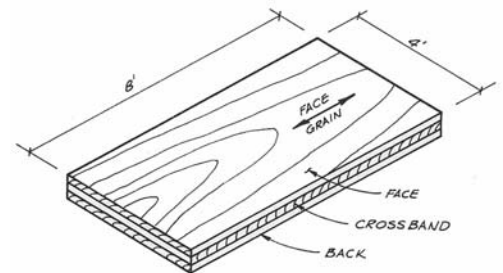

Stress Concentrations

In some sudden changes of cross section, the stress concentration changes (and is why we used *average* normal stress). Examples are sharp notches, or holes or corners.

(Think about airplane window shapes...)

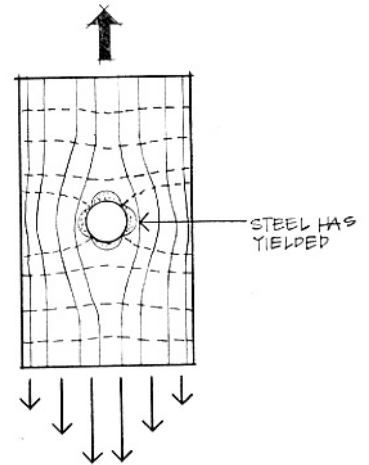

Maximum Stress

When both normal stress and shear stress occur in a structural member, the *maximum stresses can occur at some other planes* (angle of θ).

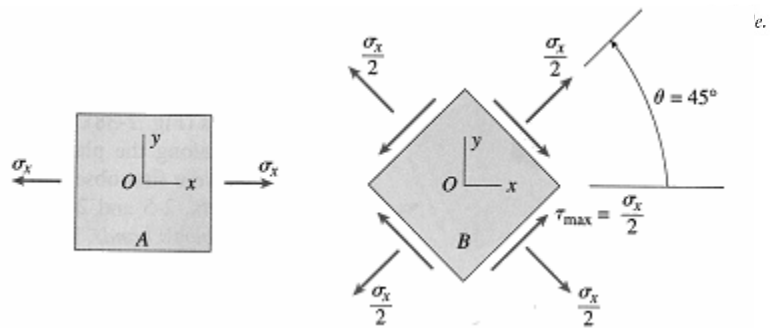

Maximum Normal Stress happens at $\theta = 0^\circ$ AND

Maximum Shearing Stress happens at $\theta = 45^\circ$ with only normal stress in the x direction.

Allowable Stress Design (ASD) and Factor of Safety (F.S.)

There are uncertainties in material strengths: $F.S = \frac{\text{ultimate load}}{\text{allowable load}} = \frac{\text{ultimate stress}}{\text{allowable stress}}$

Allowable stress design determines the allowable stress by: $\text{allowable stress} = \frac{\text{ultimate stress}}{F.S}$

Load and Resistance Factor Design – LRFD

There are uncertainties in material strengths *and* in structural loadings.

$$\gamma_D R_D + \gamma_L R_L \leq \phi R_u$$

- where γ = load factor for Dead and Live loads
- R = load (dead or live)
- ϕ = resistance factor
- R_n = nominal load (capacity)

Example 1 (pg 222)**Example Problem 6.19 (Figure 6.50)**

A skywalk in the atrium area of a major hotel uses a system of $1\frac{1}{4}$ " ϕ steel rods to support the dead and occupancy loads. Assuming $F_t = 22$ ksi and $E = 29 \times 10^3$ ksi, determine the following:

- the allowable load capacity in each rod;
- if the rods supporting the third-floor walkway are 30 ft. in length, how much elongation would occur if the rod was loaded to its maximum allowable stress limit;
- the ultimate load capacity of the rod at failure assuming A36 steel (see Table 6.1a)

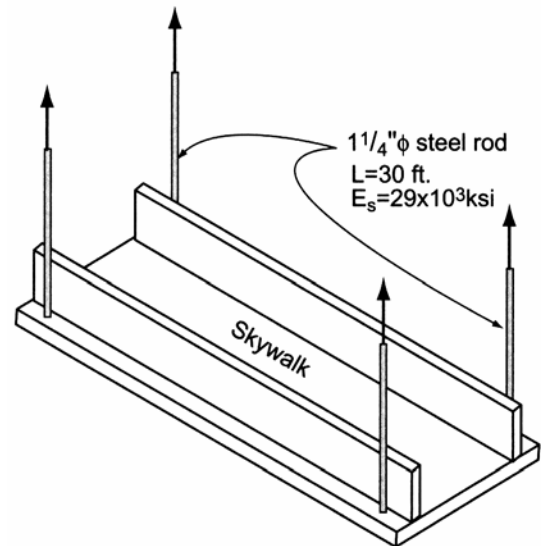

Example 2 (metric, pg 223)**Example Problem 6.20 (Figures 6.51 and 6.52)**

A log post supports a floor load P . Assuming that the post has a diameter $D_1 = 12$ in. (0.305 m), (a) determine the allowable load P if the compression stress in the post is limited to $F_{\text{allow.}} = 800 \text{ lb./in.}^2$ (5.52 MPa). Once P has been determined, (b) find the deformation (shortening) that results. Also, (c) determine the size D_2 of the circular footing necessary if the allowable soil pressure is: $q = 6000$ psf (287 kPa).

$$E_{\text{timber}} = 1.5 \times 10^3 \text{ ksi (10.34 MPa);}$$

$$\gamma_{\text{concrete}} = 150 \text{ lb./ft.}^3 \text{ (23.6 kN/m}^3\text{)}$$

Using the following design values, determine the minimum size of D_1 for bearing on the concrete:

$$\begin{aligned} \phi &= 0.70 & \gamma_D &= 1.4 \\ f'_c &= 24 \text{ MPa} & F_b &= 0.85 f'_c \end{aligned}$$

