



## stability and columns

Stability 1  
Lecture 20

Architectural Structures I  
ENDS 231

Su2004abn

## Additional Design Criteria

- designed for strength & stresses
- designed for serviceability & deflection
- need to design for stability
  - ability to support a specified load without sudden or unacceptable deformations

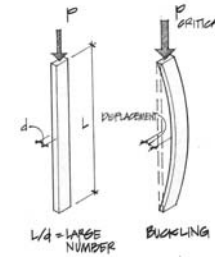

Stability 4  
Lecture 23

Architectural Structures I  
ENDS 231

S2004abn

## Column Behavior

- objects like lowest energy state

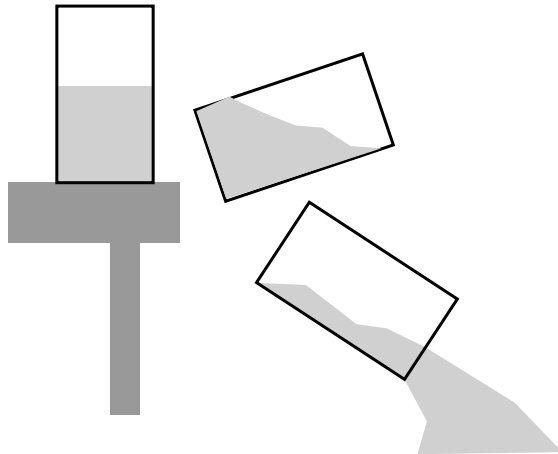

Stability 5  
Lecture 23

Architectural Structures I  
ENDS 231

S2004abn

## Stable Equilibrium

- energy added
- things don't change

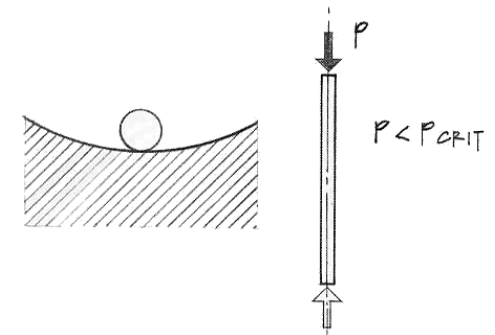

Stability 6  
Lecture 23

Architectural Structures I  
ENDS 231

S2004abn

## Neutral Equilibrium

- energy added
- things change, but not much

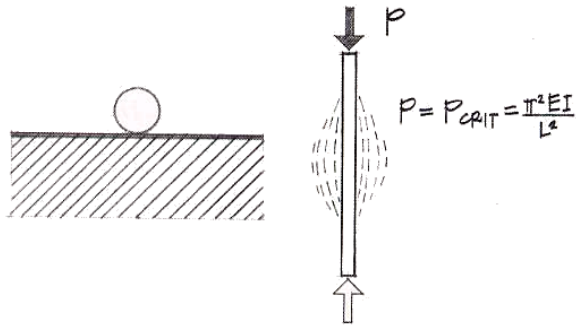

Stability 7  
Lecture 23

Architectural Structures I  
ENDS 231

S2004abn

## Unstable Equilibrium

- energy added
- things change drastically

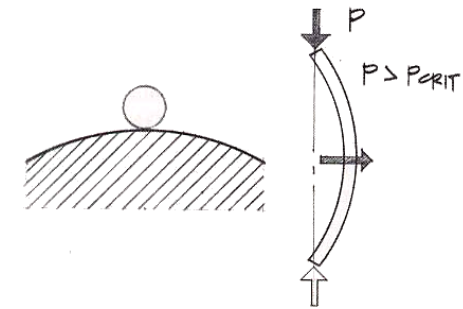

Stability 8  
Lecture 23

Architectural Structures I  
ENDS 231

S2004abn

## Column Buckling

- axially loaded columns
- long & slender
  - unstable equilibrium = buckling
  - sudden and not good

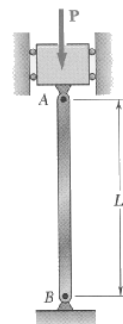

Fig. 10.1



Fig. 10.2

Stability 9  
Lecture 23

Architectural Structures I  
ENDS 231

S2004abn

## Modeling

- can be modeled with a spring at mid-height
- when moment from deflection exceeds the spring capacity ... "boing"
- critical load  $P$

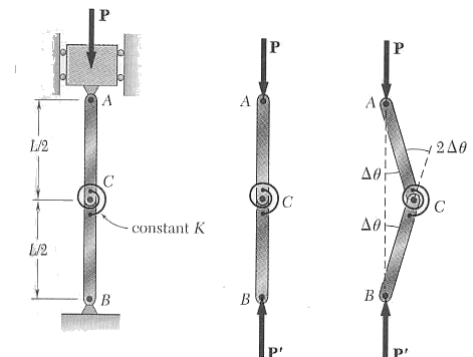

Stability 10  
Lecture 23

Architectural Structures I  
ENDS 231

S2004abn

# Effect of Length

- long & slender
- short & stubby

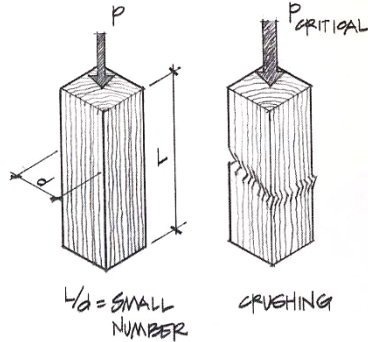
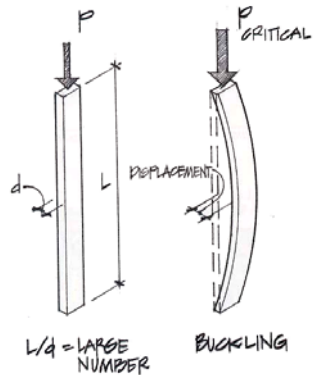

Stability 11  
Lecture 23

Architectural Structures I  
ENDS 231

S2004abn

# Buckling Load

- related to deflected shape ( $P\Delta$ )
- shape of sine wave
- Euler's Formula
- $I$  minimum

$$P_{critical} = \frac{\pi^2 EI_{min}}{(L)^2}$$

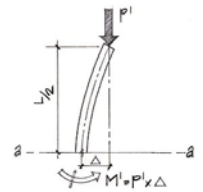

Figure 9.3 Leonhard Euler (1707-1783).

Stability 12  
Lecture 23

Architectural Structures I  
ENDS 231

S2004abn

# Critical Stress

- short columns

$$f_{critical} = \frac{P_{actual}}{A} < F_a$$

- slenderness ratio =  $L_e/r$  ( $L/d$ )

- radius of gyration =  $r = \sqrt{\frac{I}{A}}$

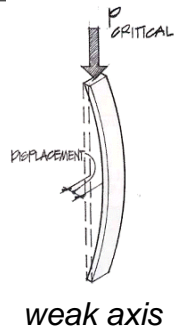

$$P_{critical} = \frac{\pi^2 EA}{\left(\frac{L_e}{r}\right)^2}$$

$$f_{critical} = \frac{P_{critical}}{A} = \frac{\pi^2 EA r^2}{A(L_e)^2} = \frac{\pi^2 E}{\left(\frac{L_e}{r}\right)^2}$$

Stability 13  
Lecture 23

Architectural Structures I  
ENDS 231

S2004abn

# Critical Stresses

- when a column gets stubby,  $F_y$  will limit the load
- real world has loads with eccentricity
- $C_c$  for steel and allowable stress

$$\frac{L_e}{r} > C_c = \sqrt{\frac{2\pi^2 E}{F_y}}$$

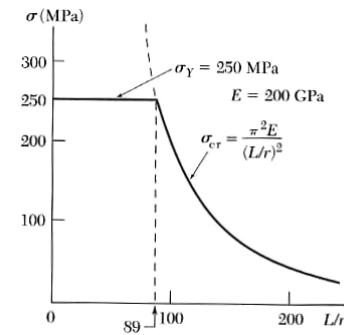

Fig. 10.9

Stability 14  
Lecture 23

Architectural Structures I  
ENDS 231

S2004abn

## Effective Length

- end conditions affect shape
- effective length factor,  $K$       $L_e = K \cdot L$

Buckled shape of column shown by dashed line	(a)	(b)	(c)	(d)	(e)	(f)
Theoretical $K$ value	0.5	0.7	1.0	1.0	2.0	2.0
Recommended design values when ideal conditions are approximated	0.65	0.80	1.0	1.2	2.10	2.0

Stability 15  
Lecture 23

Architectural Structures I  
ENDS 231

S2004abn

## Bracing

- bracing affects shape of buckle in one direction
- both should be checked!

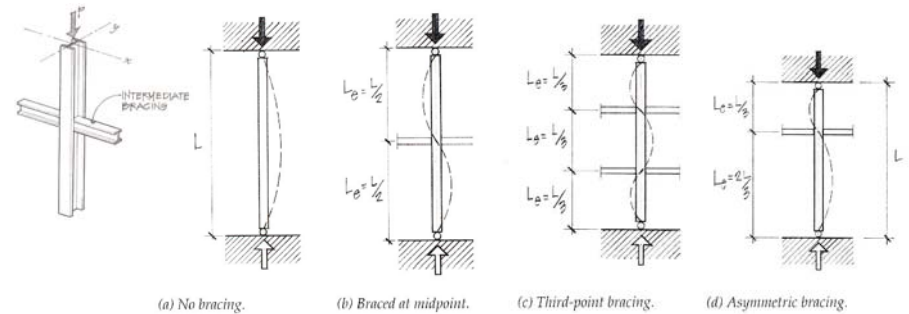

Stability 16  
Lecture 23

Architectural Structures I  
ENDS 231

S2004abn