

"According to Lao Tse, the reality of a hollow object is in the void and not in the walls that define it. He was speaking, of course, of spiritual realities..... These are the realities also of the PETRONAS Towers. The power of the void is increased and made more explicit by the pedestrian bridge that with its supporting structure creates a **portal to the sky, a door to the infinite.**"

..... Cesar Pelli, architect (1995)

Fact File

Name of the building:

PETRONAS towers

Main architect:

Cesar Pelli & Associates Architects

Local architects:

Adamson Associates International,
RSP Architects Planners &
Engineers Private Limited

Year of completion:

1998 .

Records:

The twin Towers were the world's tallest buildings, before being surpassed by the Taipei 101. However, the towers are still the tallest twin buildings and office building in the world.

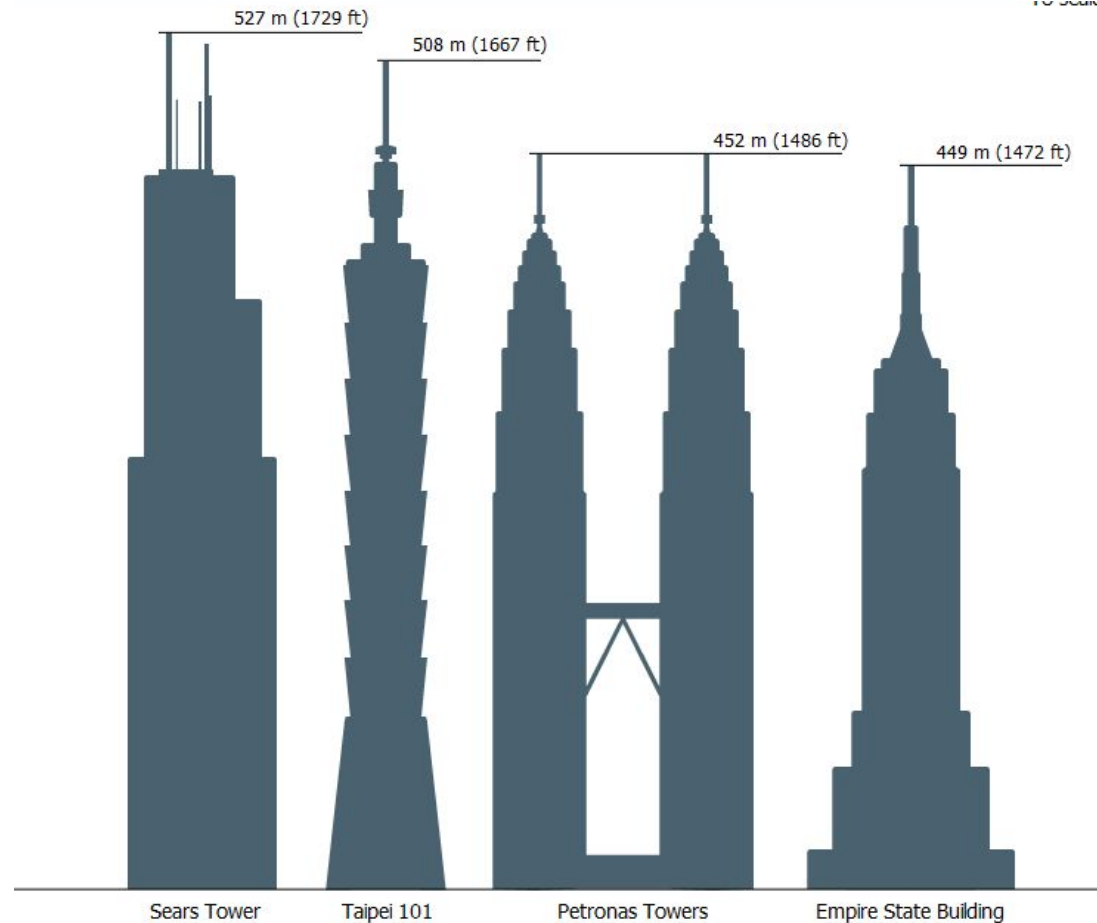

Program

Offices:

twin towers, Total gross area: 1,366,714 square meters.

Retail:

a multi-level retail centre, Total gross area 699,654 square meters.

Hotel:

a 1,800-room convention hotel and conference centre.
Total gross area: 491,289 square meters.

Parking:

integrated parking for 6,650 cars.



Design Development

The design of the towers responds to its **climate** and to formal characteristics of the dominant **Islamic culture**.

The towers are figurative and **symmetrical** and create a **figurative space** between them.

Towers are tapered and set back five times in its ascent.

The 88-floor towers are constructed largely of **reinforced concrete**, with a **steel and glass façade** designed to resemble motifs found in Islamic art.

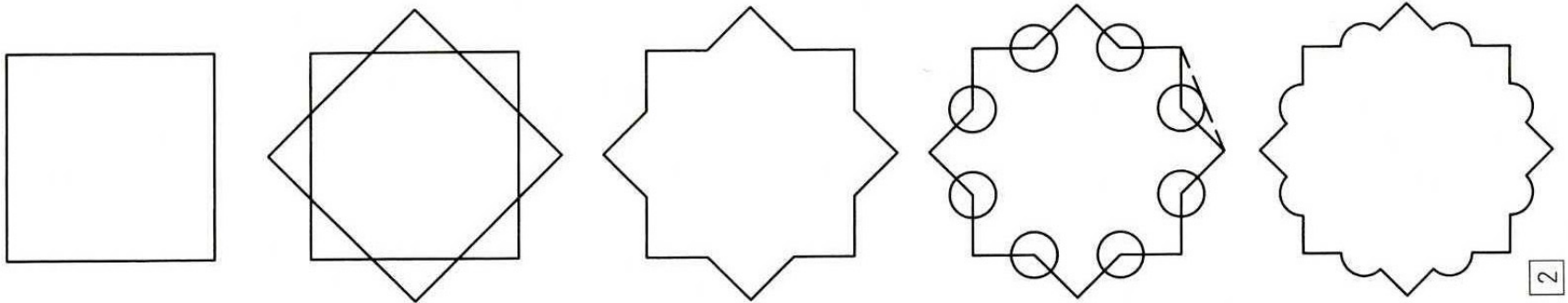

Design Development

Floor plate design:

Is based on simple Islamic geometric forms of **two interlocking squares creating a shape of eight-pointed stars.**

Upon the eight-pointed stars, are eight superimposed semi-circles softening the inner angles.

These semicircles are themselves **anchored by the arcs of the main structural columns** of the buildings.

The semi-circles were superimposed in the inner angles of the interlocked squares to create more usable floor space.

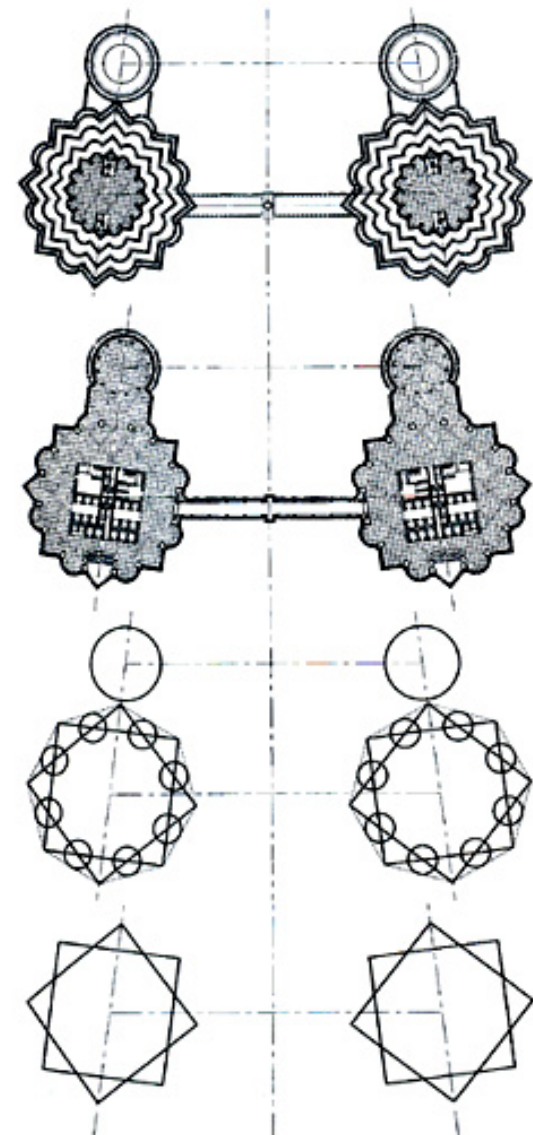

The floorplate is derived from simple geometry of interlocking squares.

Material Presence

Skin :

- Stainless steel extrusions with laminated green glass.
- Curtain wall of 33000 panels.

Concrete :

- Greater damping than steel, reduces sway- improves occupant comfort in windy conditions
- Allows members to be smaller and lighter : an advantage in very tall buildings.
- Local contractors were more familiar working with concrete.
- 10 ksi strength

Steel :

- Used for highly complex bridge because of flexibility and ease of erection compared to concrete.
- Steel is used only at top of towers.

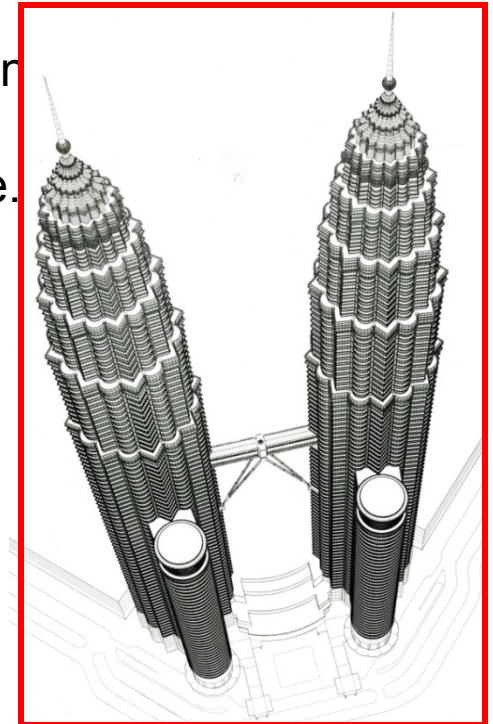

Structural Design Development

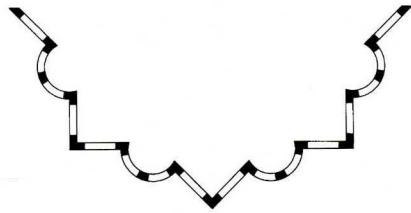

Early structural concepts studied for a concrete perimeter tube frame:

Openings happen over corners. Under wind loads, the L-shaped corner columns would experience biaxial bending and reduce frame stiffness.

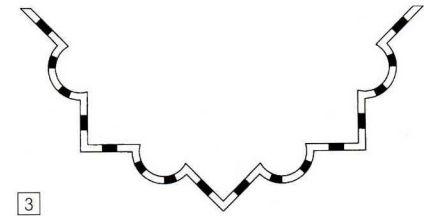

Columns occur mid-face and windows wrap around corners. Biaxial column bending and loss of frame stiffness is avoided but columns would block views.

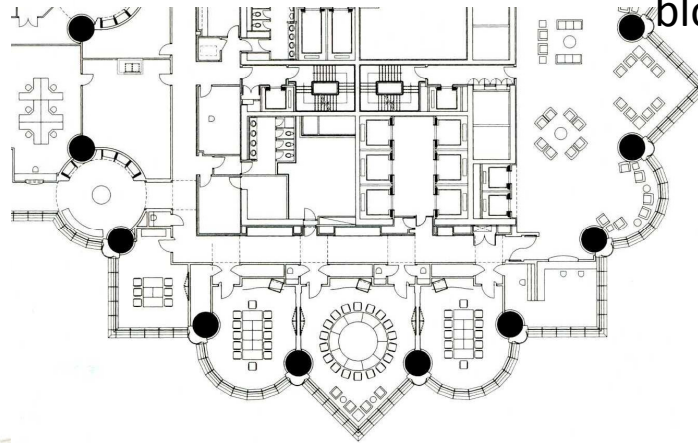

Final concept

Columns are inset to enable a continuous uninterrupted skin and enable clear view of the exterior from the interior.

Structural Systems

- Each tower is supported by a ring of 16 cylindrical columns placed on inner corners of star shaped plan. As each towers ascends, it sets back 6 times.
- Columns are sloped inward over three stories.
- Reinforcing bars are added to ring beams
- Floor slabs resist the lateral thrust.
- They form a soft tube.

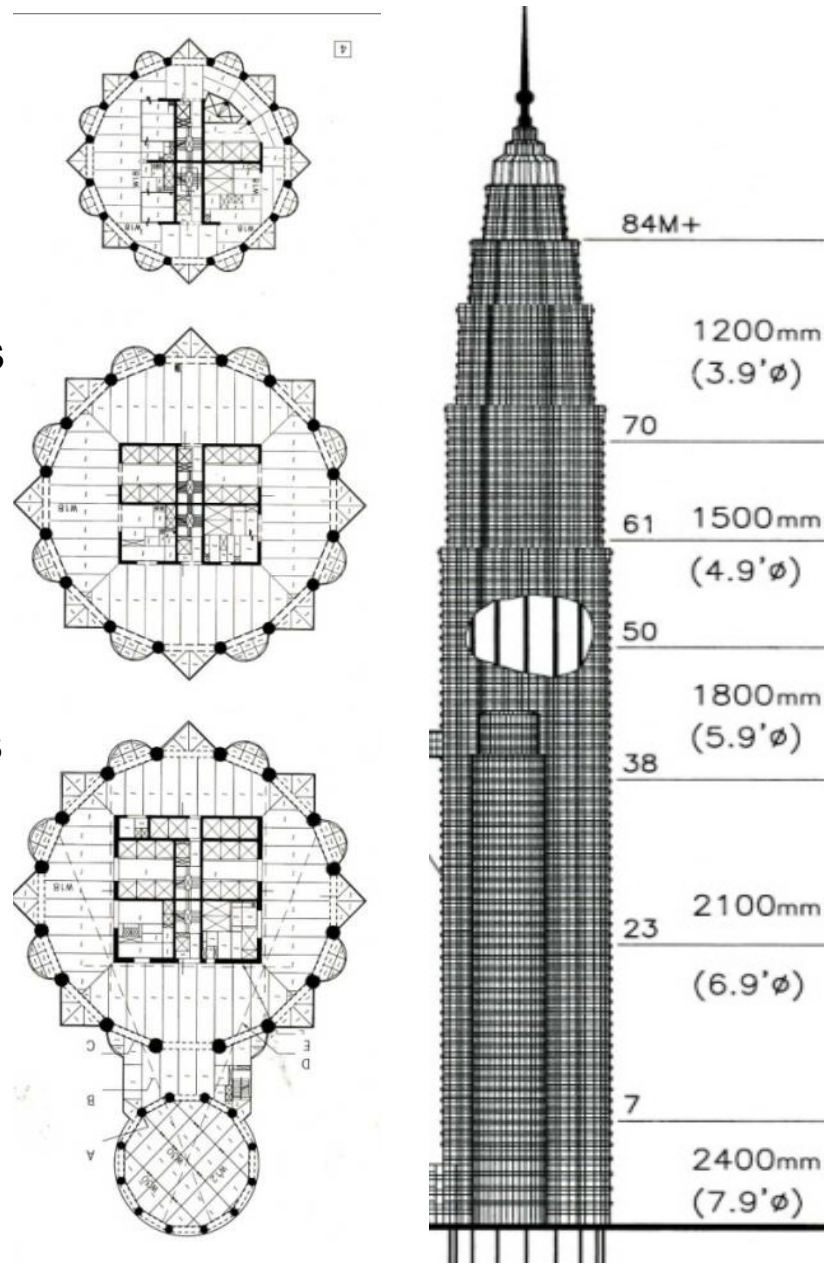

E : Core is a box of concrete shear walls.

D : Bands of steel reinforcing bars tie the bustle back to the tower core.

C : Concrete beams link the columns to form ring frames around the tower and bustle.

B : Steel beams support floor slabs, typically with 4.3inch deep concrete fill including 2inch metal deck

A : Twelve concrete columns surround the bustle, 16 columns surround the tower.

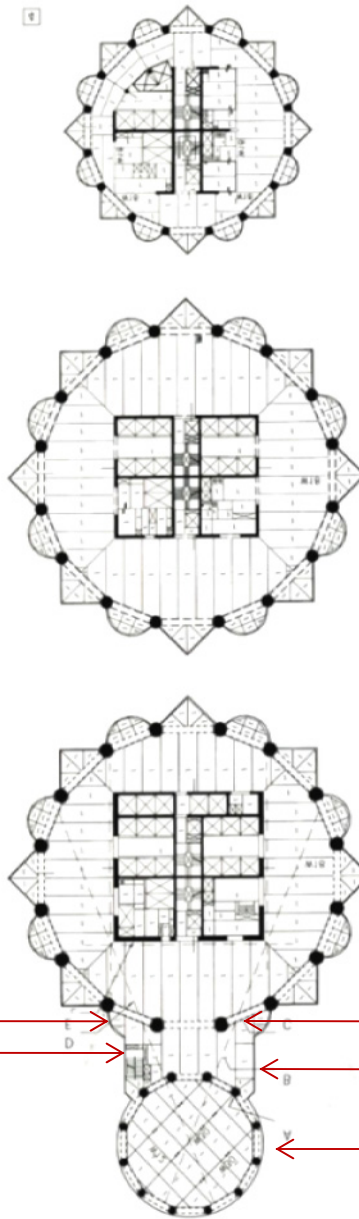

Wind & Seismic Design

Wind

- Rubber sheathed heavy galvanized ship anchor chain freely swinging within a steel pipe acts as an inexpensive, effective damper.

- Cylindrical towers sustain vortex shedding.

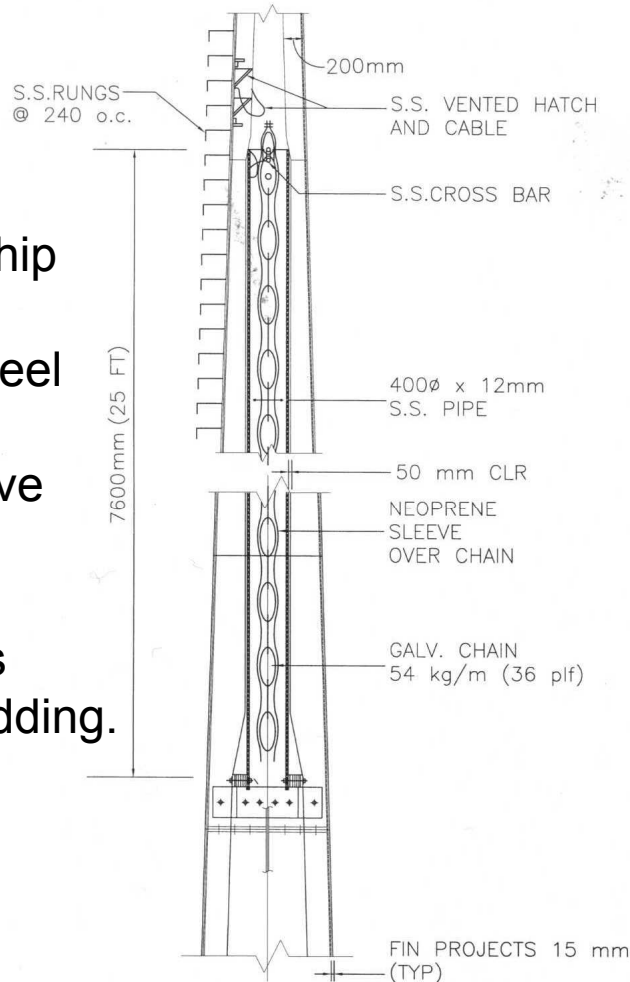

12 MAST DAMPER

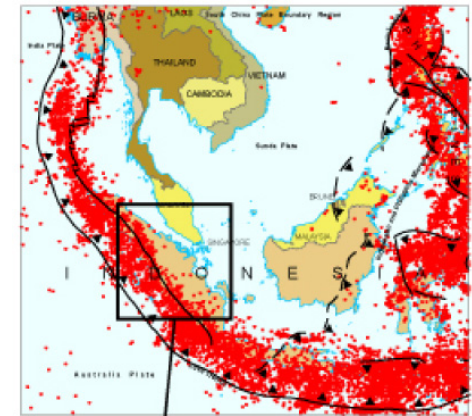

Earthquake

-Seismic issue not a major design consideration

Soil and Foundation

- Irregular bedrock beneath site.

- Perimeter diaphragm walls 2'-6" thk.

- Underground forest of friction piles providing greater distribution of the towers' weight :solution

- Two raft foundations, 15' thick, containing 13,000 cum of concrete.

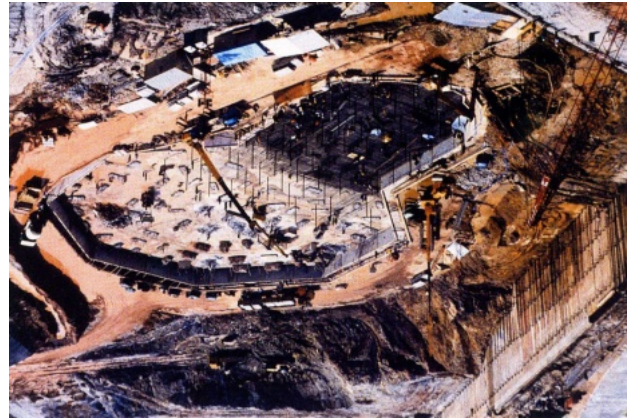

- 300,000 metric ton of each tower spread over concrete slab or mat anchored to soil, not bed rock.

- The towers rest on RCC foundation mat poured over piles.

- 208 barrette piles, rectangular 9ft x 4ft, 197ft to 380ft - control settling.

Construction Process

- Cast in place concrete core walls, perimeter columns and beams use eight sizes and three concrete mixes to optimize size, strength, stiffness and cost.

- Perimeter columns varying in diameter and concrete strength rise, upward and step back to create tapered tower tops.

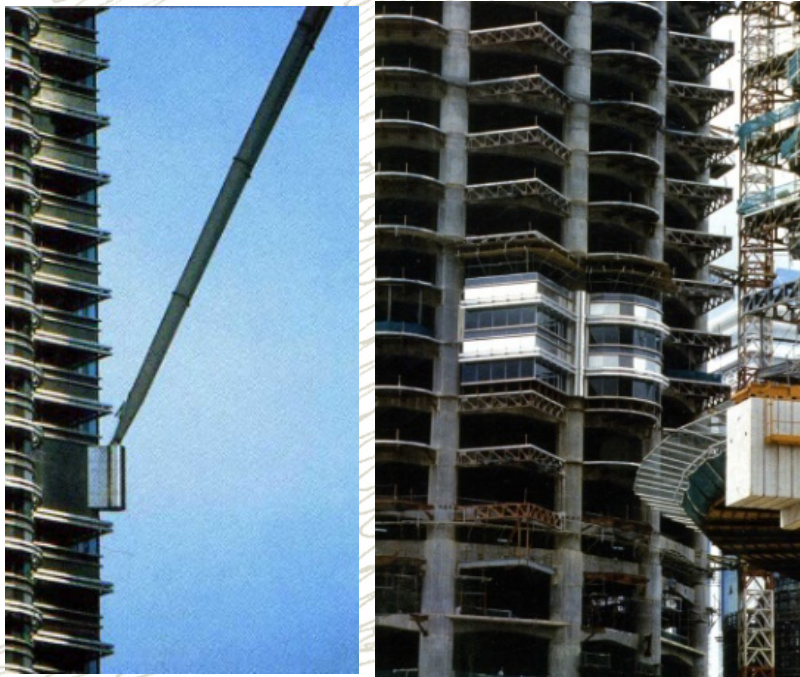



- Concrete outriggers between 38th and 40th floors connect the core to the perimeter columns increasing stiffness and resistance to lateral loads.

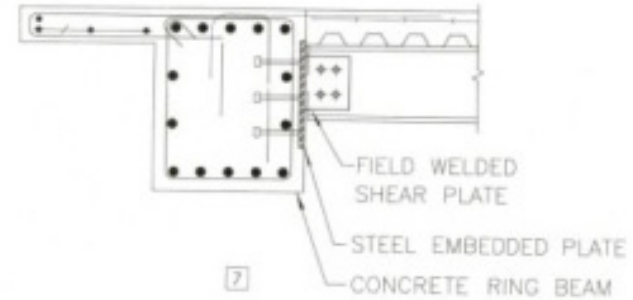

- Steel wide-flange beams provide long spans and fast erection between the concrete core and ring beams.

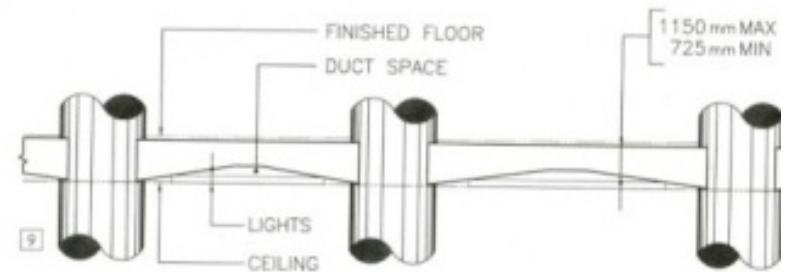

8 The haunched or "bow tie" concrete ring beams

The Sky Bridge

-Designed to function as a building exit in emergencies.

-Shallow girder system for the walkway, supported at mid-span by a three-hinged arch.

-Inverted 'v' shape, 3-pinned arch supports the bridge in the centre accommodating all movements while maintaining it equidistant from both towers.

-The Bridge relies on the towers for gravity and lateral support, but **allows them to move freely**. This avoids the potentially damaging forces that can result when trying to restrain large moving buildings.

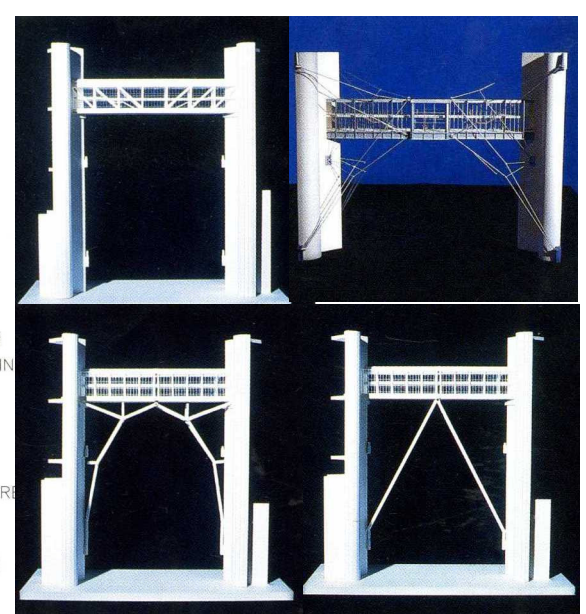
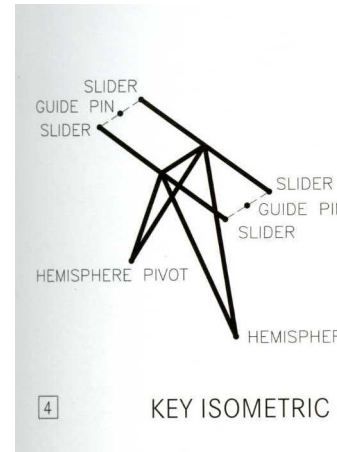

The Sky Bridge

-Each arch leg spins from a single spherical bearing allowing rotation in all axes as tower move.

-Wind forces are important design considerations.

-- Three tuned mass dampers in each sloping leg between the 34th and 35th floors reduce wind-excited leg vibrations, mitigating movements and avoiding metal fatigue.

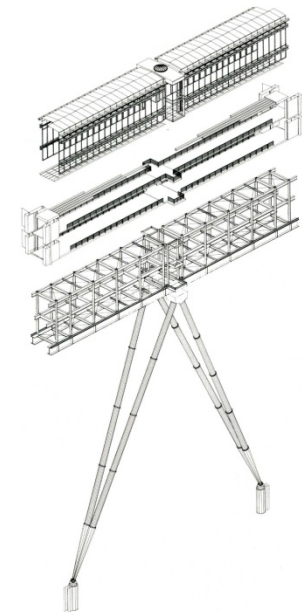
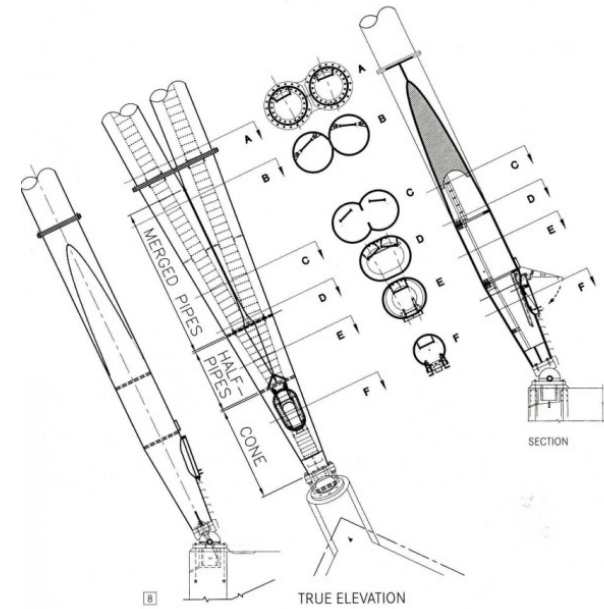
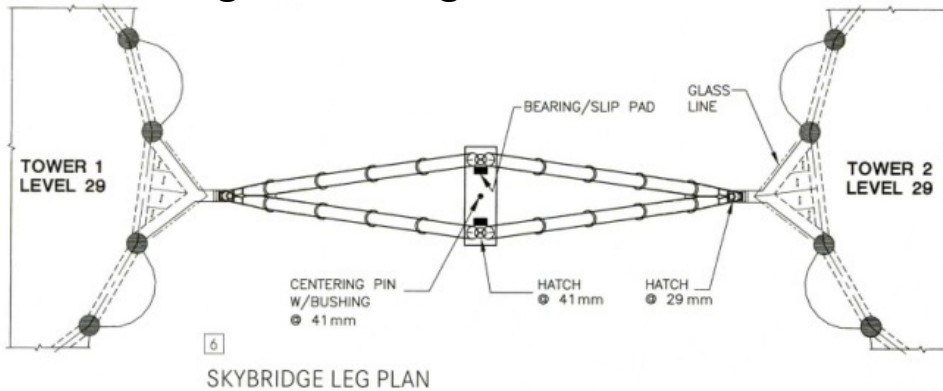

Gravity Loads

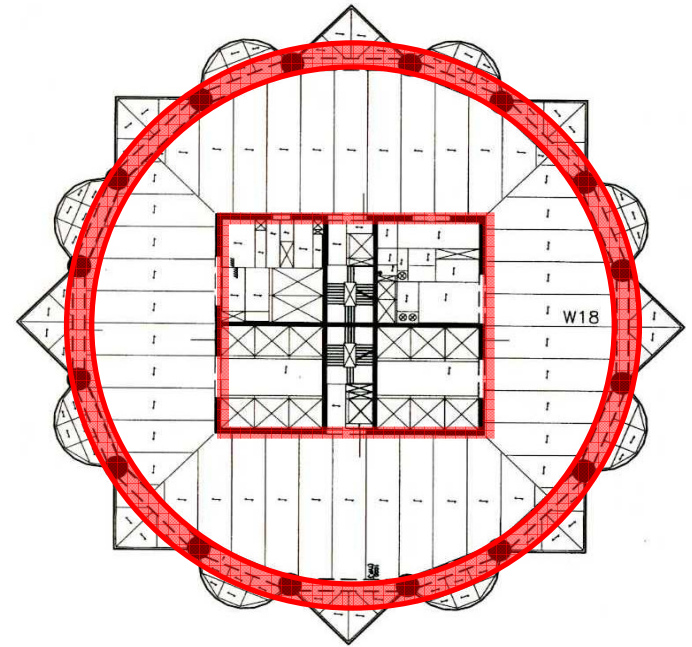
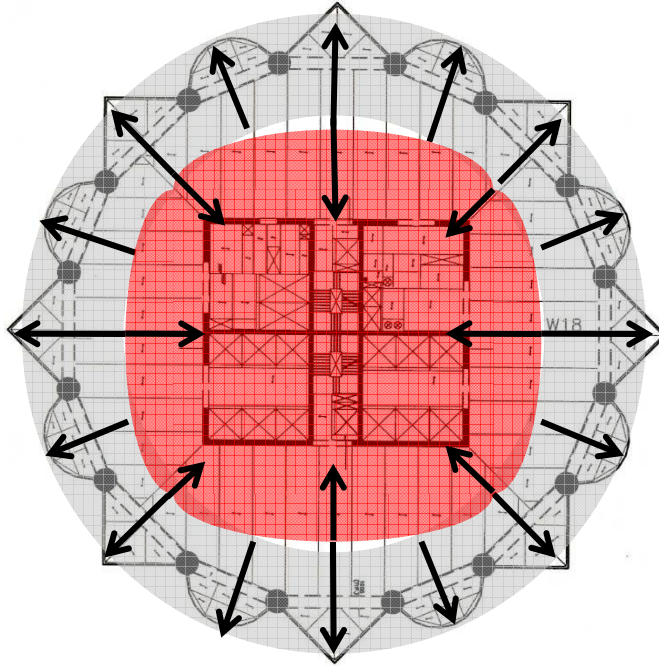

Lateral Loads

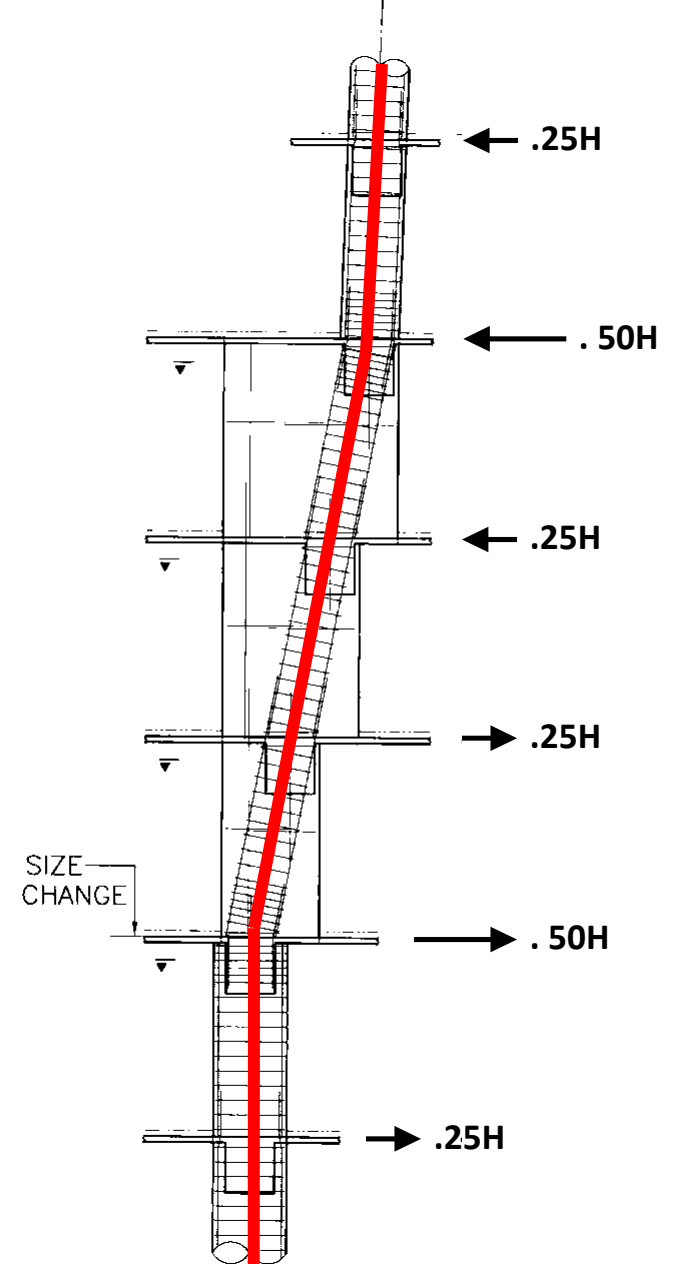
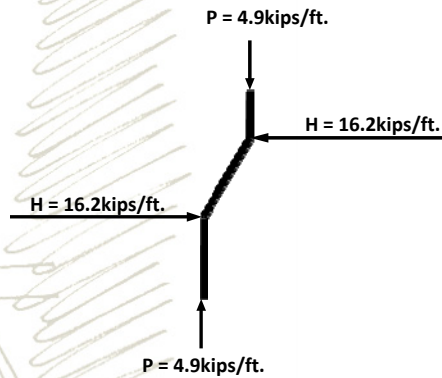

5

Arch Action

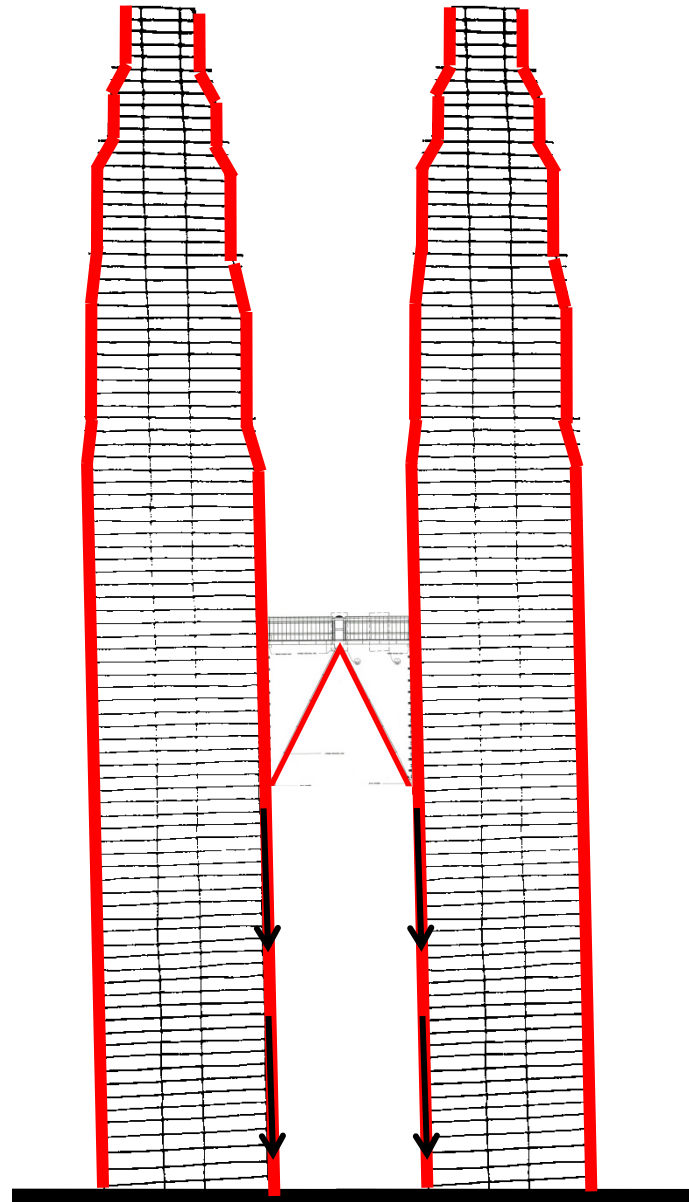
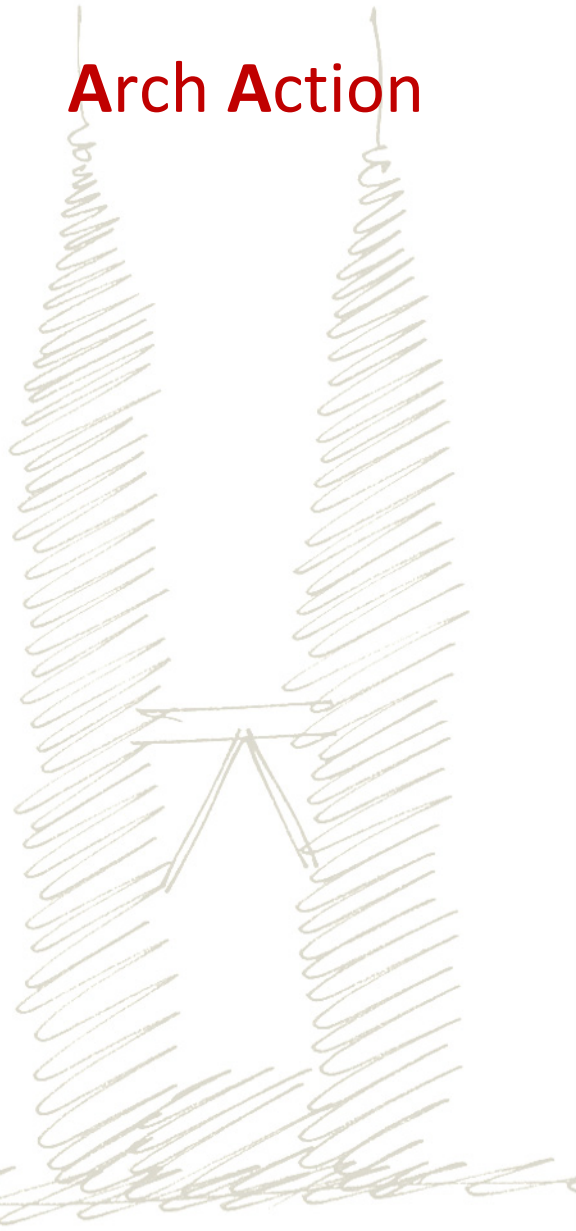

Multiframe 4D Analysis

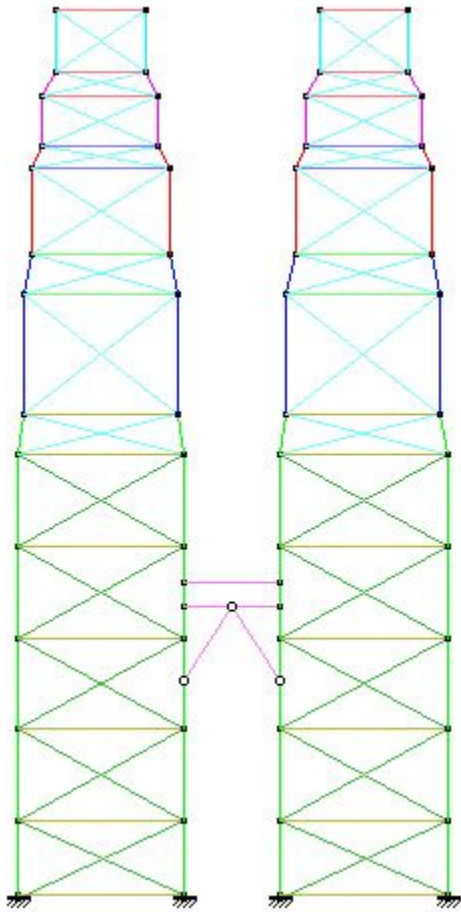

Frame Diagram

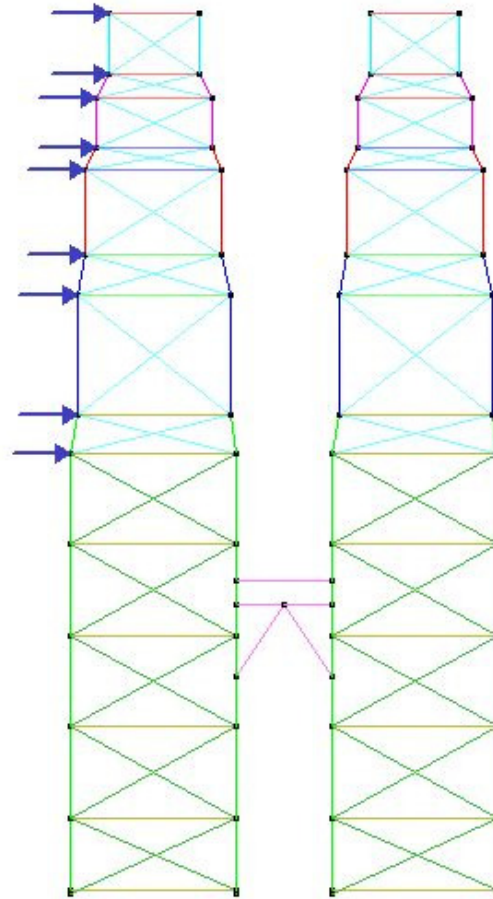

Lateral load Diagram

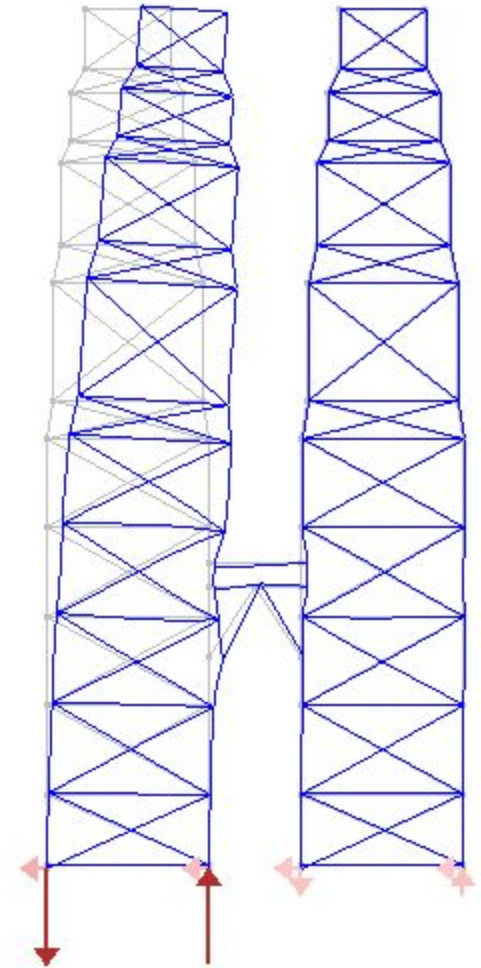

Deflection Diagram

Multiframe 4D Analysis

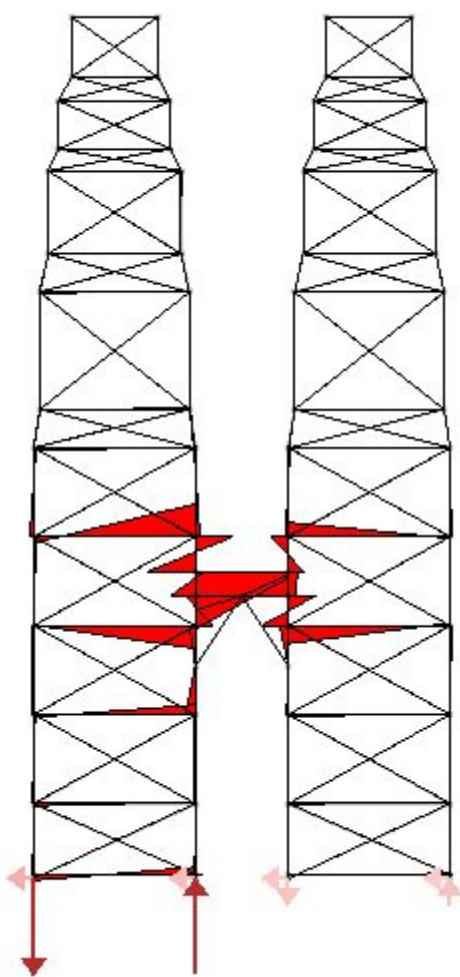

Bending Moment Diagram

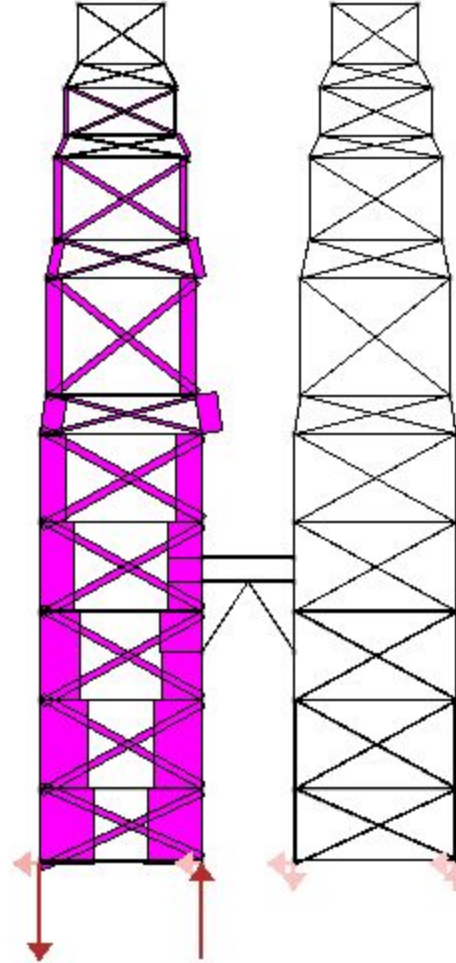

Load Diagram

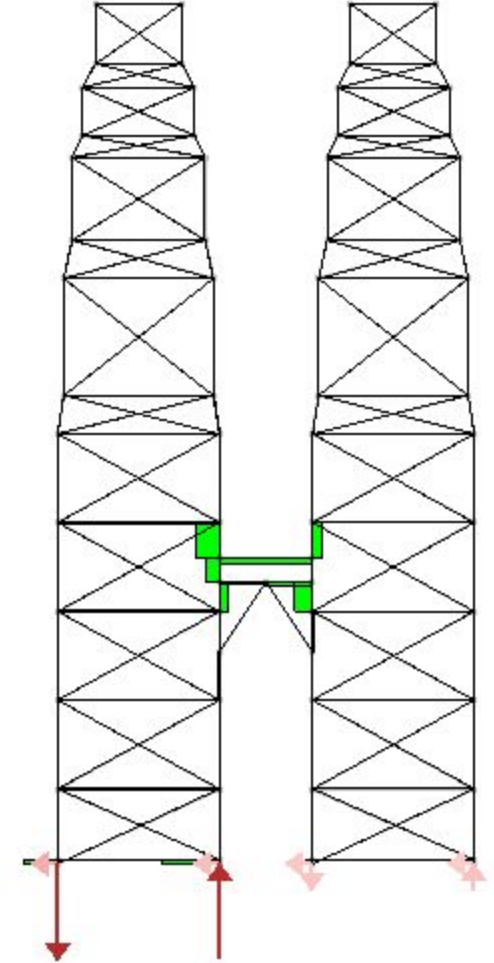

Shear Diagram

Bibliography:

Books:

Petronas towers by Caesar Pelli and Michael J Crosbie;
Wiley Academy, 2001

Expressing structure by Virginia Fairweather;
Birkhauser - Publishers for architecture, 2004

Websites:

<http://www.pcparch.com/flash.cfm> - official website of Pelli Clarke and Pelli architects.

http://en.wikipedia.org/wiki/Petronas_Twin_Towers - wikipedia, an online encyclopedia.

http://www.archnet.org/library/downloader/file/1403/file_body/FLS1235.pdf. Documentation of the development owned by Archnet.

<http://www.usc.edu/dept/architecture/mbs/struct/Arch613/projects/petronas%20towers-pdf.pdf> .
UNIVERSITY OF SOUTHERN CALIFORNIA, Los Angeles, Master of Building Science Program, ARCH 613 :
Structures Research. Student work done by Jonathan Tedjakusuma,
Gautam R Shenoy, Fall 2001 for Term Project

Credits:

3D model was downloaded from Google's open source model collection and was originally uploaded by: "jw_n_mo" on August 23, 2006

Thank You!

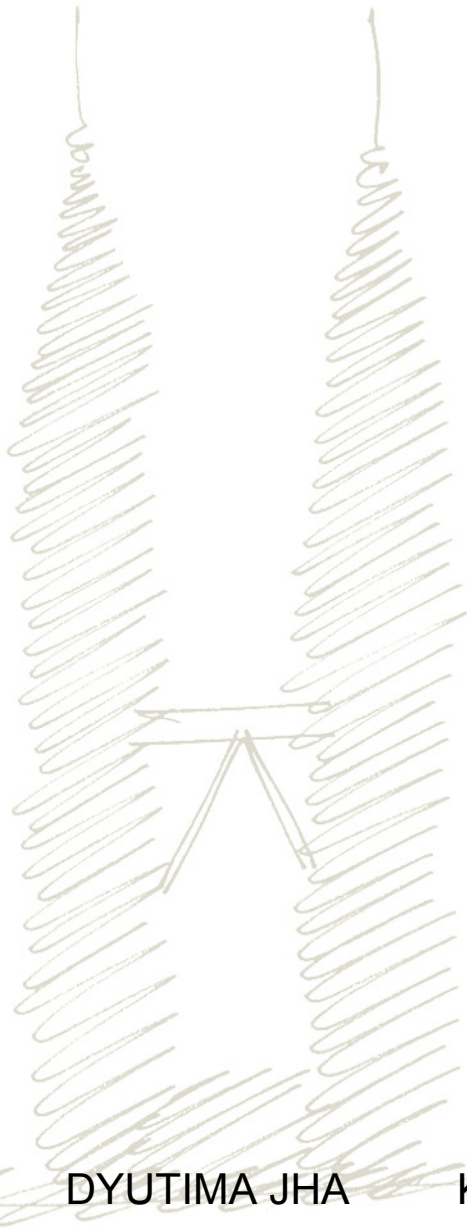

DYUTIMA JHA

KAUSHIK GANESH

NANDITA RAGHU

SHRUTI GUPTA

A STRUCTURAL CASE STUDY PETRONAS TOWERS
ARCH 631 Prof. Anne Nichols