

Guangzhou Opera House

Erin You

Haifeng Pan

Jing Zhao

Tan Zheng

Yuan Ma

Overview (Introduction)

Zaha Hadid's design won the first prize and was confirmed as the practical one which will become an icon for the Guangzhou City and even accelerate the urbanization of new developing downtown.

- Background Information
- Design Review
- Principle Structure System
- Structure Area Division
- Interior Space
- Auditorium
- The Envelope System
- Underground Structure and Foundation
- Detail
- Conclusion

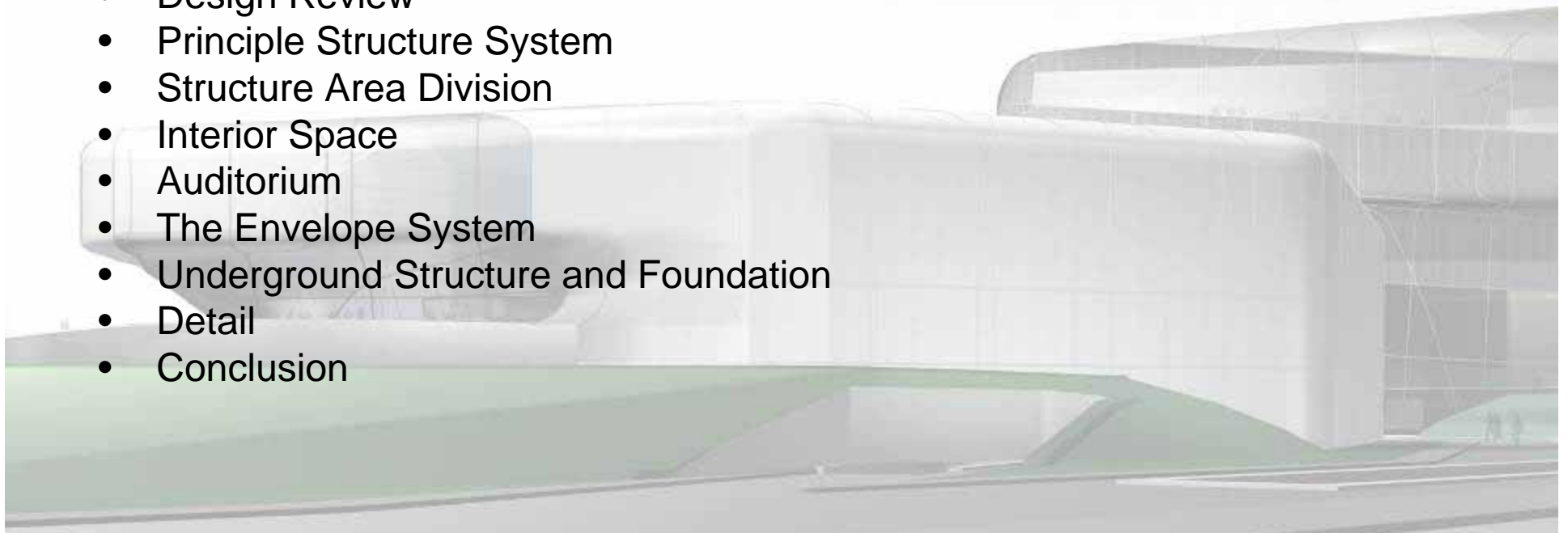

Guangzhou Opera House (Background)

- The third biggest opera architecture in China
- One opera hall (includes main stage, side stage, and back stage) 1,800 seats
- One multiple-purpose hall with 400 seats
- Foyer, art gallery, restaurant, garage
- 70,000 square meters (30,000 square meters underground)
- Total construction investment of 200 million dollars

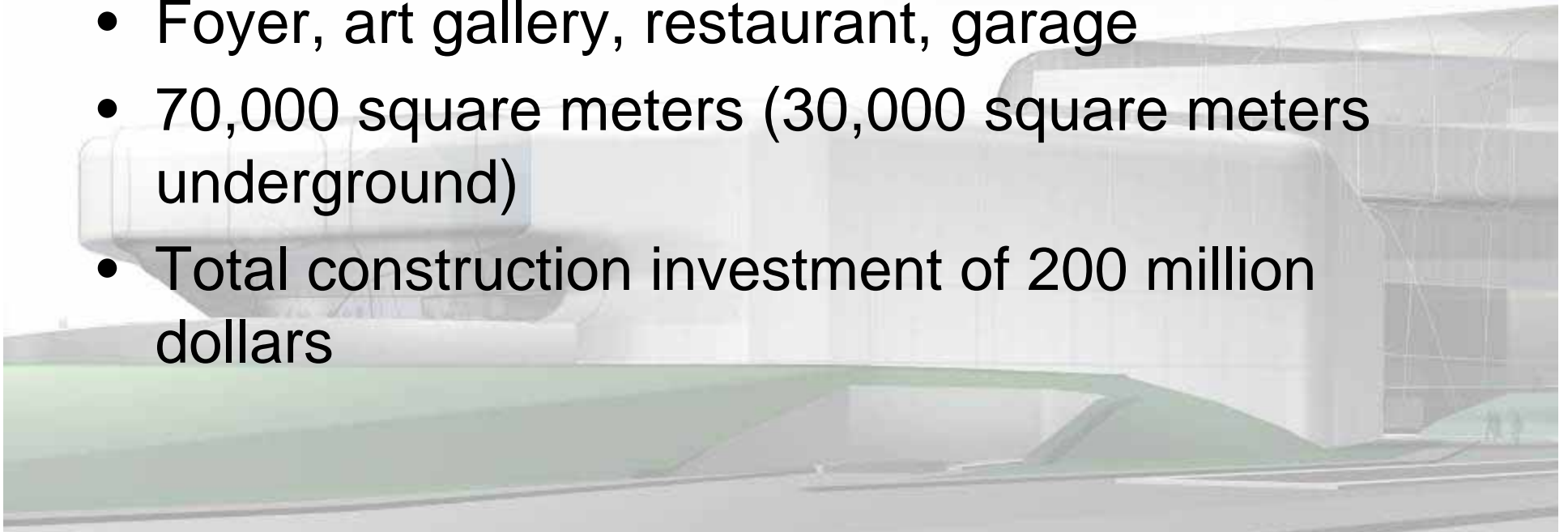

The Architect — Zaha Hadid (Background)

- The first woman to win the Pritzker Prize for Architecture
- ZAHA HADID has defined a radically new approach to architecture by creating buildings
- Multiple perspective points and fragmented geometry to evoke the chaos of modern life.



Design Review

- Create a new focal point in Guangzhou city
- Located downstream of Pearl River
- Its unique twin boulder design enhances urban function with open access to the riverside and dock areas
- Create a new dialogue with the emerging new town
- The sheltered area formed in its intersection has been designed to accommodate outdoor activities to complement its primary role as a world stage for the performing arts

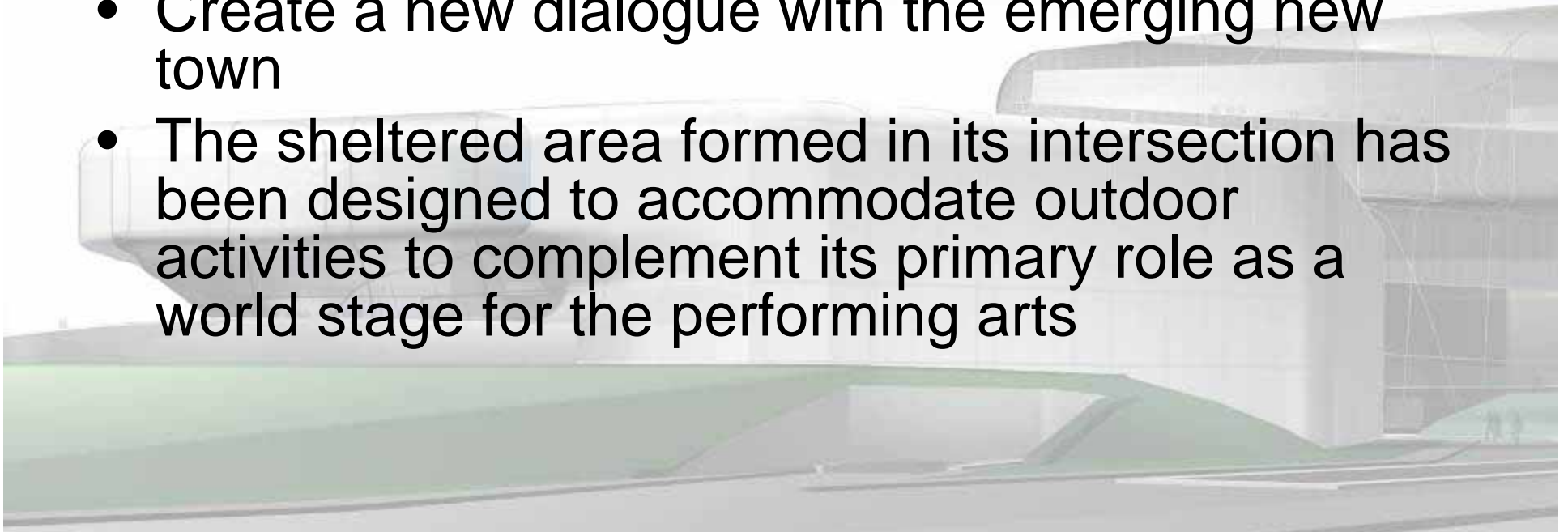



0.00 Level

5.00m Level Plan

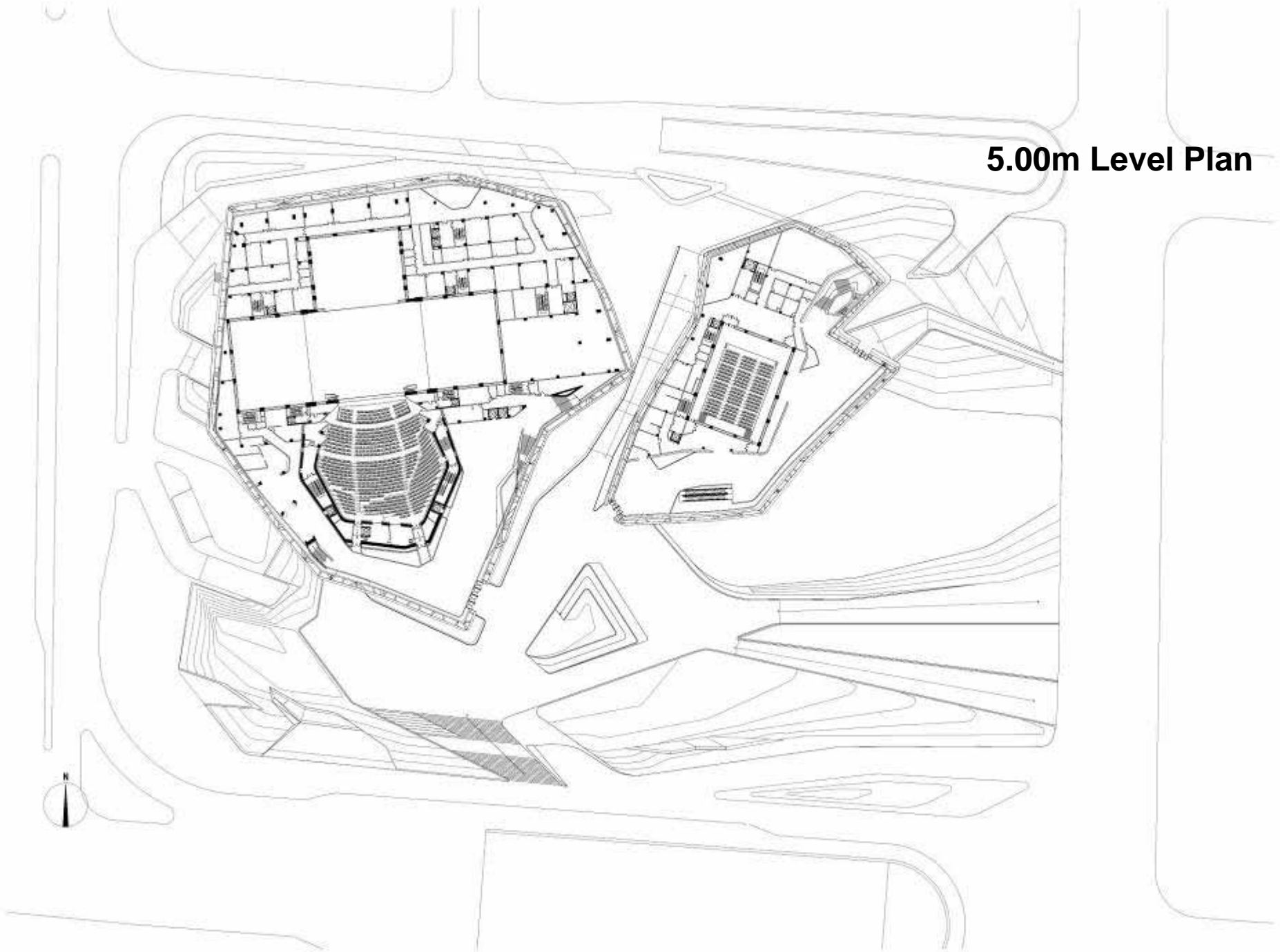

11.00m Level Plan

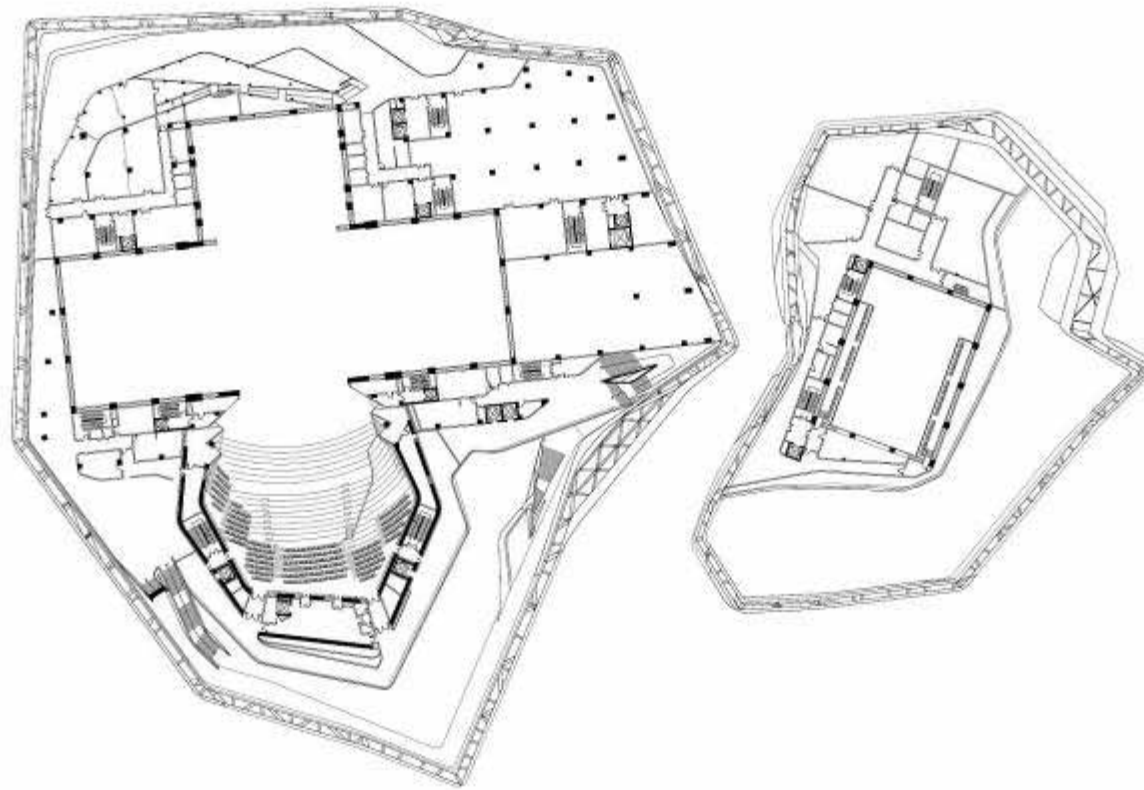

16.00m Level Plan

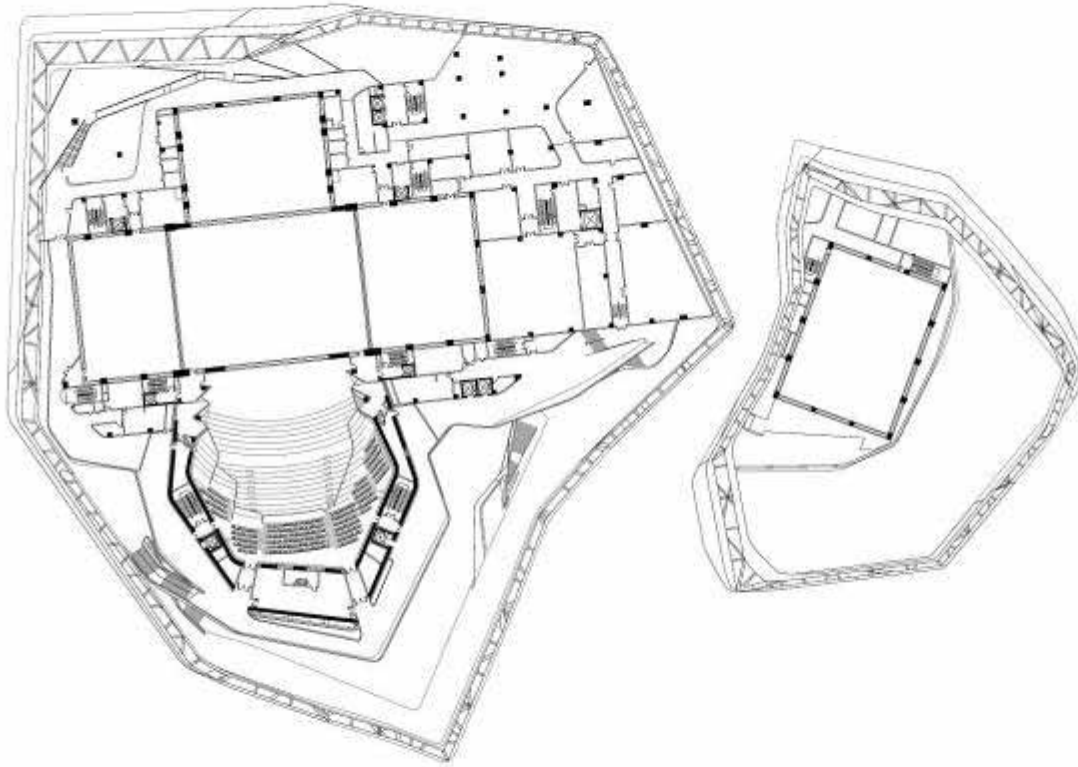

20.00m Level Plan

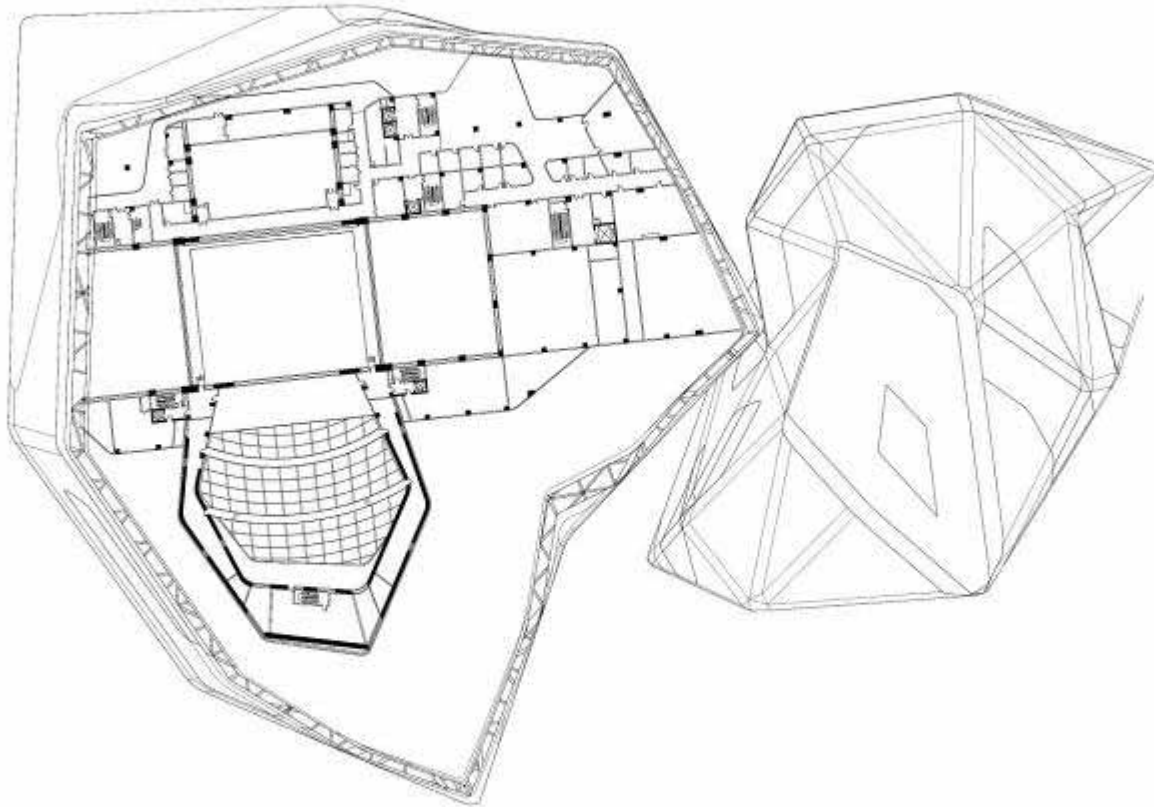

25.00m Level Plan

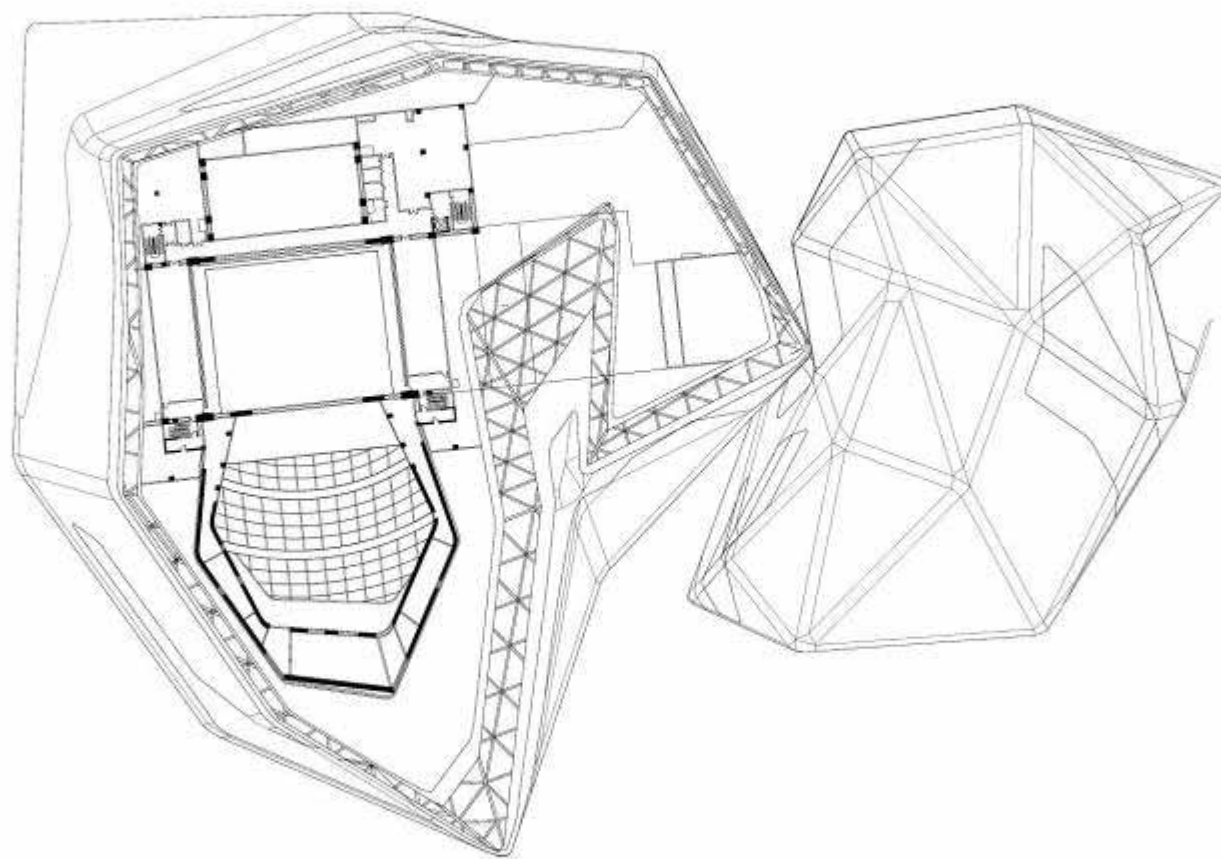

29.00m Level Plan

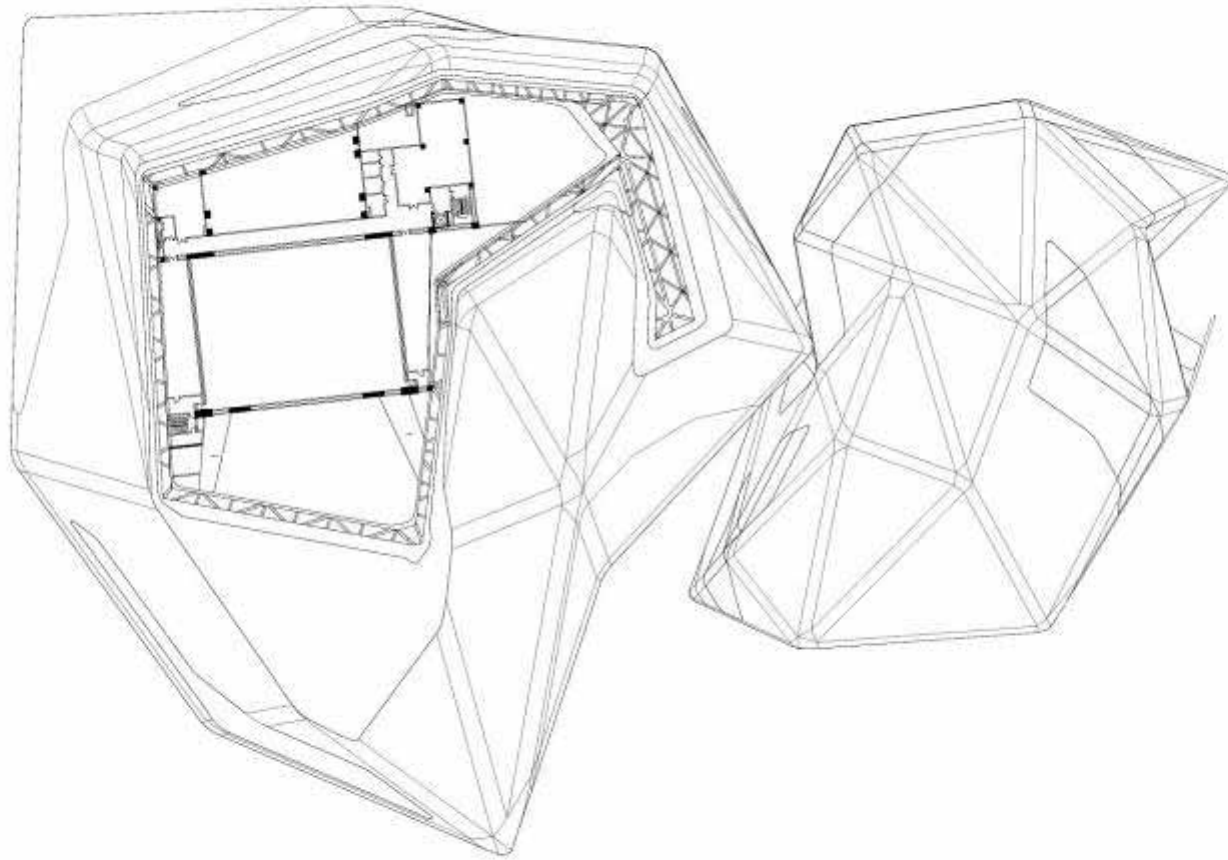

Roof Plan

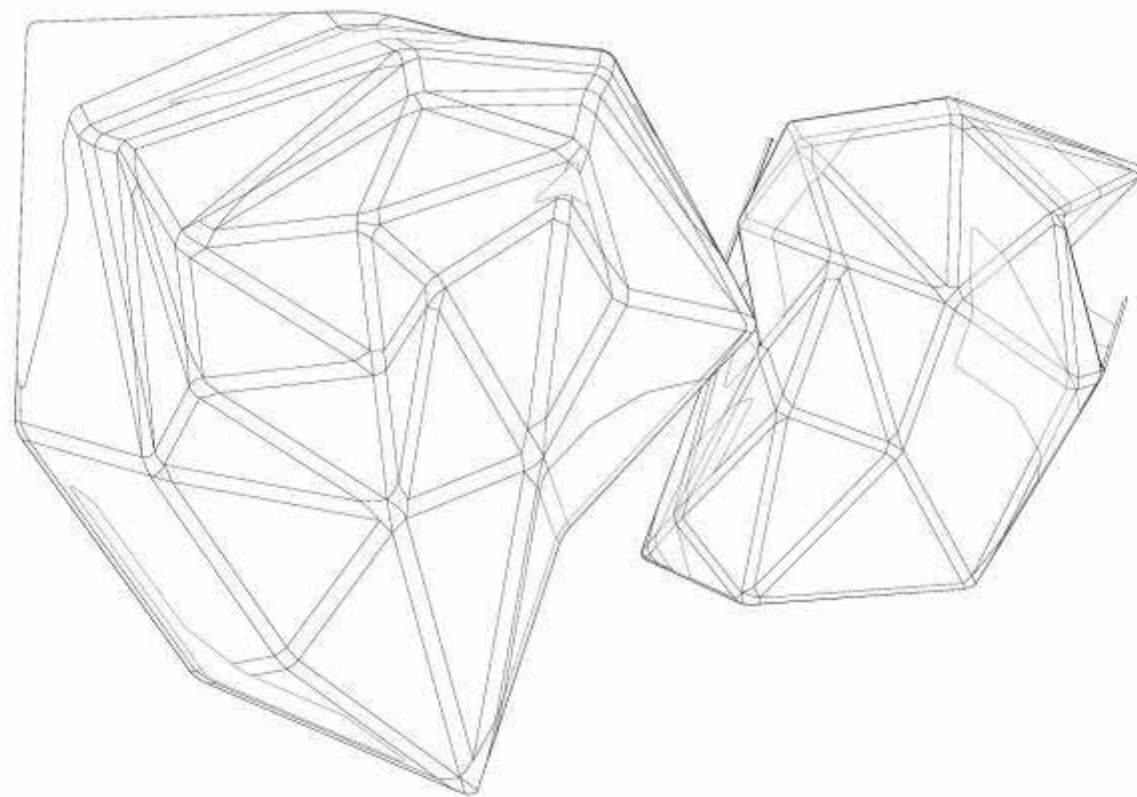

Section A

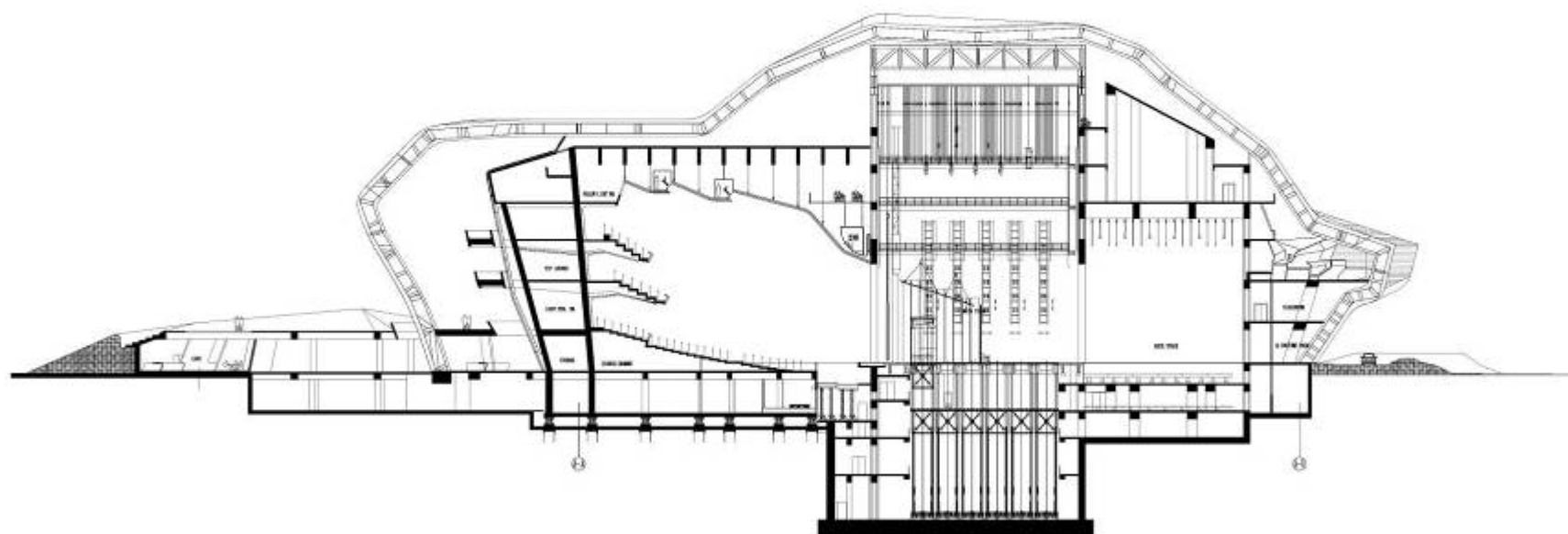

Section B

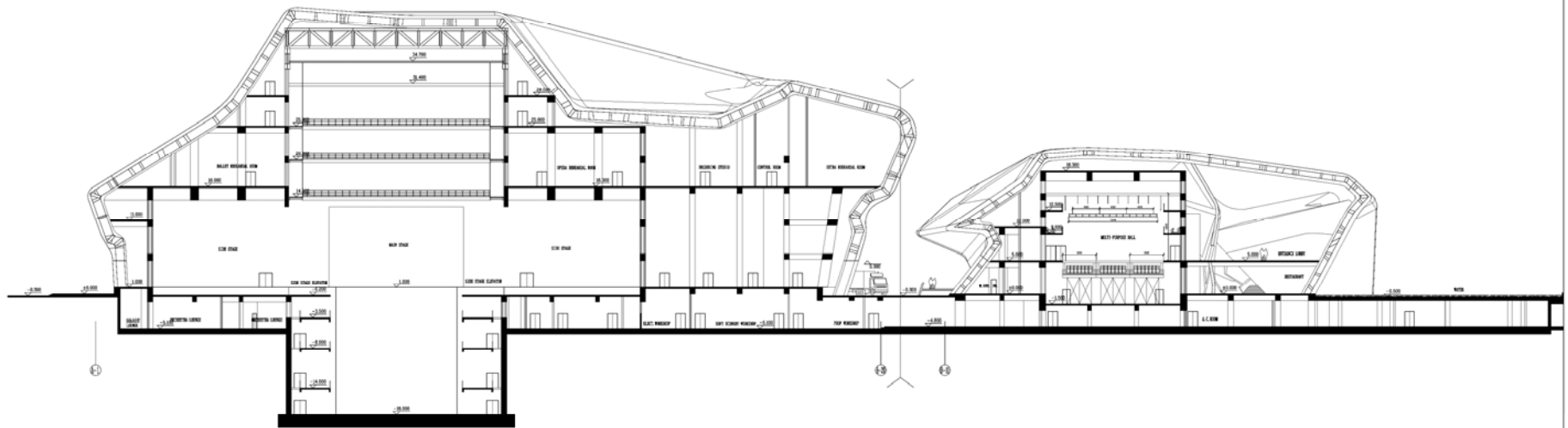

Principal Structure System

The building above ground includes four independent structural units:

- No.1 Opera Hall Without Auditorium
- No.2 Auditorium
- No.3 Multi-Purpose Hall
- No.4 +4.85m Main Entrance Plaza

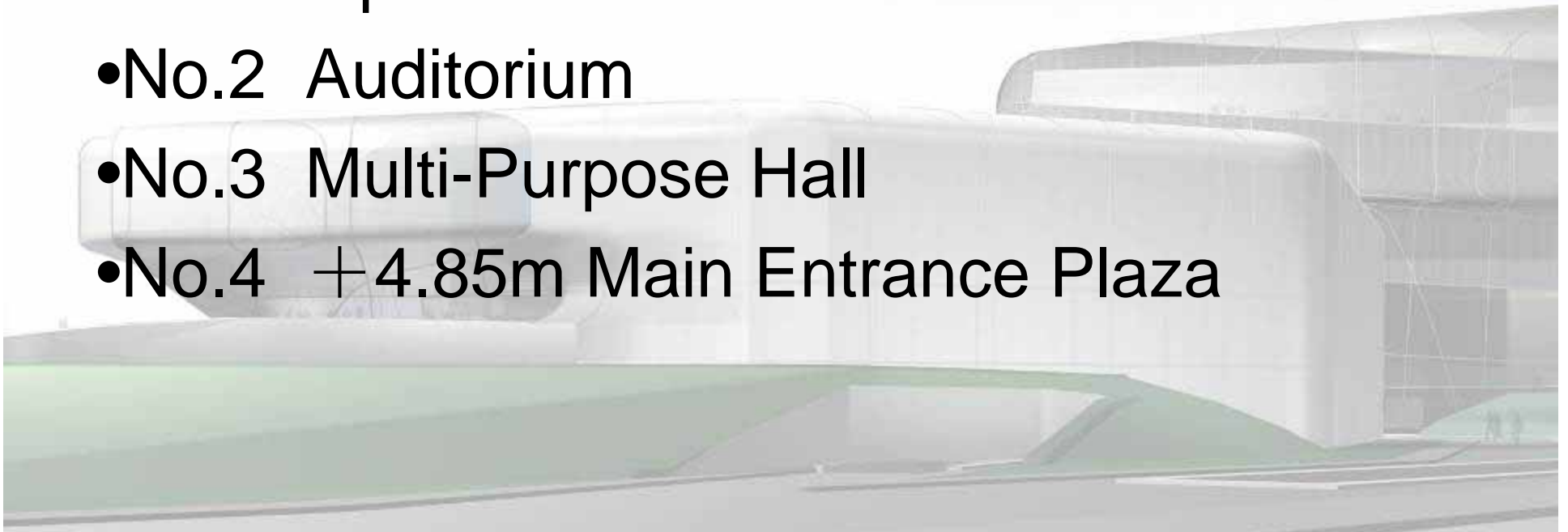

Structure Unit Division

- No.1, 3, 4 units connected underground
- Above the +0.00 level separated
- No.2 unit is the auditorium with entirely floating floors and walls
- Be separated
- Be supported by the steel spring device

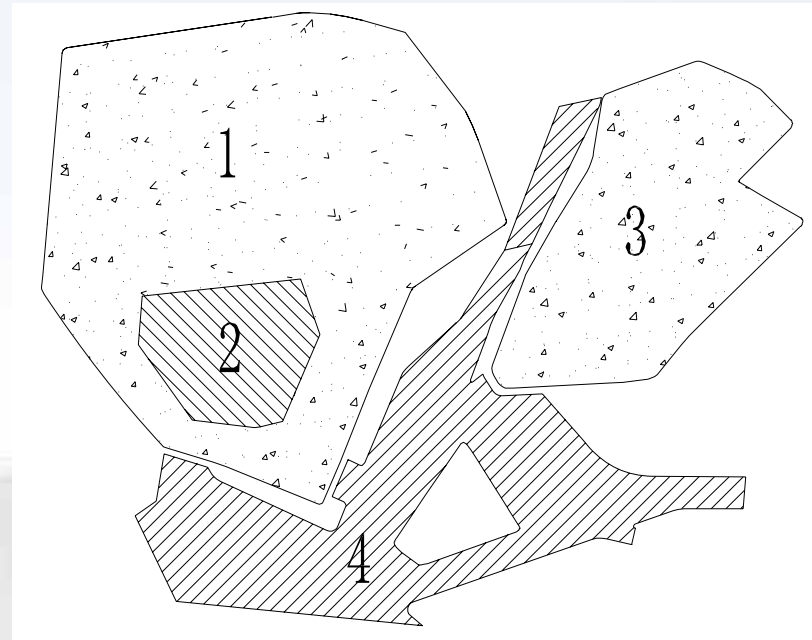

Disengagement of Envelope and Interior Space

- Envelope system supported by the reinforced concrete slab at 0.00 level
- Separated
- Opera hall: 6 pinned joints
- Multi-purpose hall: 4 pinned joints
- Pinned joints: limit the deformation **ONLY** in the vertical direction

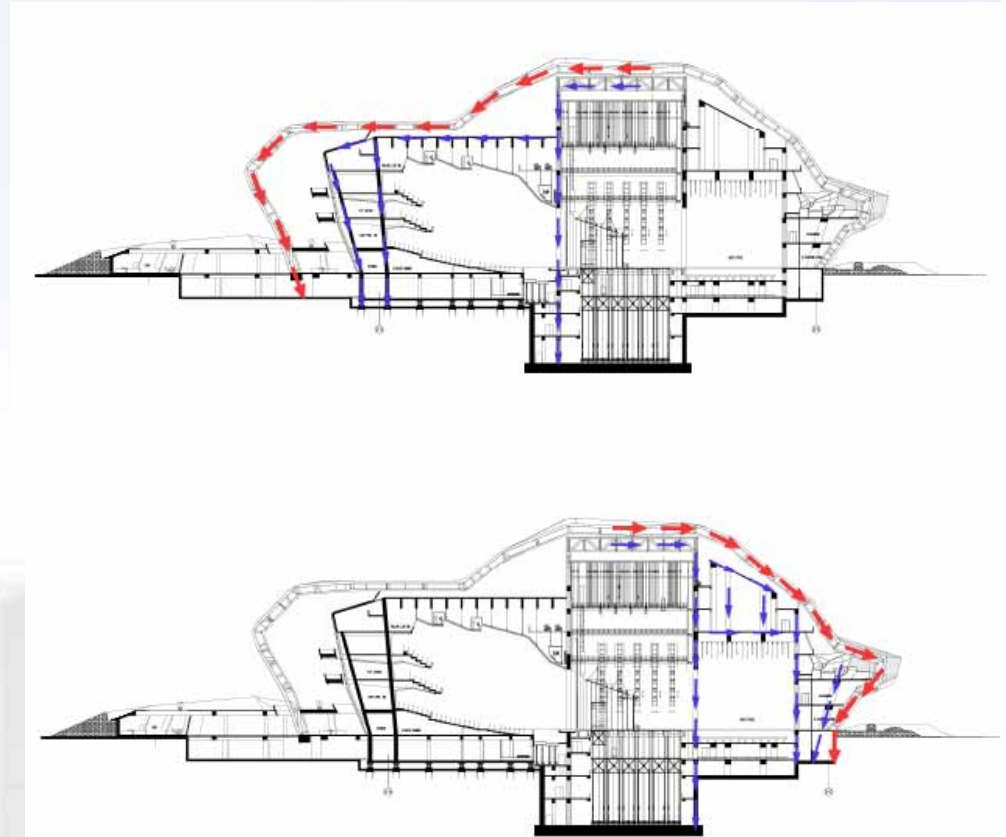

The Envelope System

- Includes Two Parts
- Opera Hall ---The Envelope System of Rigid Frame Structure
- Multi-Purpose Hall ---The Envelope System of Rigid Frame Structure
- Both of them are the integrative Rigid Frame Structure of slabs and curtain walls.

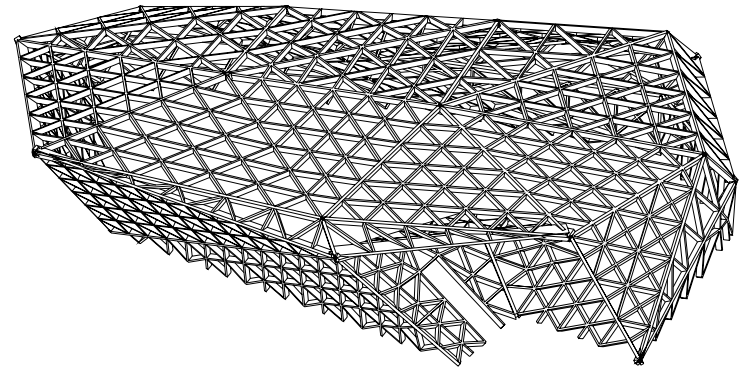
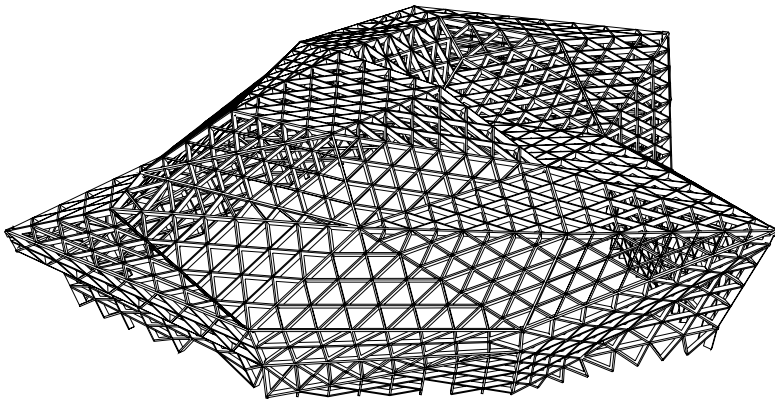

- Deep steel trusses supporting roof, envelope and ancillary equipments.
- Asymmetric Horizontal Forces due to radical ribs to be transformed to the ground via auditorium walls.

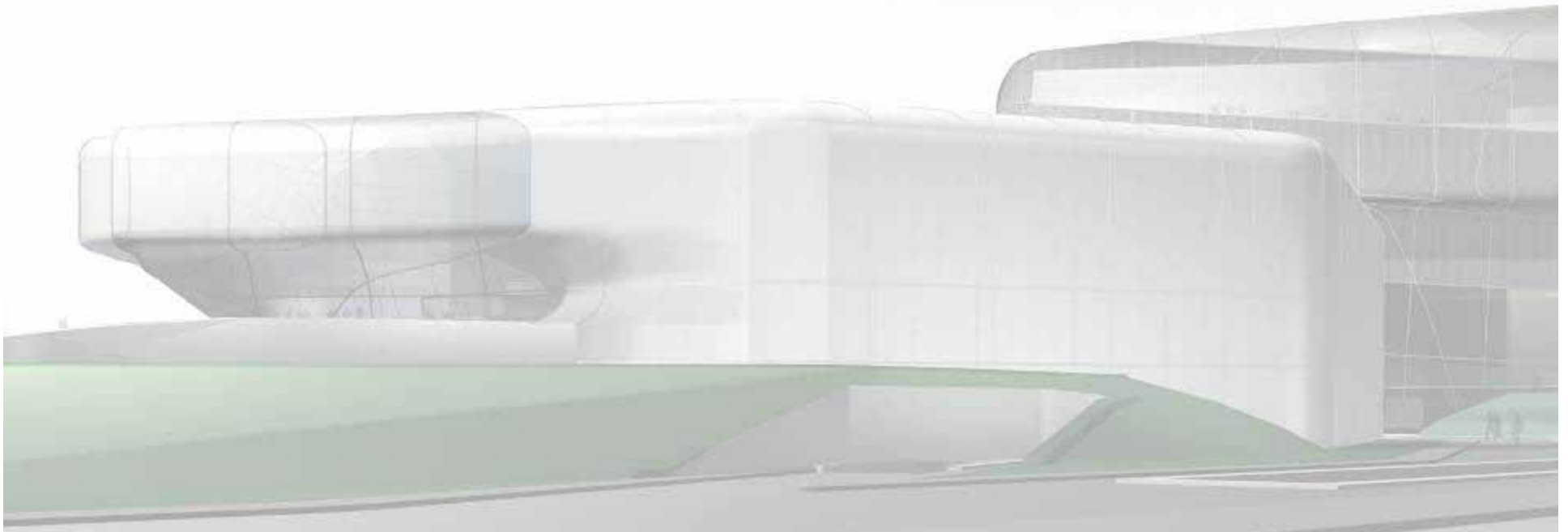

- Lateral Resisting system

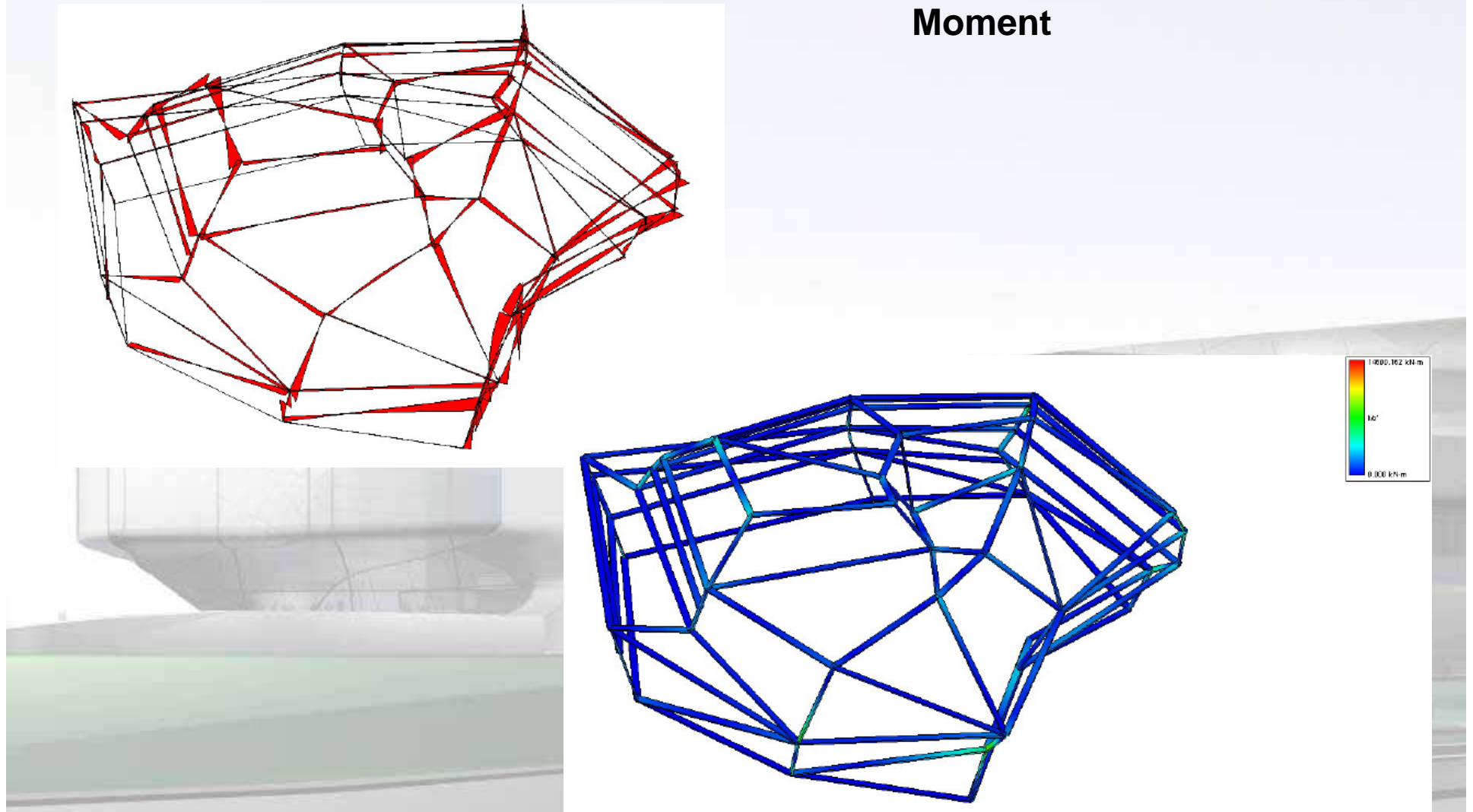

Lateral Resisting system

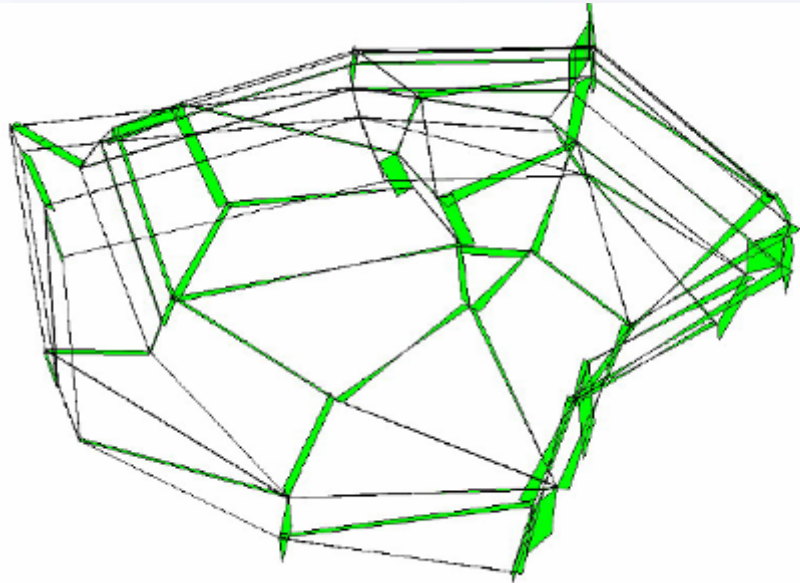

Shear

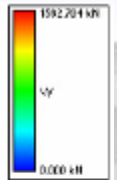
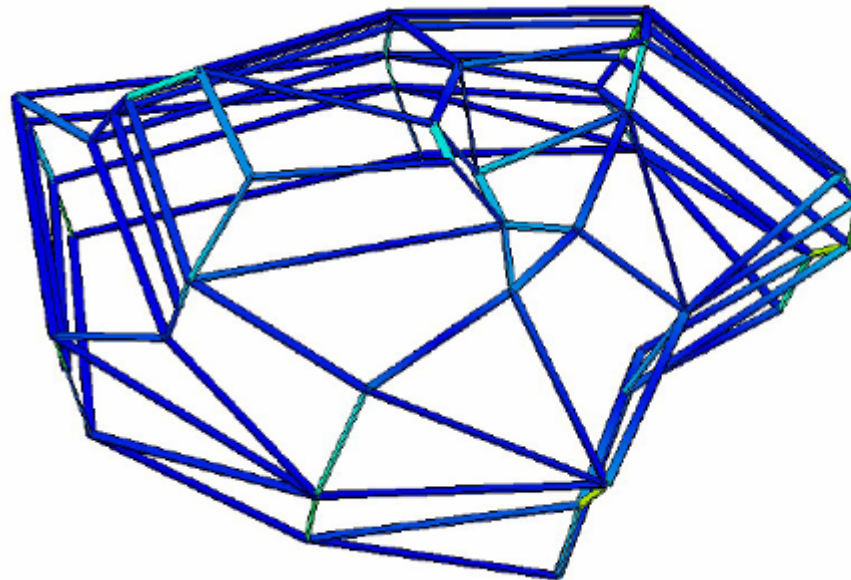
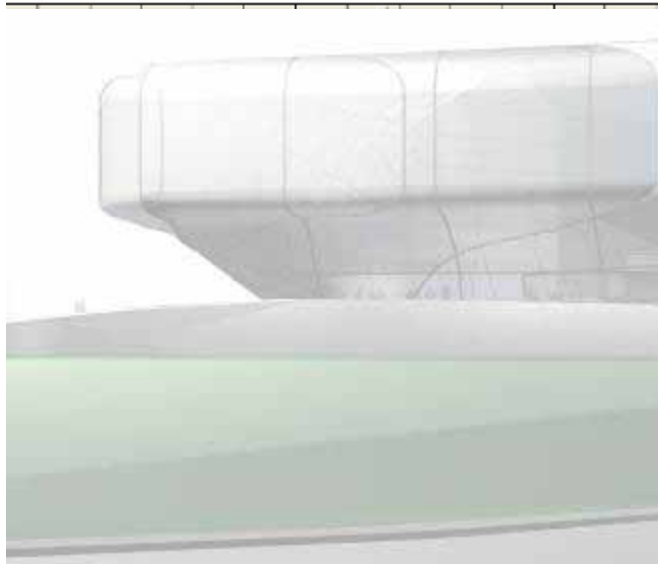

Lateral Resisting system

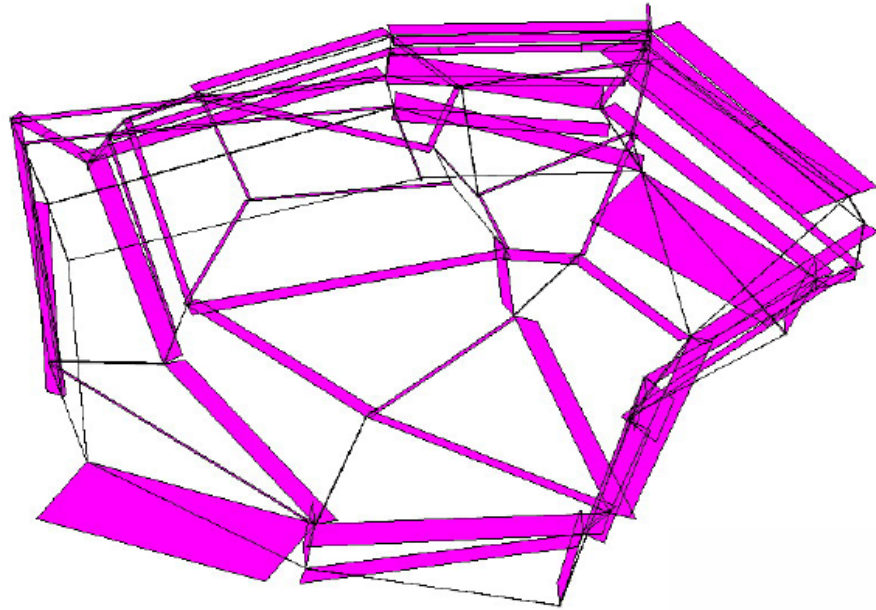

Pressure

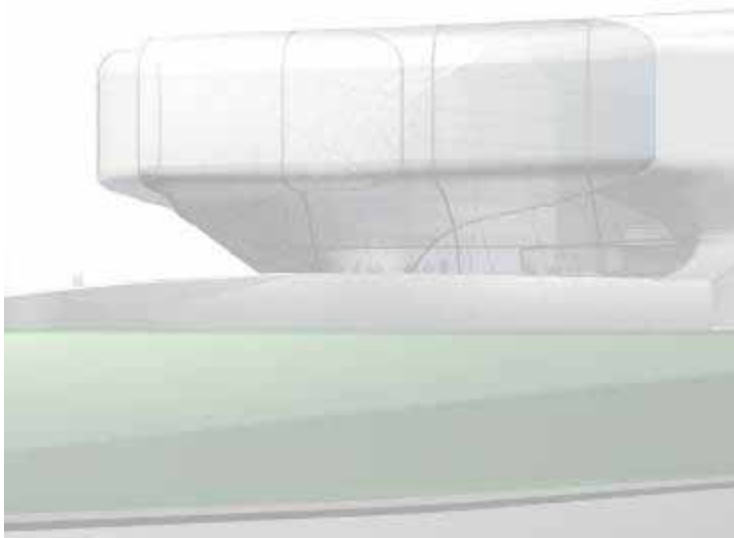
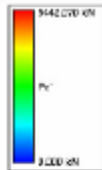
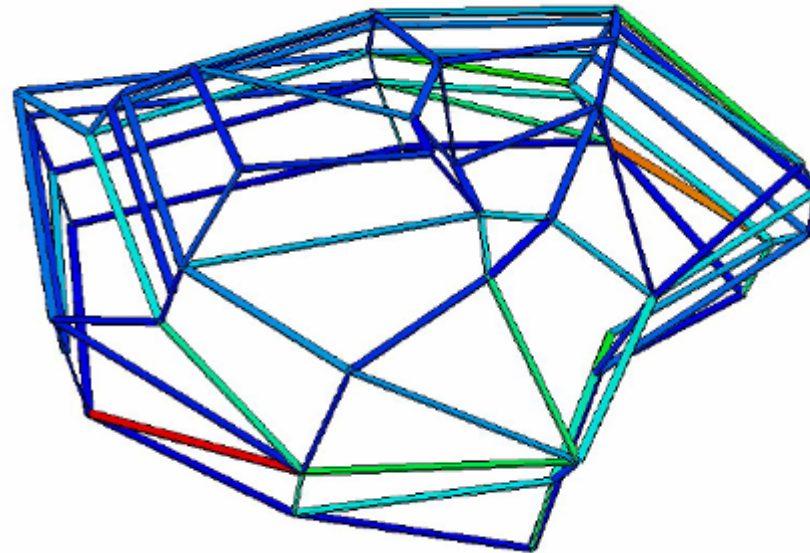

Lateral Resisting system

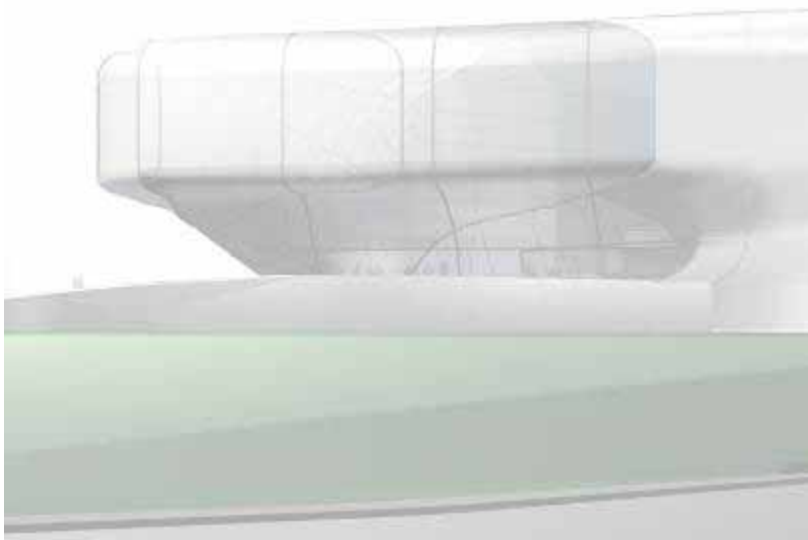
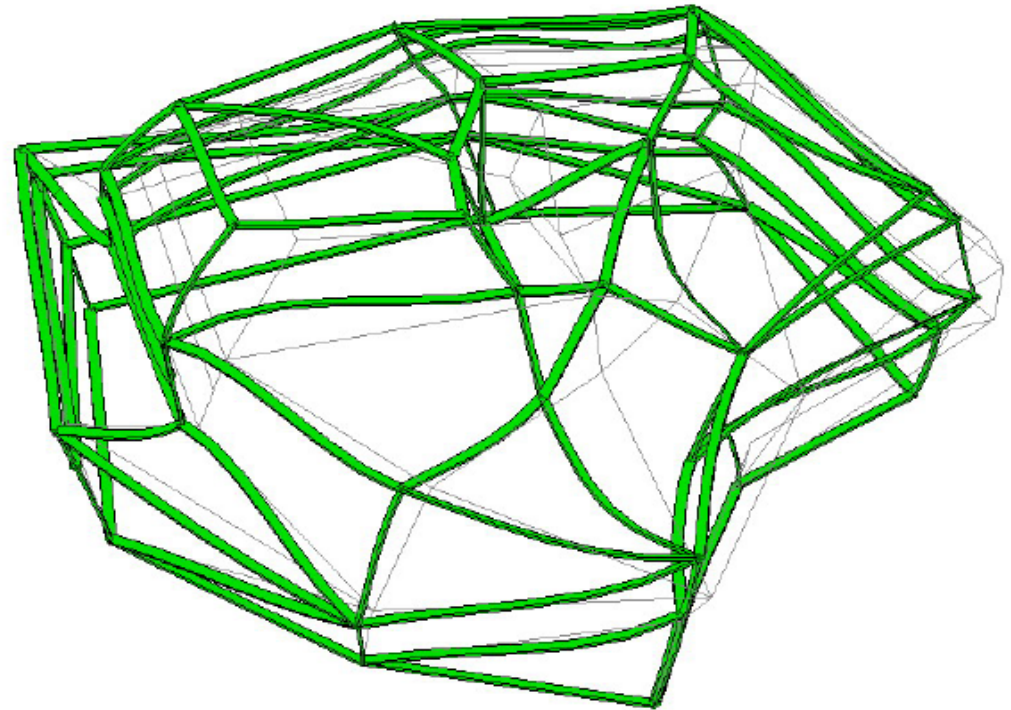
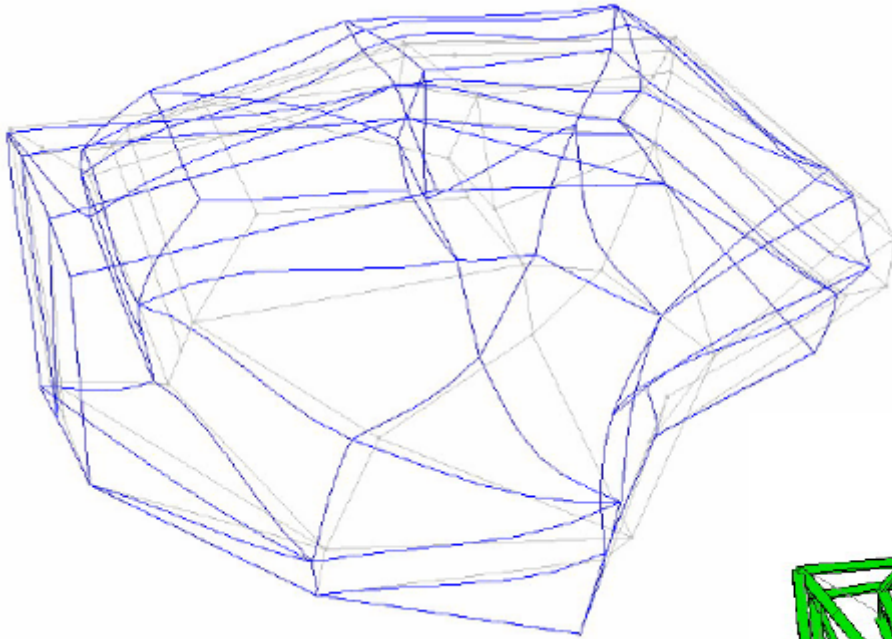

Opera Hall

- Guangzhou Opera House three combinations packs plate grid structure of the bias
- the external envelope supported by the horizontal elements.
- In its internal space, 6 fulcrums are founded at the intersections of the ridges.
- They are connected by the two-direction spherical roller bearing (bi-directional sliding spherical hinge bearing)



- The edges are divided into 8 parts in every plane (some are divided into 4 or 2 parts).
- The members are joined by the welding steel box beam. Rigid joints are formed.
- Girders are placed at the joint line of each face. Beams are located along the edges of the triangle nets.

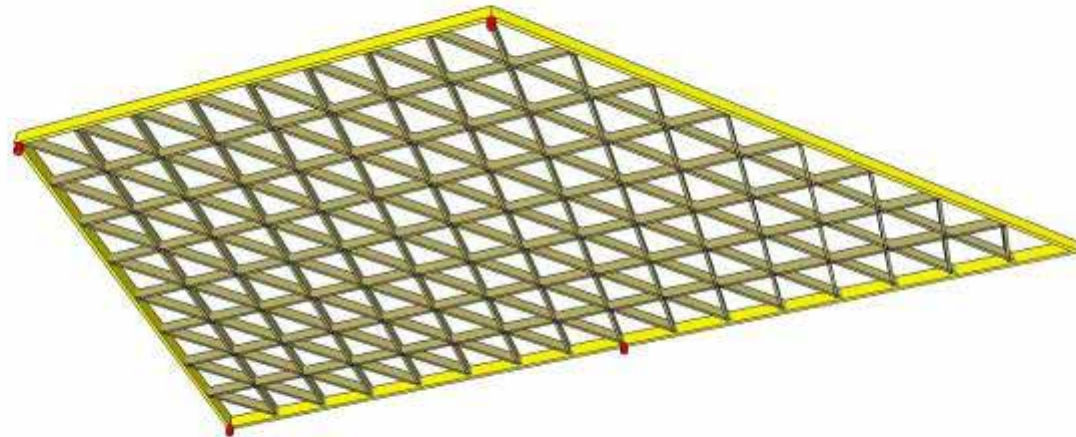

Multi-Purpose Hall

- The external structure of multi-purpose hall three combinations packs plate grid structure of the bias
- The external envelope supported by the horizontal elements.
- Four fulcrums are set in the intersections of the ridges.
- Two-direction sliding spherical seismic-resisting bearing

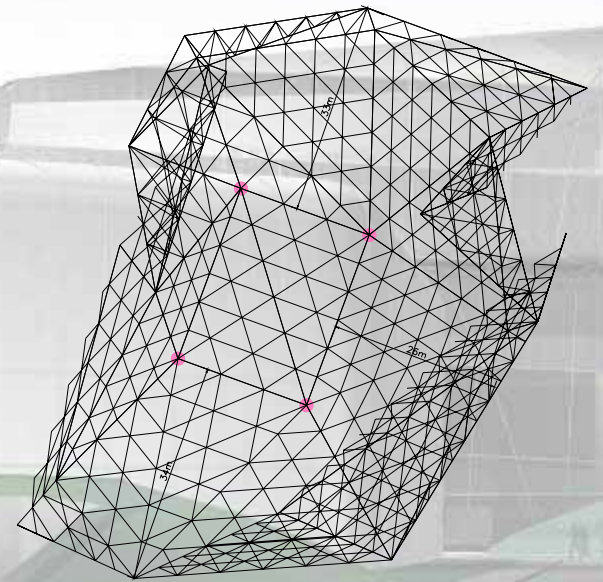

Interior Space

The upper level structure of No.1, 3, 4 units is part of the frame structure with few shear walls.

Characteristic:

The scale of cantilever and move back of each architectural plane are great



- Set up the inclined supporting columns at the position of great cantilevers
- Apply a few of inclined columns and concrete cylinder in foyer



Apply section steel concrete structure

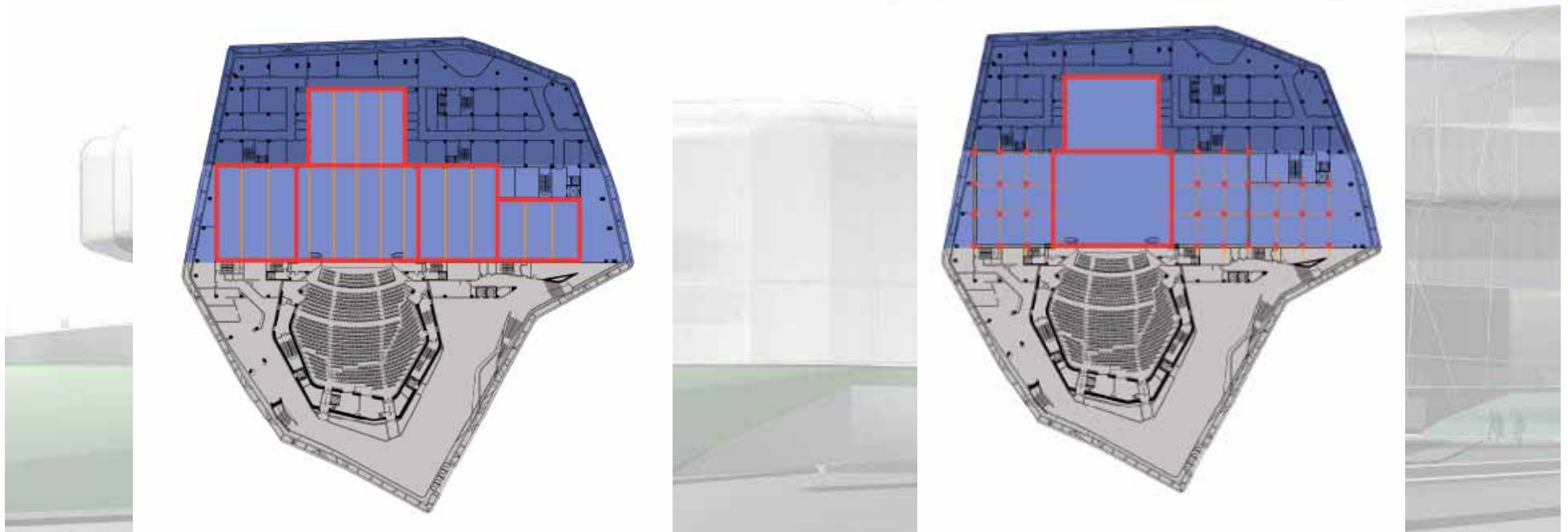

In the slab system, apply two-way reinforced concrete beam and slab system in No.1, 3, 4 units.

Characteristic:

- Long-span slab
- The cantilever whose span surpass 5-meter, such as the cantilever in sky lobby at +11.00m level, should be applied beam system for post-tensioning prestress with bond.
- The frame columns at top level applied the method of linear prestressing tendon arrangement to resist the moment at ends of beams.

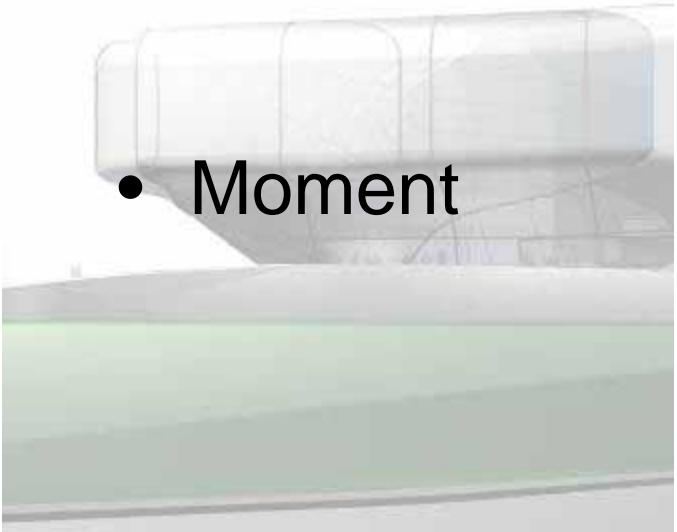
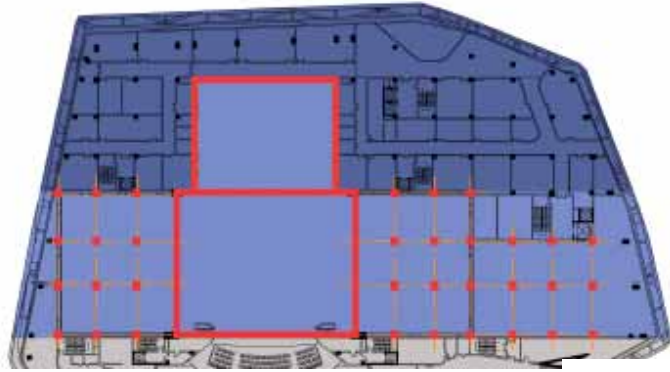
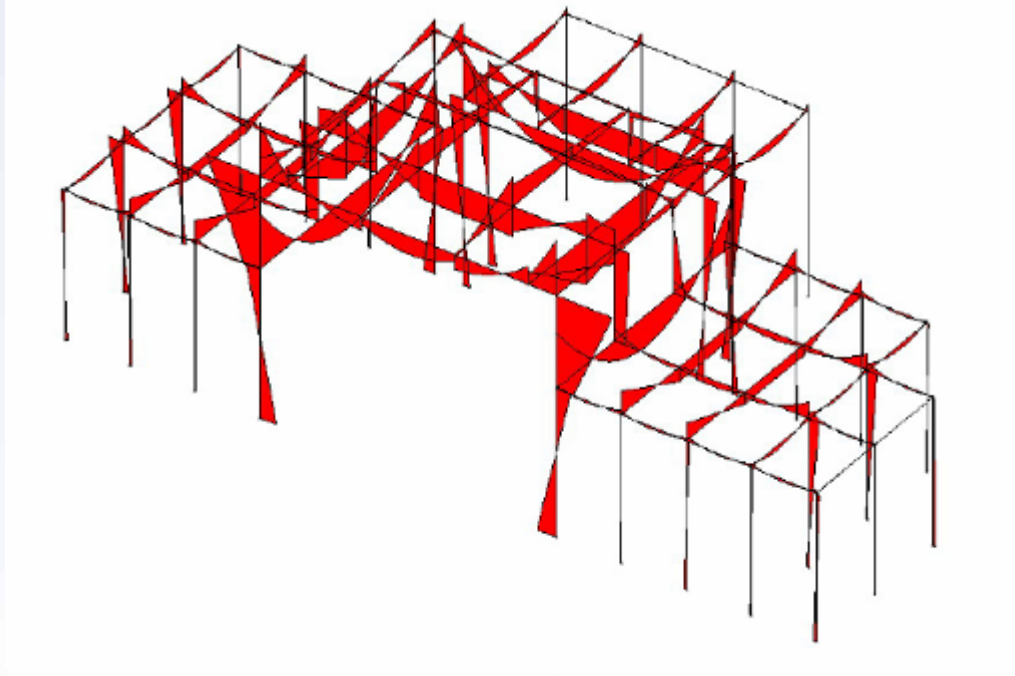

• Moment

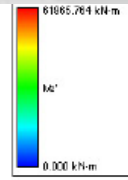
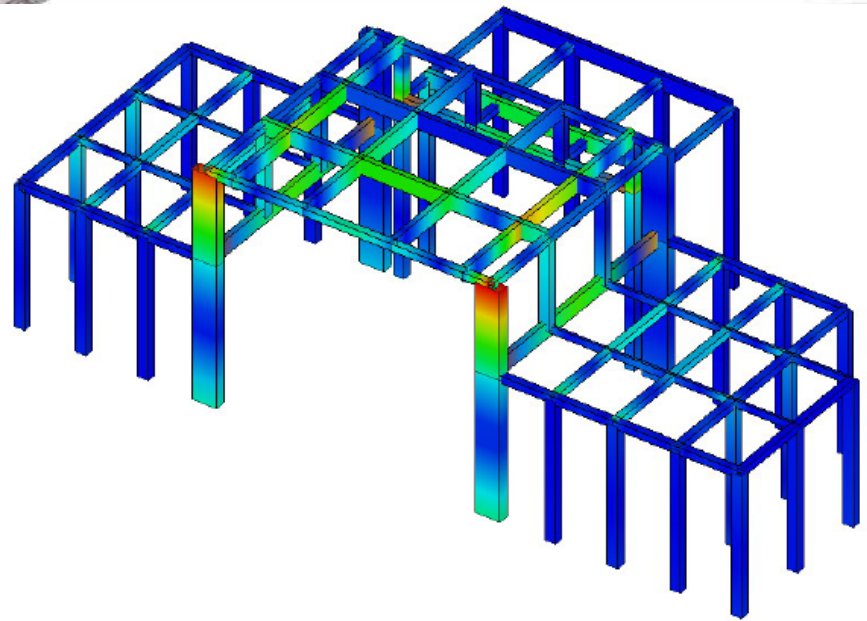

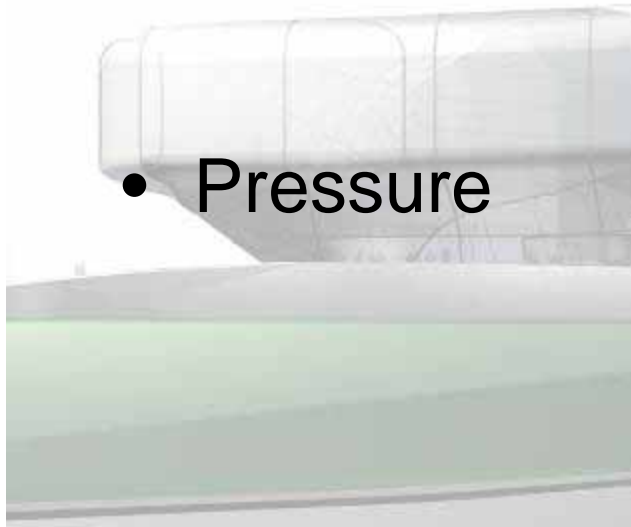
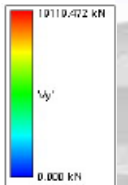
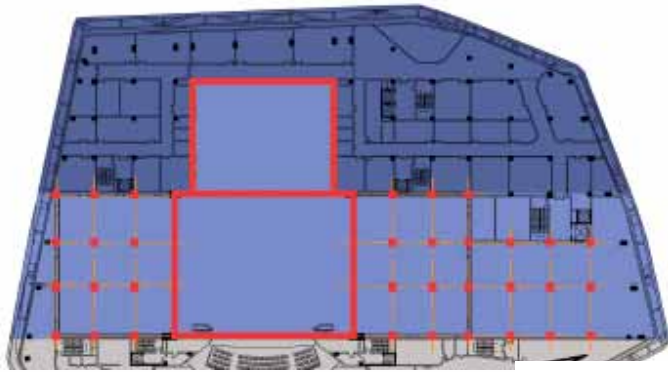
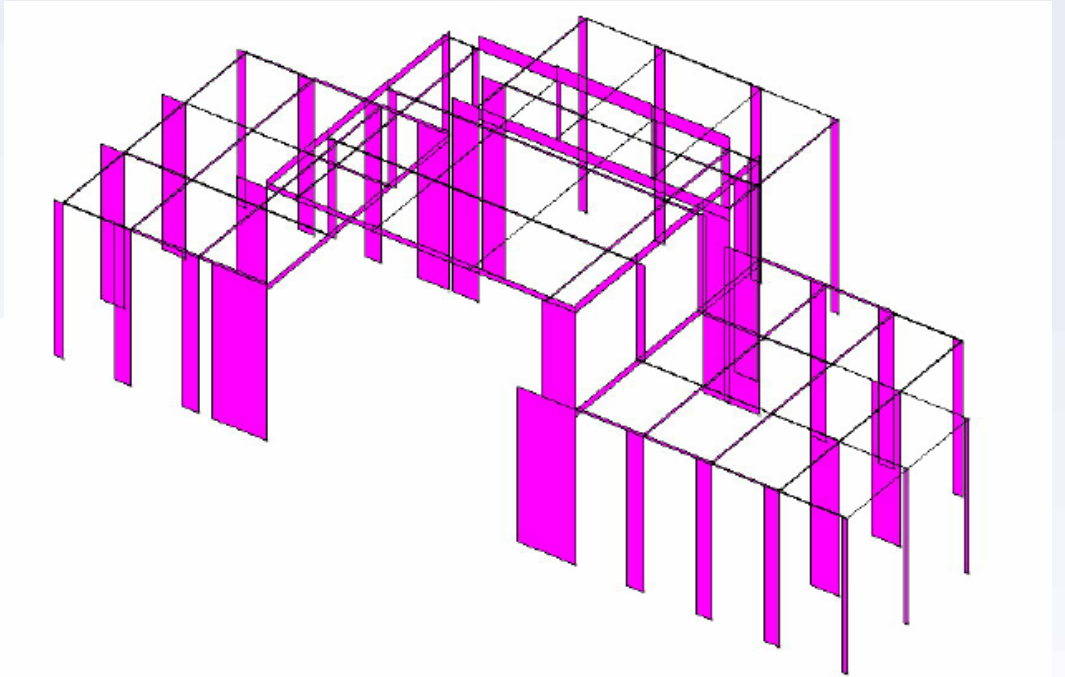

- Pressure

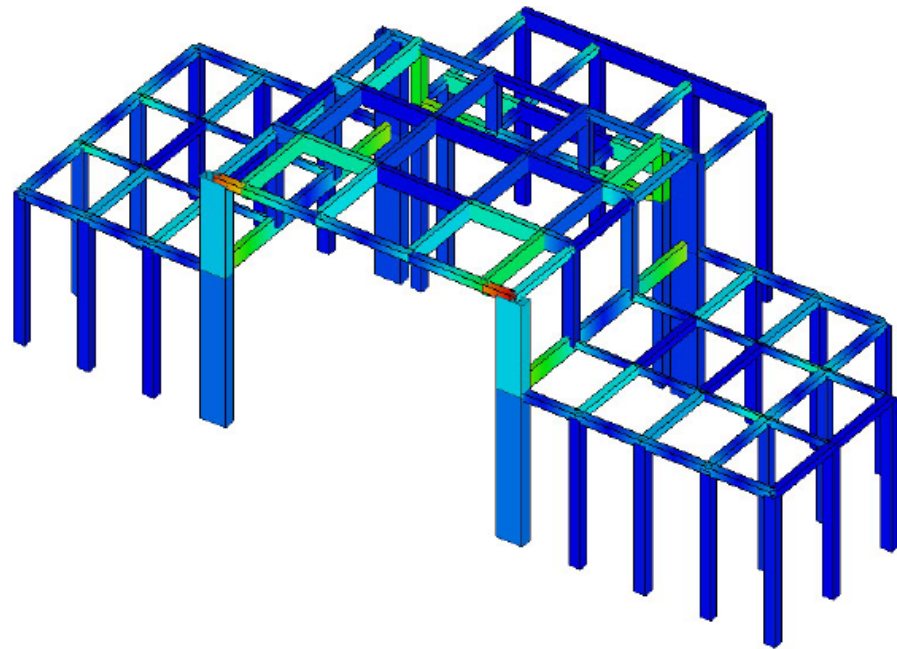

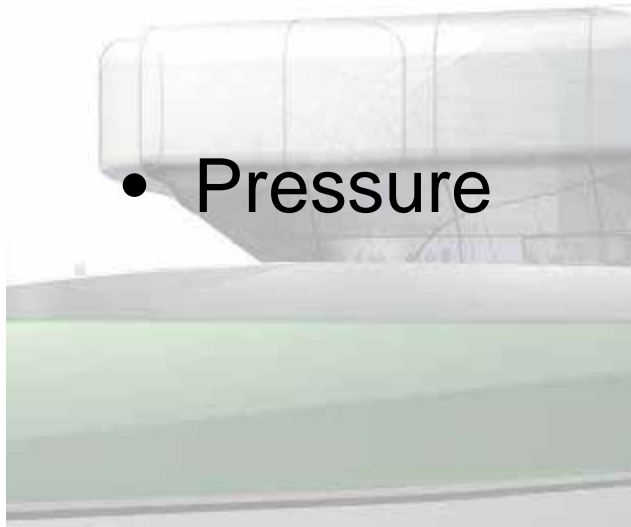
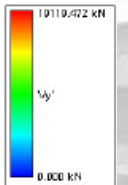
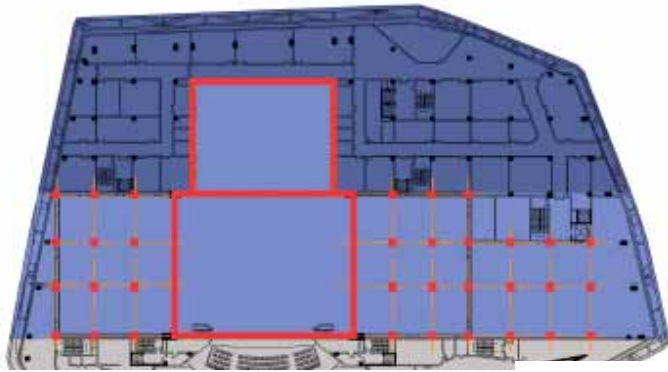
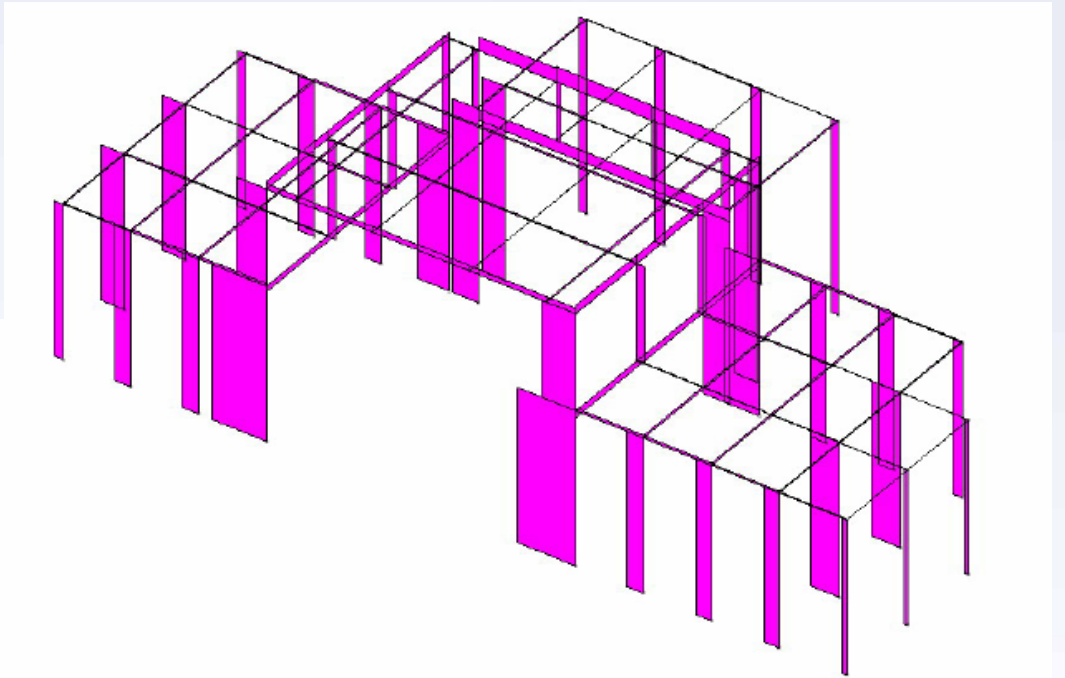

- Pressure

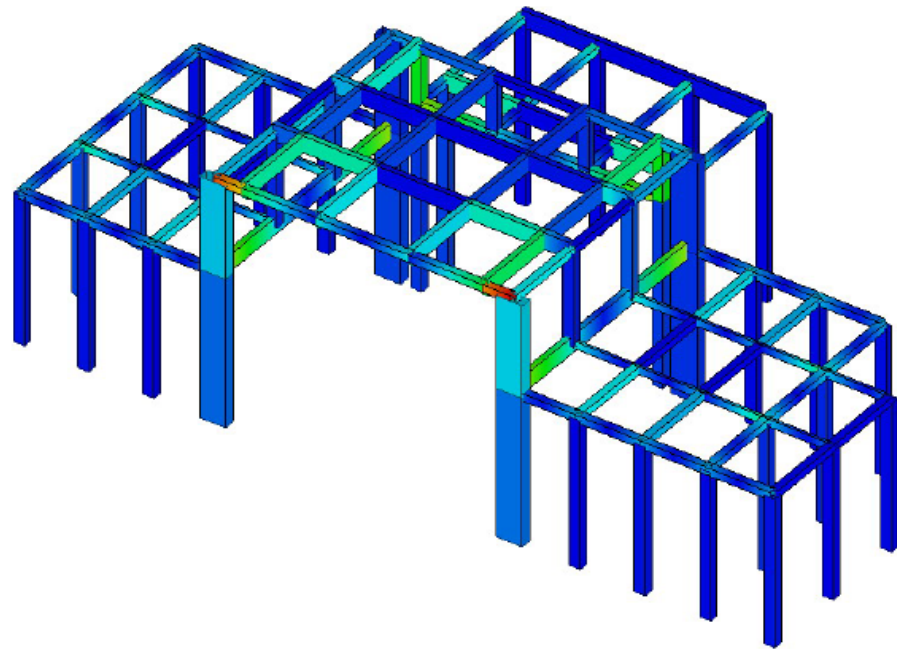

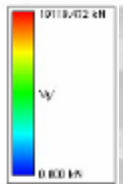
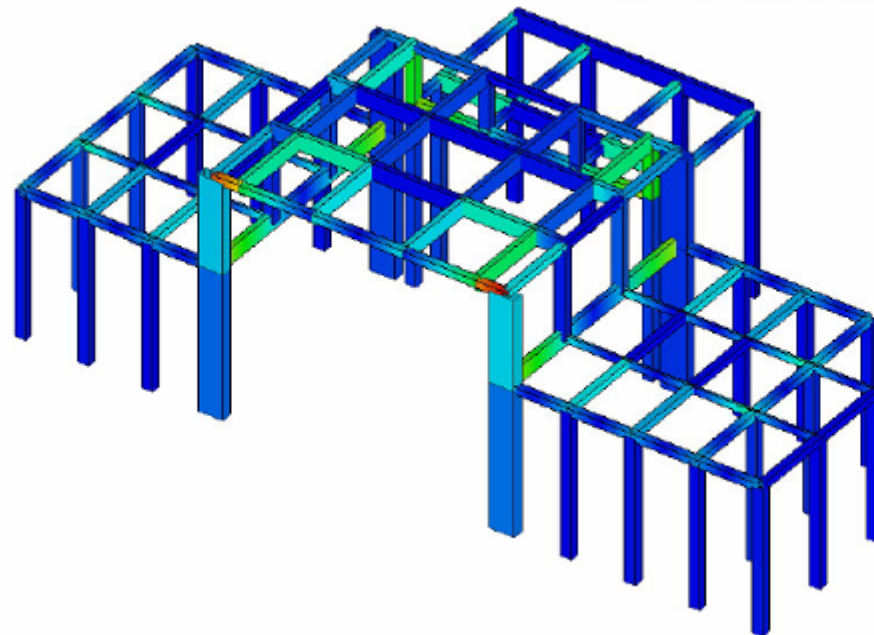
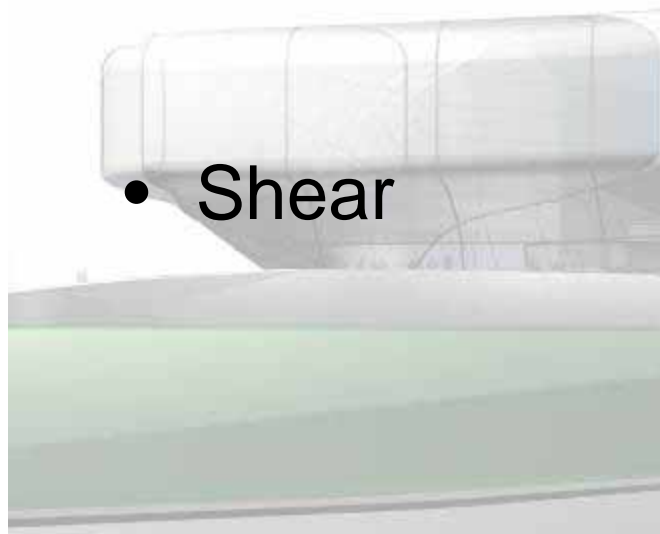
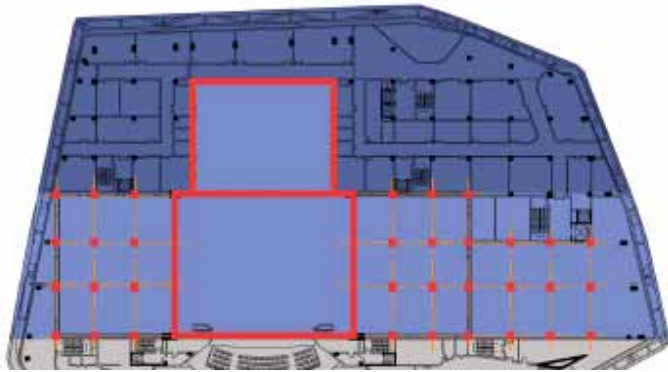
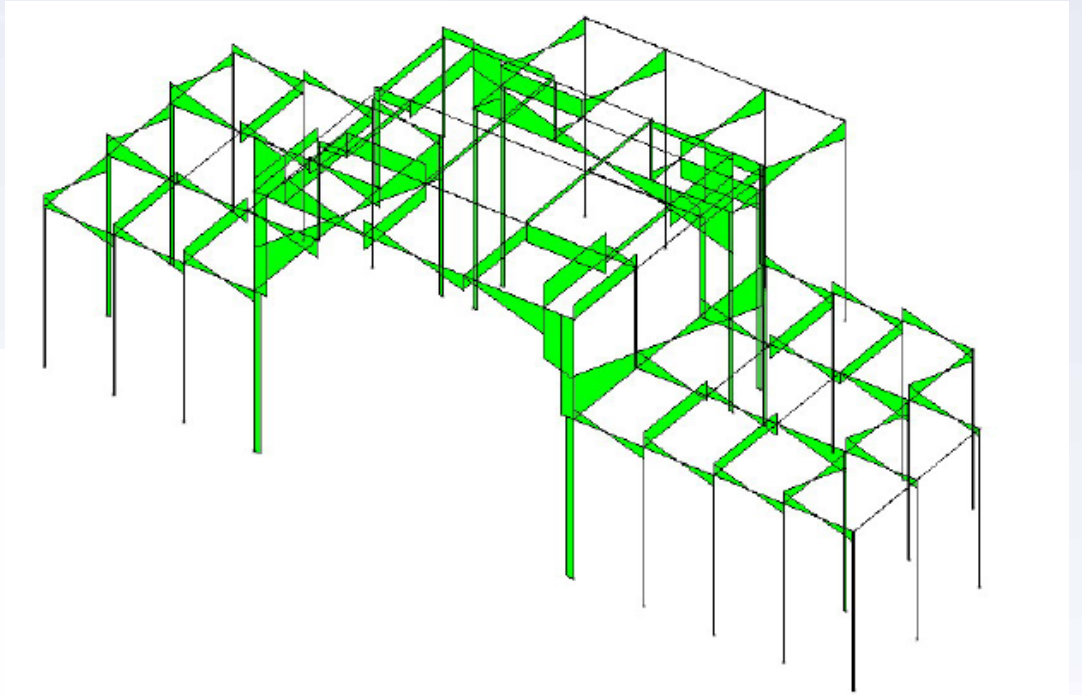

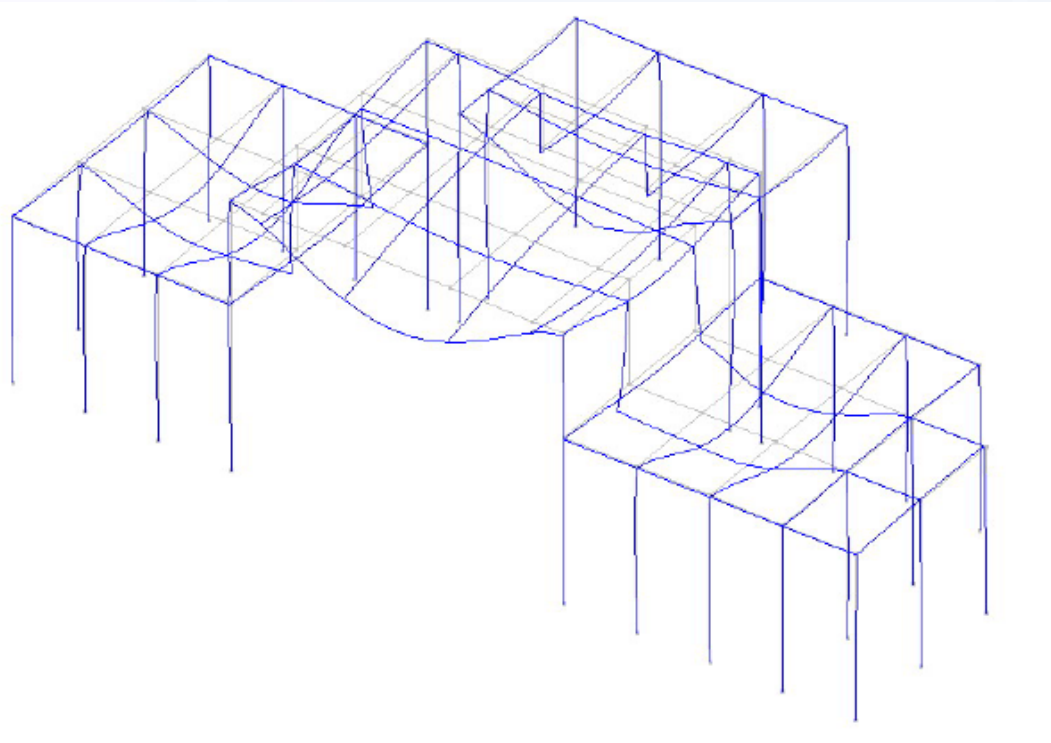
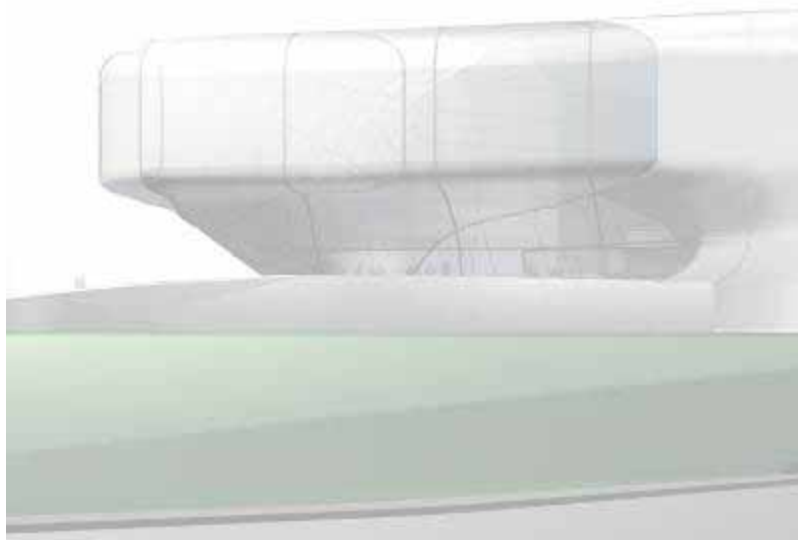
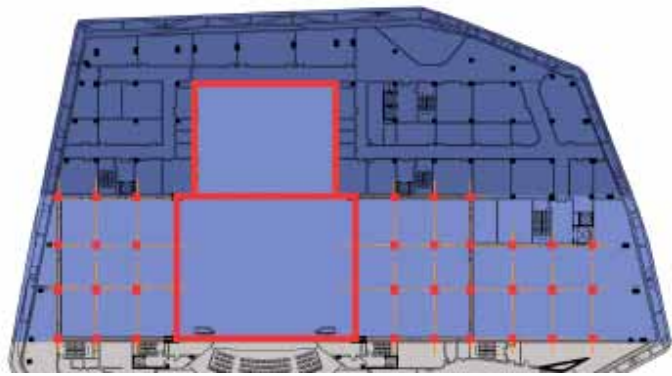

Auditorium

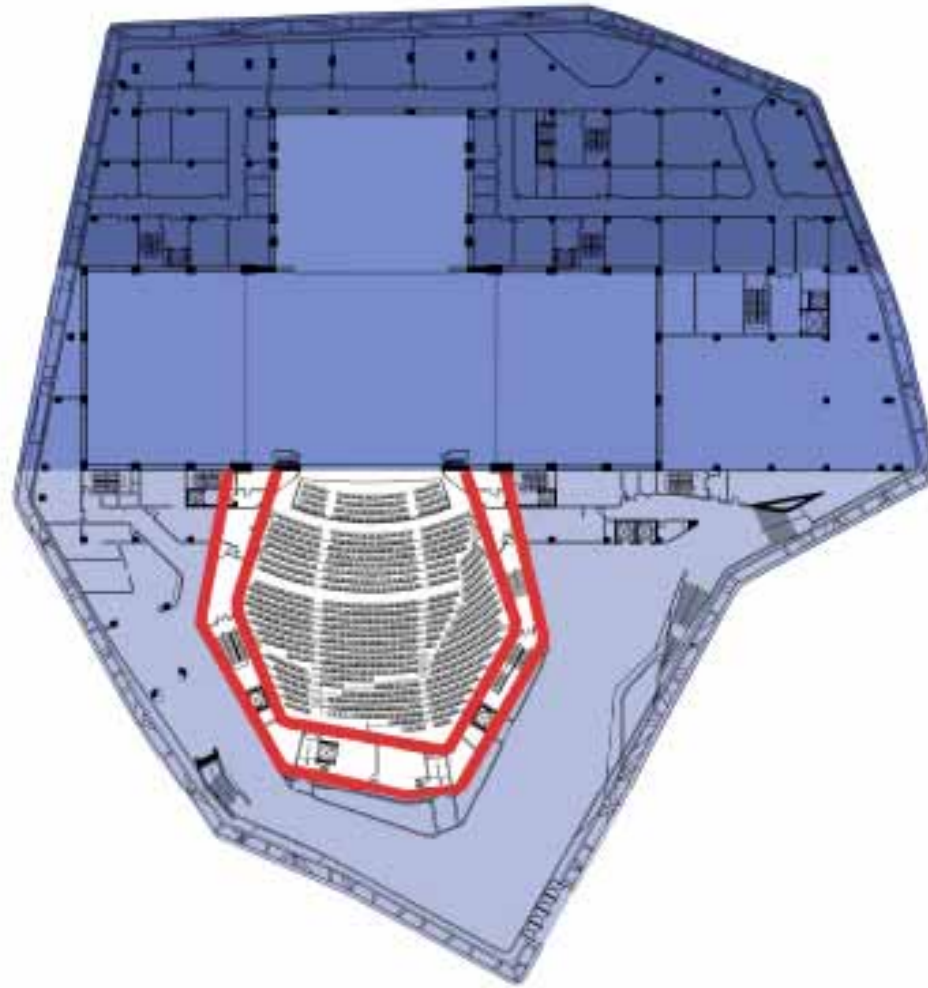

- The shear wall core (reinforced concrete): rigid horseshoe-shape dual wall to support balconies, foyer and the roof.
- The exterior and partial interior walls of the concrete core are intersecting with certain dip angle
Maximum dip angle: 30°

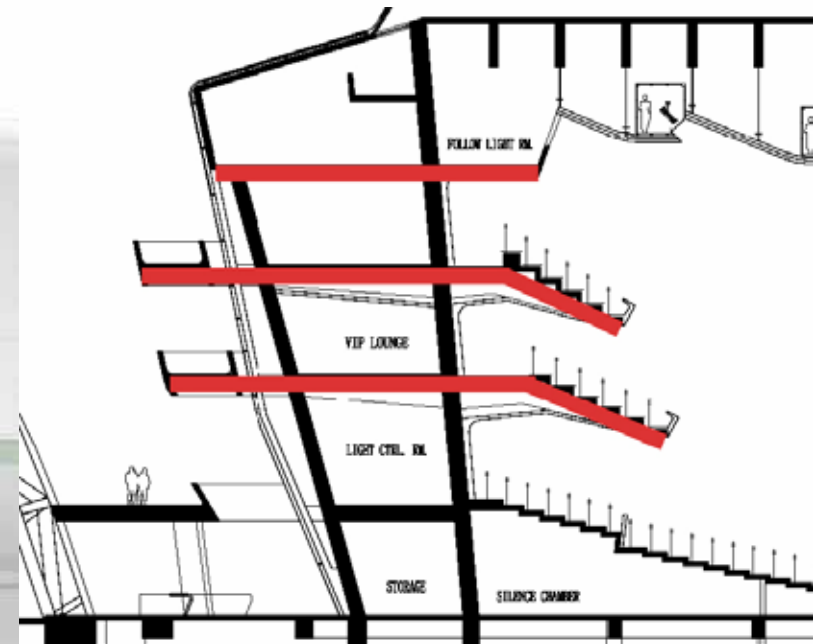
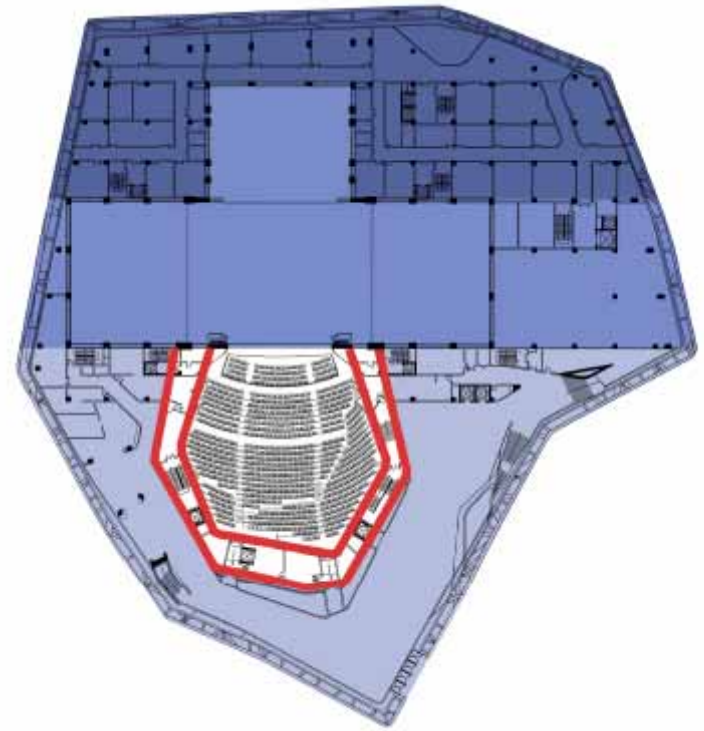



Moment

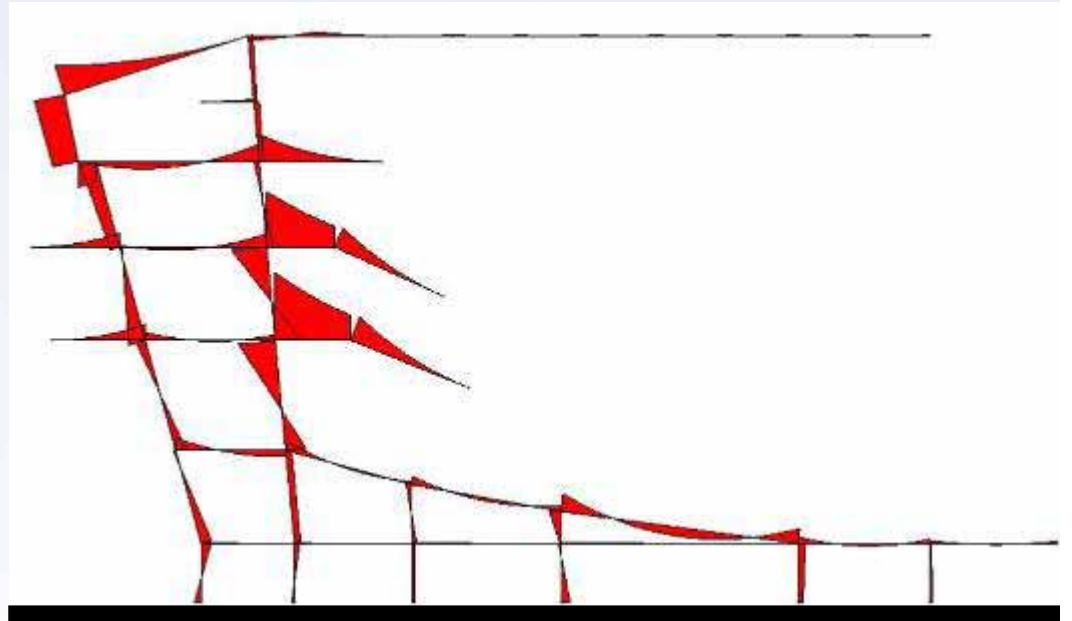

Fixed into the dual shear walls, rigid connected

Span reaches to 11 meter, steel frame structure

Shear

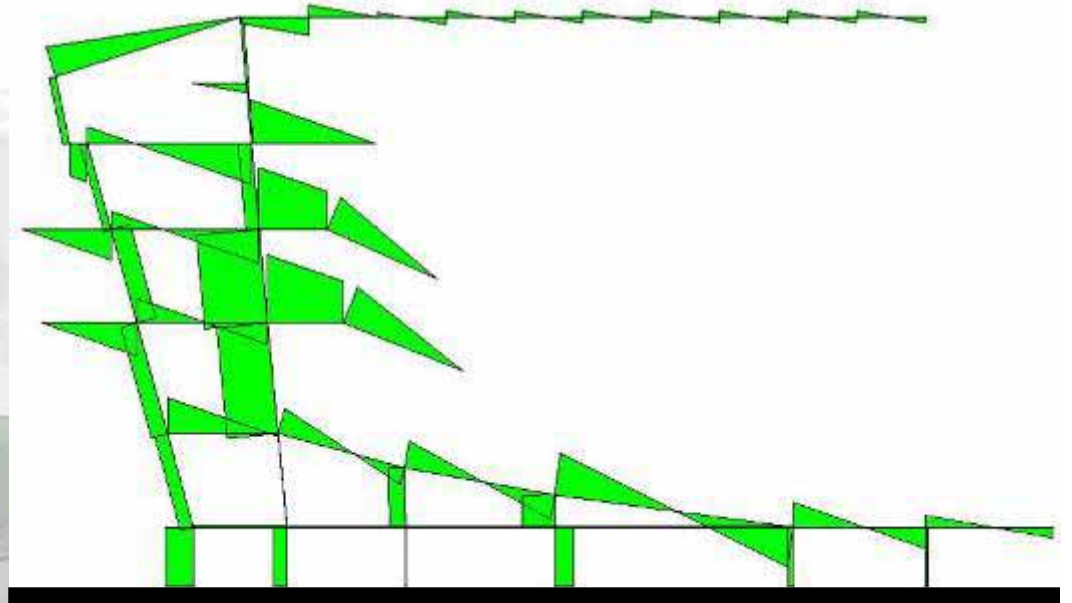



Pressure

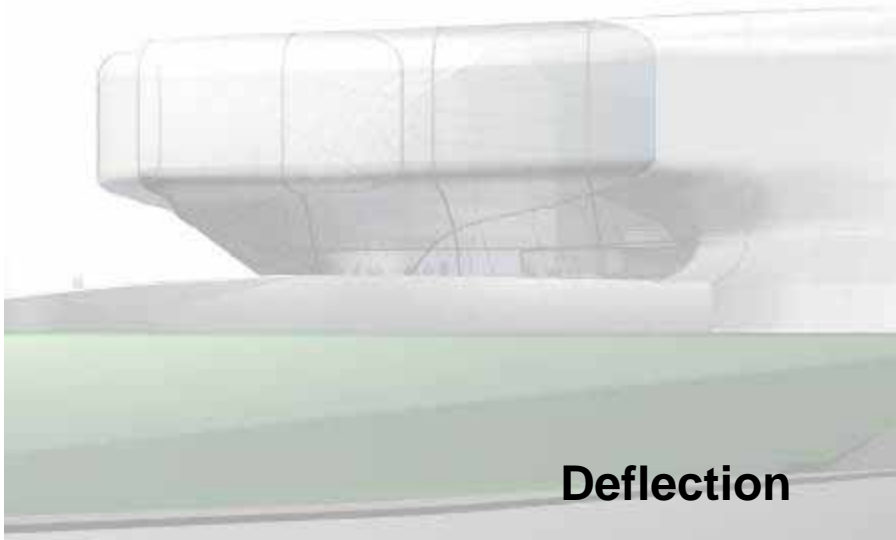

Deflection

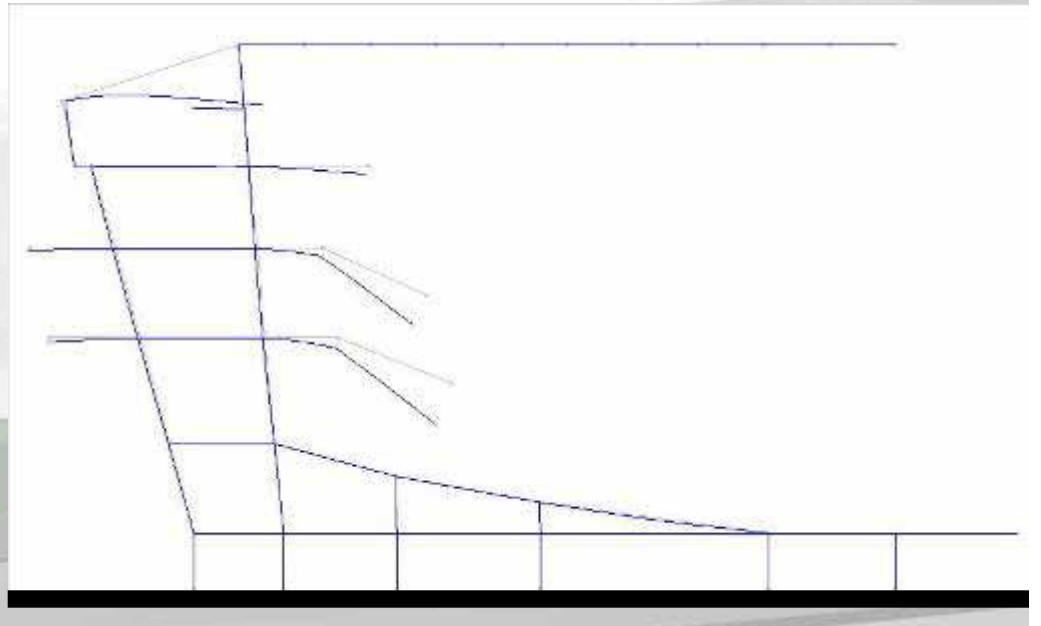

The structure floating on the ground

- Floating construction.
- Steel spring box.
- Adjust the frequency of the building's vertical vibration & to reduce the noise
- Reinforced concrete plate at the top of the spring to resist the distortion of the upper structure.

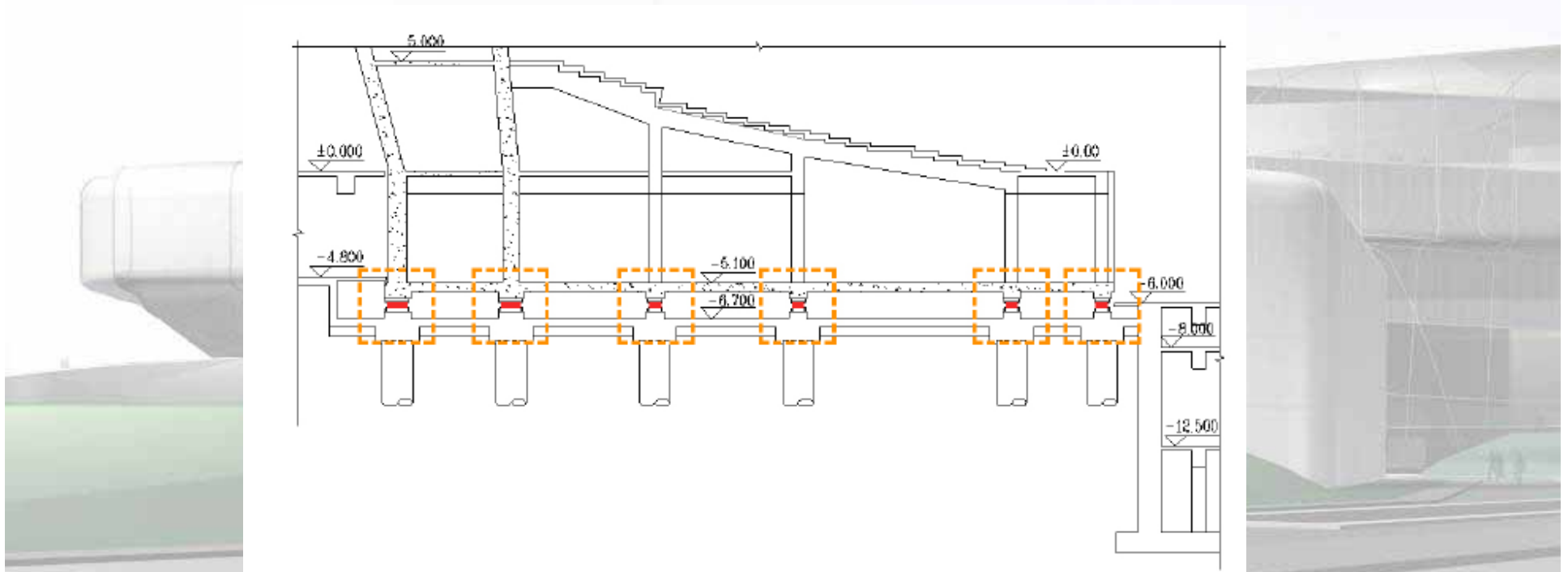

The design of the underground structure and foundation

- Flat open terrain of one level terrace.
- Artificial bored pile foundation
- The radius of the pile is 1200~2200cm, with the end's radius extends to 1600~3600cm.
- Single pile of single column. The pile shaft concrete strength is between C30-C35.

- The frame work of the underground floor plate is reinforced concrete plate.
- With this design, the floor plates provide a lateral bearing to the side walls to create an internal moment to resist the lateral force from the ground.

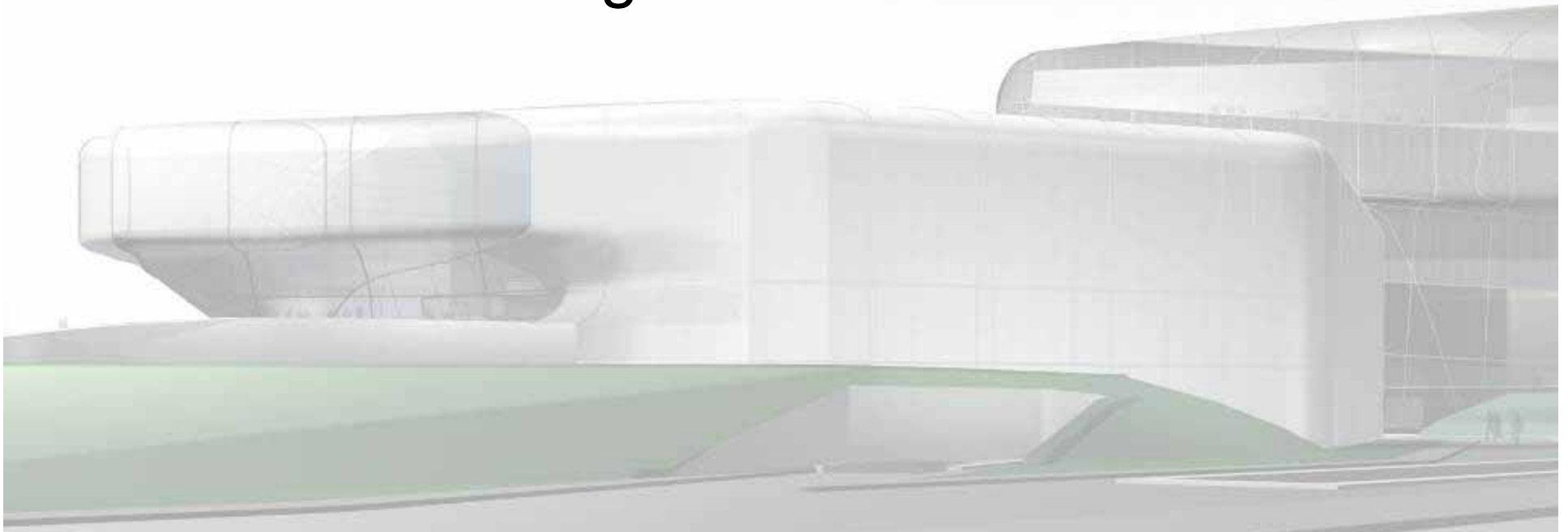

Long span structure without expansion joint

- There is no expansion joint in the underground structure.
- The underground is 200meters long.

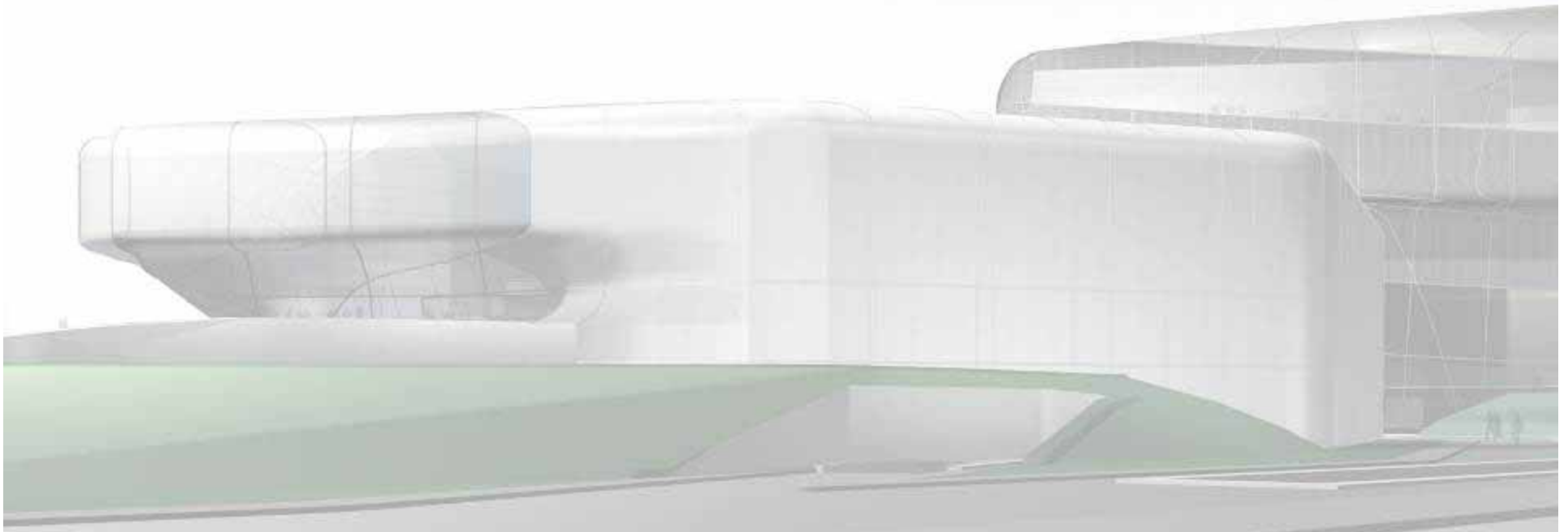

- Increase the reinforcement ratio at the weak area of the beam and put certain amount of extended rebar.
- Use the slightly expansive concrete admixture in the underground structure
- Consider late pouring band to reduce the negative influence of the shrinkage of concrete at the construction period.
- In the prerequisite of reaching the requirement of intensity and the pump ability of the concrete,
- Use the FOAMING SYSTEM OF RIGID POLYURETHANE
- Coil material is used in the external waterproof of the underground structure

Cast steel joint

- The steel structure combined by the spatial inclined planes.
- Welded hollow spherical joints
- Cast steel joint: The width of the web plate is 30-40mm. The flange plate is 1,4 times width of the web plate.

Cast steel joint

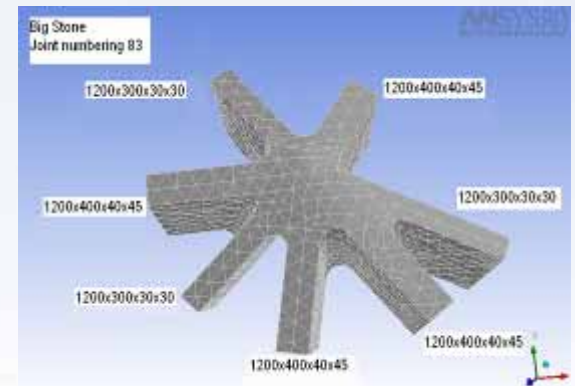

多功能厅铸钢节点

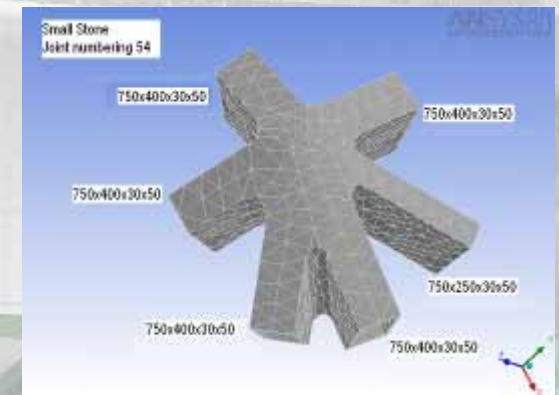

Conclusion

1. **Structure Unit Division:** Ensure that the each structural unit's type can match the different functional space rationally.
2. **Envelop System:** Form the long-span interior space and cover each parts of the building effectively.
3. **Floating System:** Reduce noise and isolate the vibration from the subway cross the site.
4. **Cantilever System:** Support gravity loads of multi-level grand stand
5. **Dual Shear Wall System:** Support partial envelop system, stages and equipments, and improve the auditorium's rigidity as an entire structural unit.

- *Creatively support splendid and amazing interior space to connect opera hall, multi-purpose hall and some other functional space as an integrated architecture.*
- *Successfully achieve vibration isolation and noise reduction to ensure the perfect acoustic quality.*
- *Totally support architect's design concept and develop an extraordinary and spectacular architectural form.*

References

- www.zaha-hadid.com
- www.abbs.com.cn
- www.far2000.com
- www.ycwb.com
- archrecord.construction.com
- www.arcspace.com
- “Time Architecture” ISSN 1005-684X
- “The Architect Journal” ISSN1001-6740
- “South Architecture” ISSN 1000-0232
- “Architectural Journal” ISSN 0529-1399
- “Structures” Schodek, Daniel L
- “Building Structures-from concept to deisgn” Millais, Malcolm
- “Structure and Architecture” Angus J. MacDonald