



Nasher Sculpture Center

Case Study Project

Sheldon Henning Courtney Kelly Ellen Kiel Abby Leonard Brant Moore



The Nasher Sculpture Center represents Ray Nasher's vision to create an outdoor "roof-less" museum that will serve as a peaceful retreat for reflection of art and nature and public home for his collection of 20th-century sculpture.

The collection, valued at \$500 million, was stalked by a dozen major museums, including the National Gallery of Art, Guggenheim, and Tate

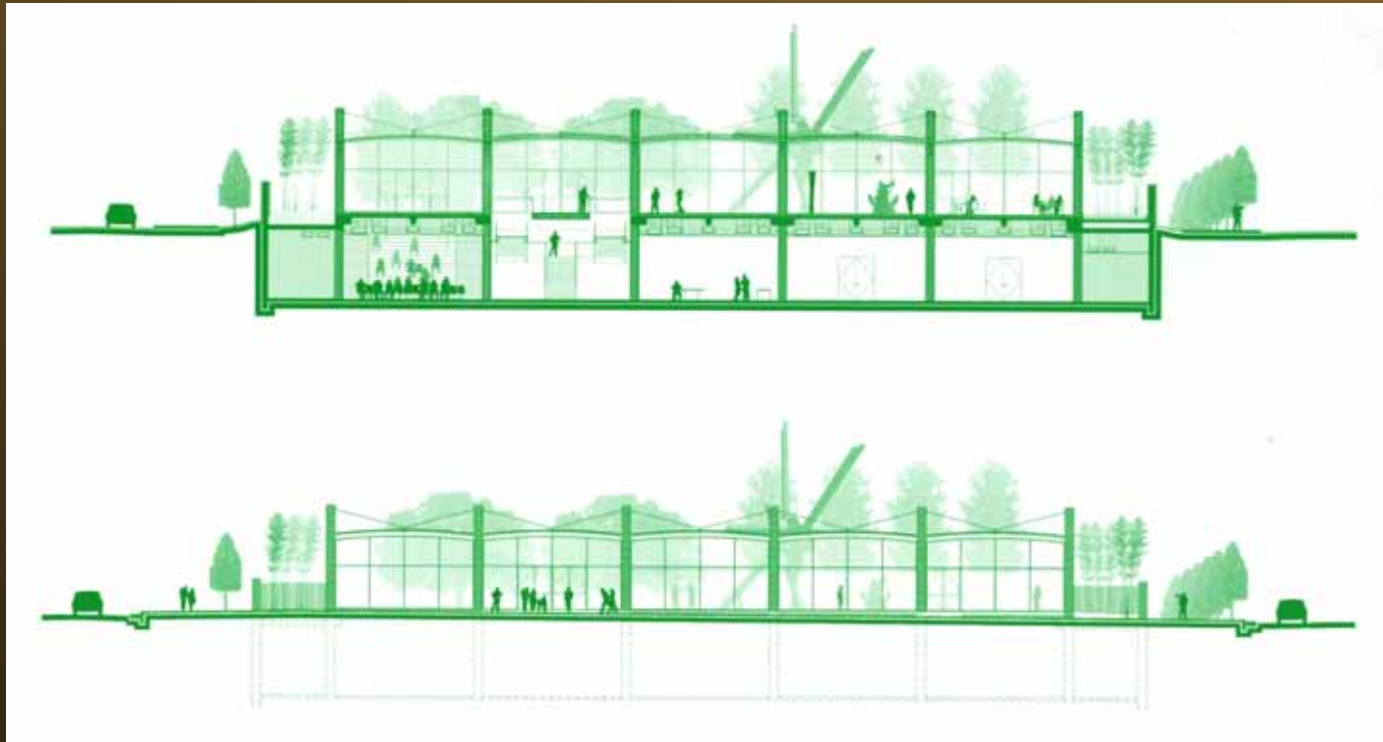

Raymond Nasher decided to keep it in Dallas where he'd made his fortune as a shopping center developer and foot the project's \$70 million bill himself.



The goal was to produce **a structure of lasting significance** that will sustain the legacy of the collection-- a kind of noble ruin **reminiscent of** the solidly-grounded archaeological sites of **ancient civilization** and their continuity through time.



Large gallery windows seem more similar to a fancy department store than a museum, possibly representing Nasher's history in shopping center development



- 1.5-acre garden
- 55,000-square-foot pavilion
- Five vaulted bays: three housing art, a restaurant and museum shop
- Lower level library and additional galleries
- Auditorium opening onto the garden

Main Structural Components

- 248 extra-white glass panels (228 shaded, 20 unshaded), each 4' x 16', 1,200 lbs.
- 60 opaque steel panels, each 4' x 16', 1,200 lbs.
- Roof height: 16' at the wall, 17' at the center point
- Glass systems by Sunglass (Padua, Italy)
- 912 sunshade pieces, each 4' x 4', 150 lbs.
- Sunshade apertures face due north to block direct sunlight
- Aluminum sunscreens by La Societa Sider s.r.l. (Bologna, Italy)
- Roof system: 161 steel roof beams, supported by 322 steel tension rods
- Structural steel by Gipponi s.r.l. (Bergamo, Italy)
- Main staircase: three stairs, each 15,000 lbs. and landing, 20,000 lbs., fabricated from cold rolled steel



“Sprezzatura” (Italian) the art that conceals art

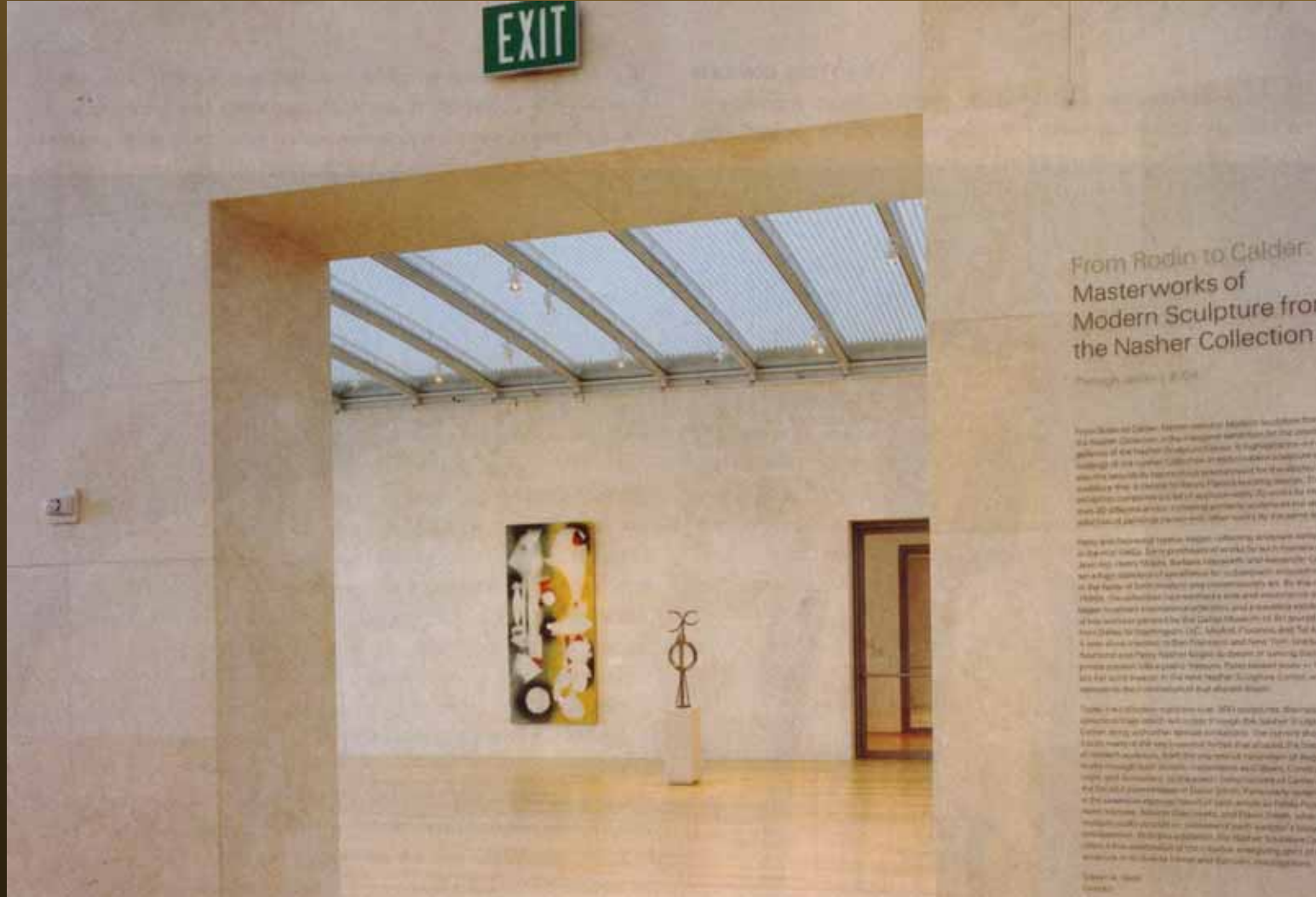

Ducts, cables, and sophisticated electronic gear lie crammed within its thin travertine walls, but nothing shows. Granite benches in the garden conceal pumps and electrical boxes; even the loading dock is tucked out of sight.

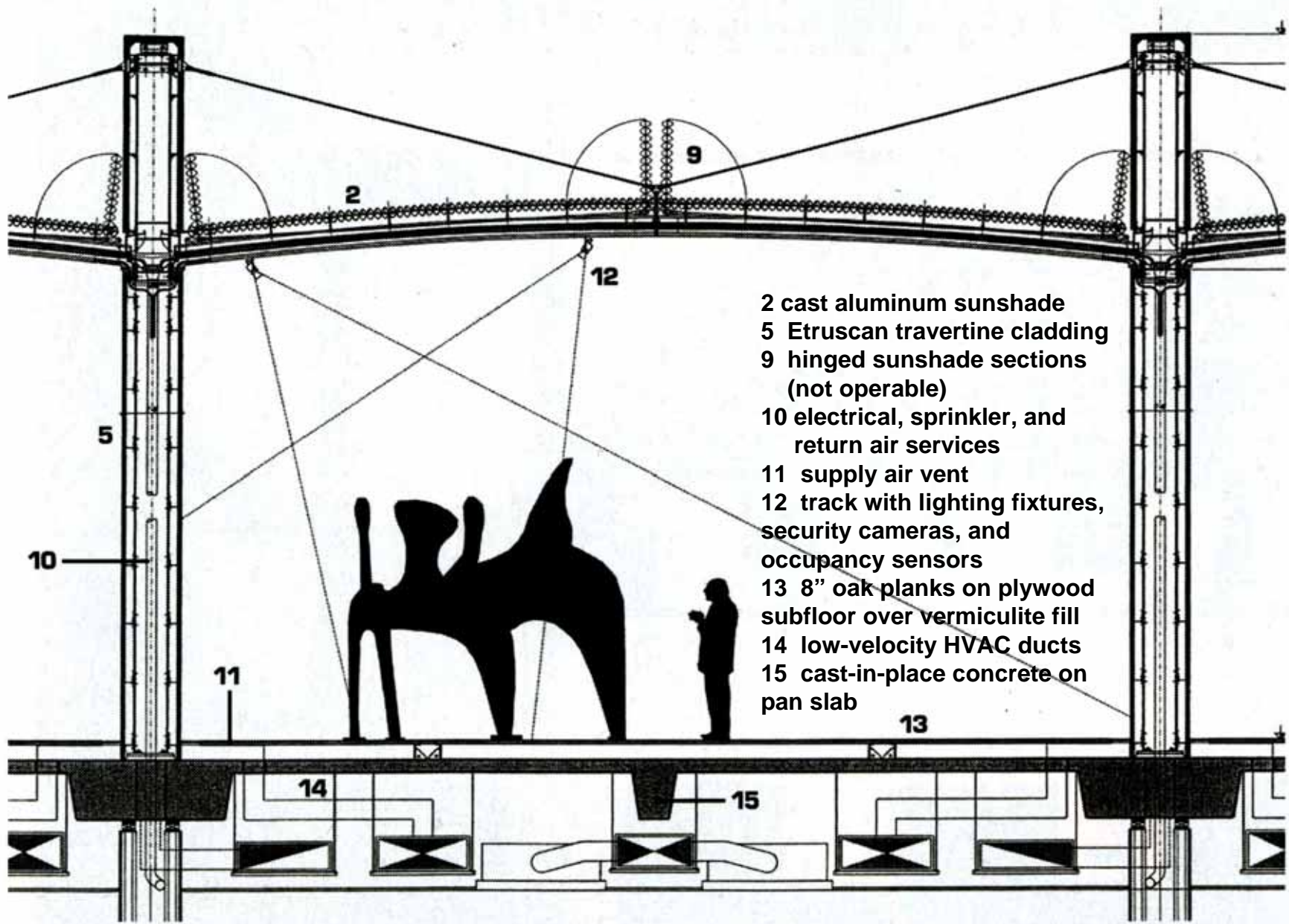

partial section 3.5'

- 1 stainless-steel hardware
- 2 cast-aluminum sunshade
- 3 two layers laminated 3/8" glazing
- 4 laser-cut bent solid-steel plate

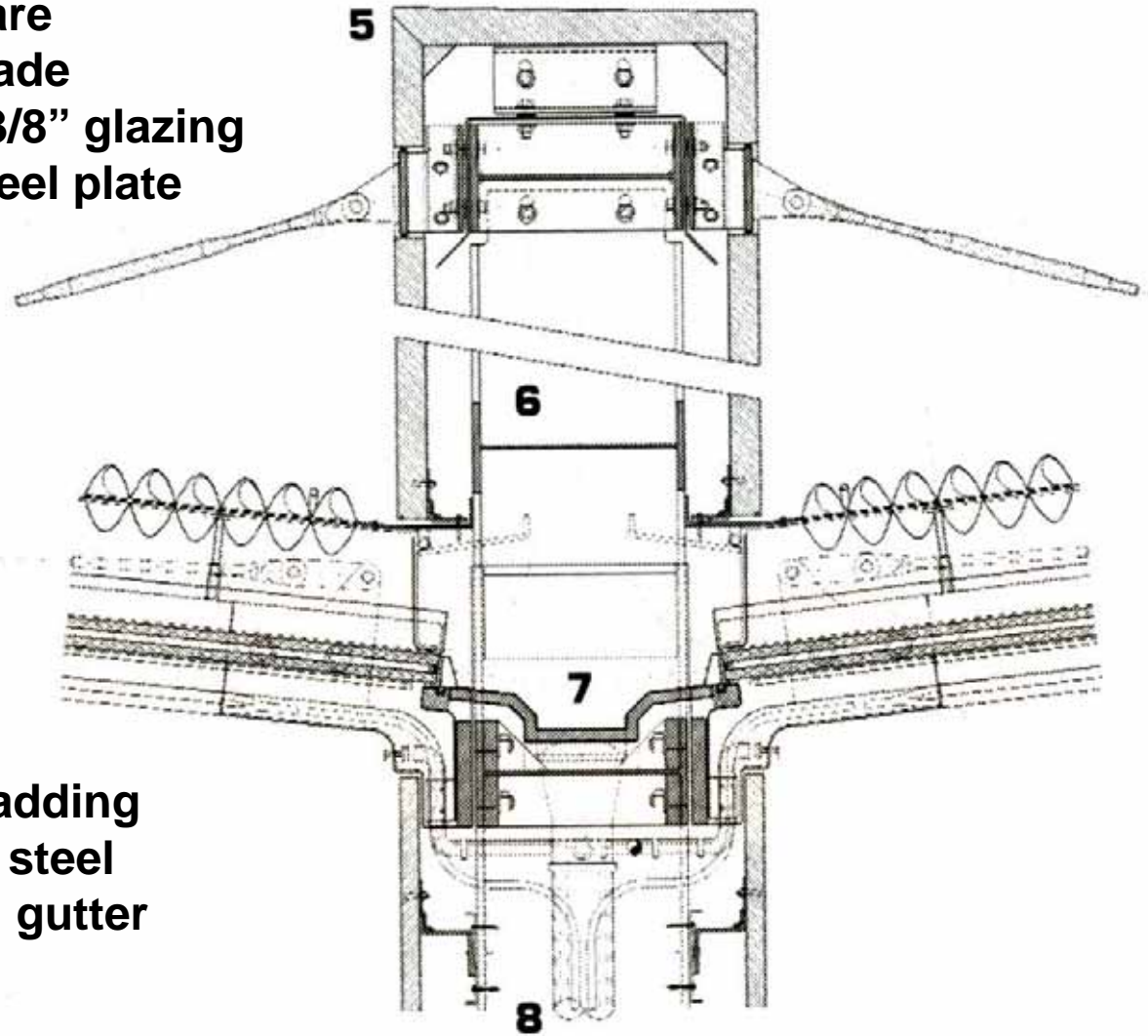
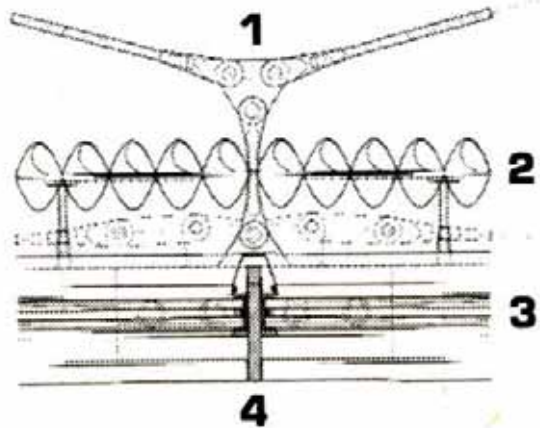

- 5 Etruscan travertine cladding
- 6 wide-flange structural steel
- 7 welded stainless-steel gutter
- 8 drain

roof-wall detail 12"

1 stainless-steel hardware

4 laser-cut bent solid-steel plate

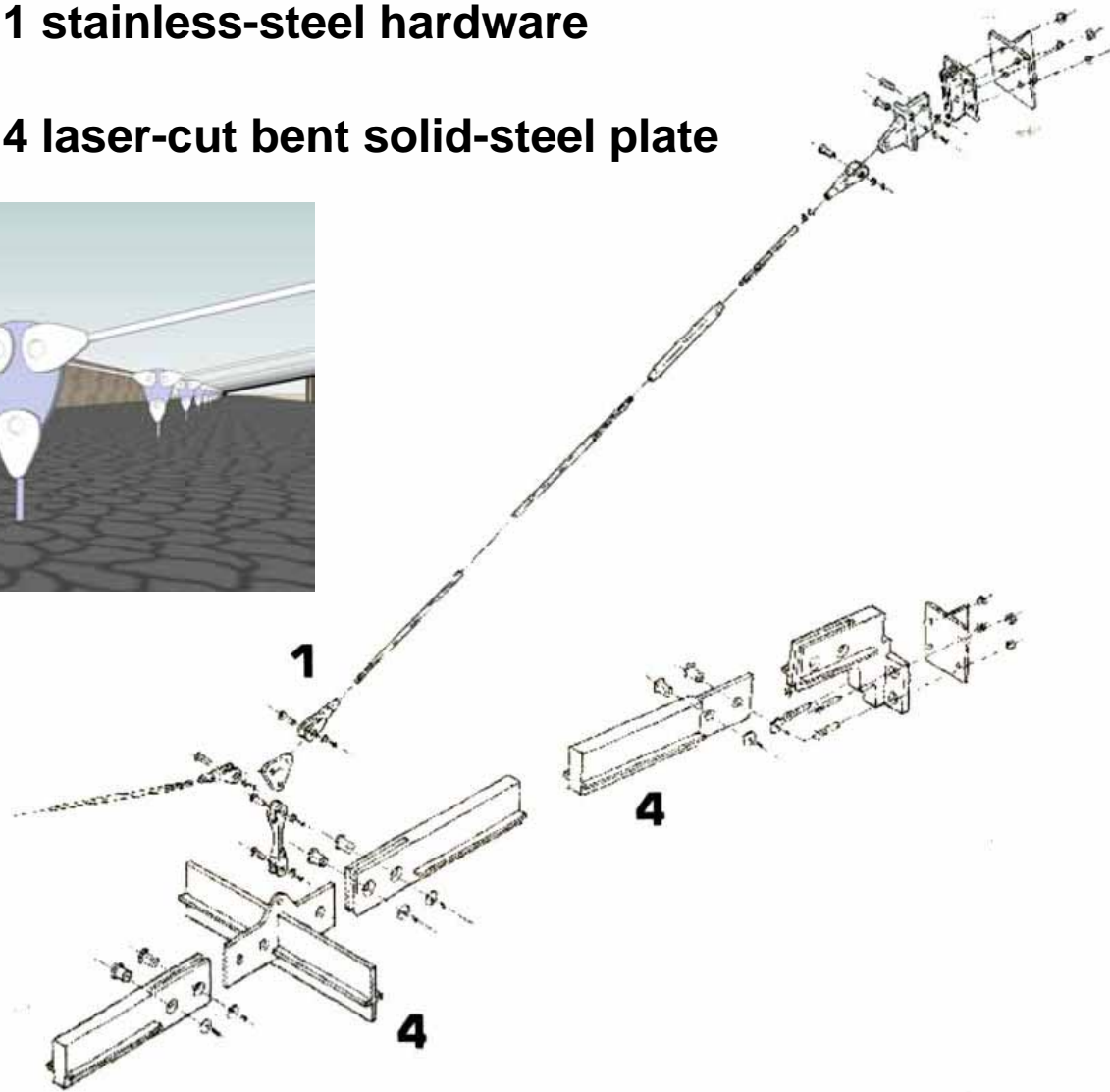
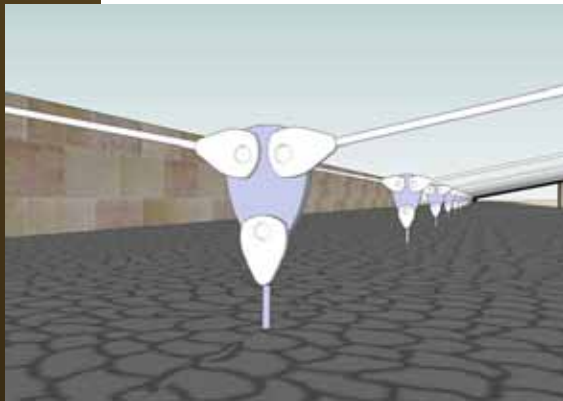

structural-steel assembly diagram _____ 22"

“A Museum Without A Roof”



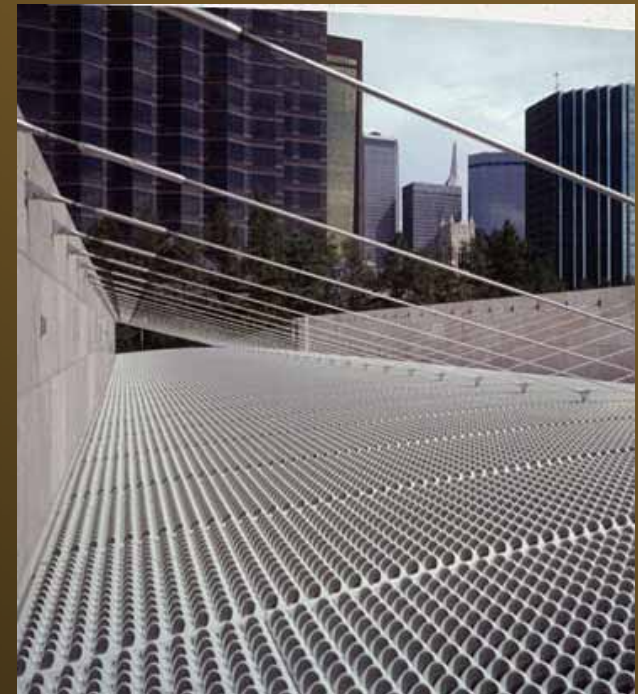
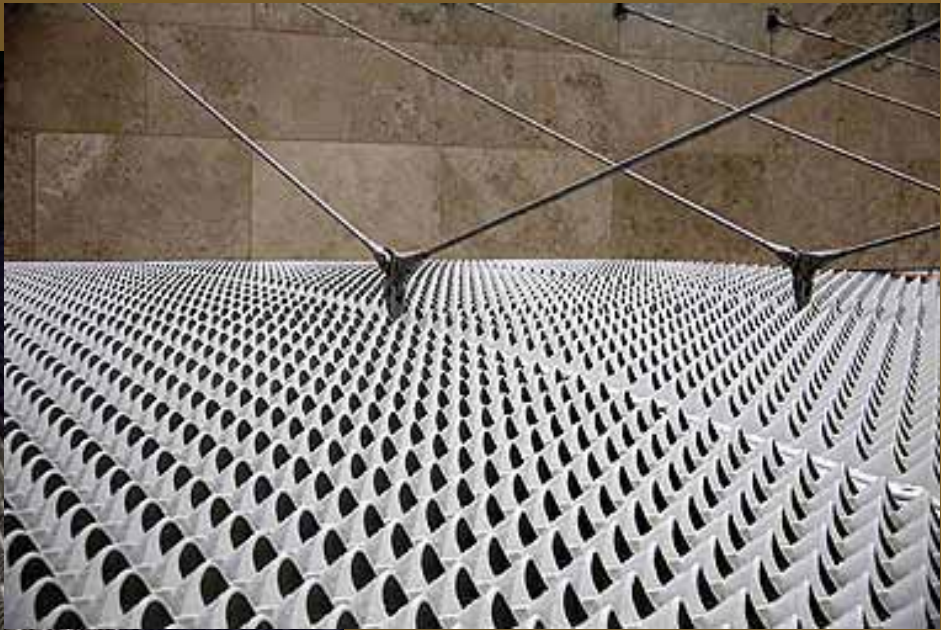

Over 500,000 aluminum 'eggshells'
each weighing 1.4oz (40g)

Shading Structure

The curved form is based on a sine curve passing through the east and west corners

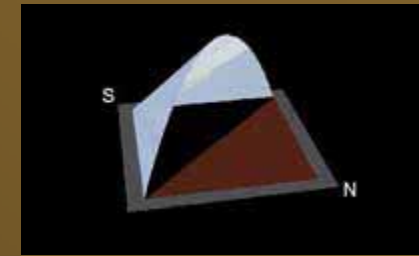
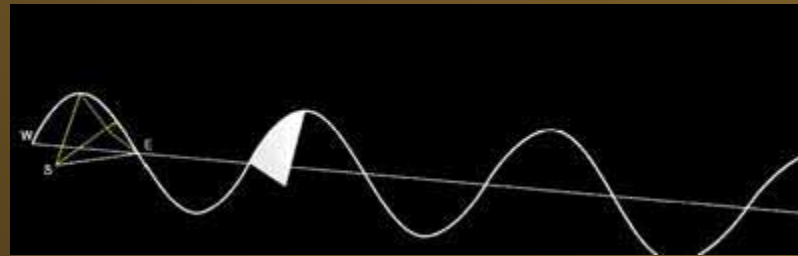
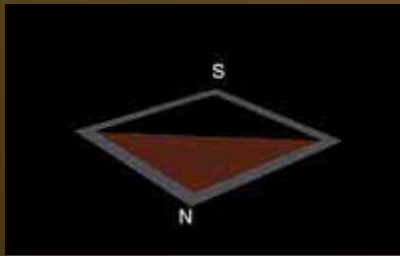

A surface is formed by the sine curve and the sides of the square

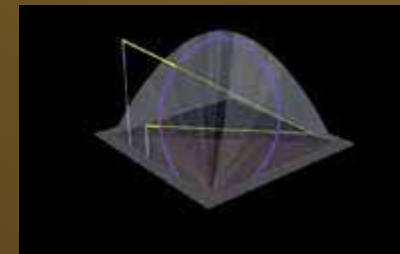
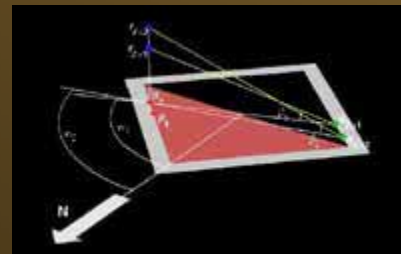

A shading curve is calculated on the surface from which the area is removed



This shape is mirrored on the bottom to create the final 'eggshell'

Lateral Resisting Elements



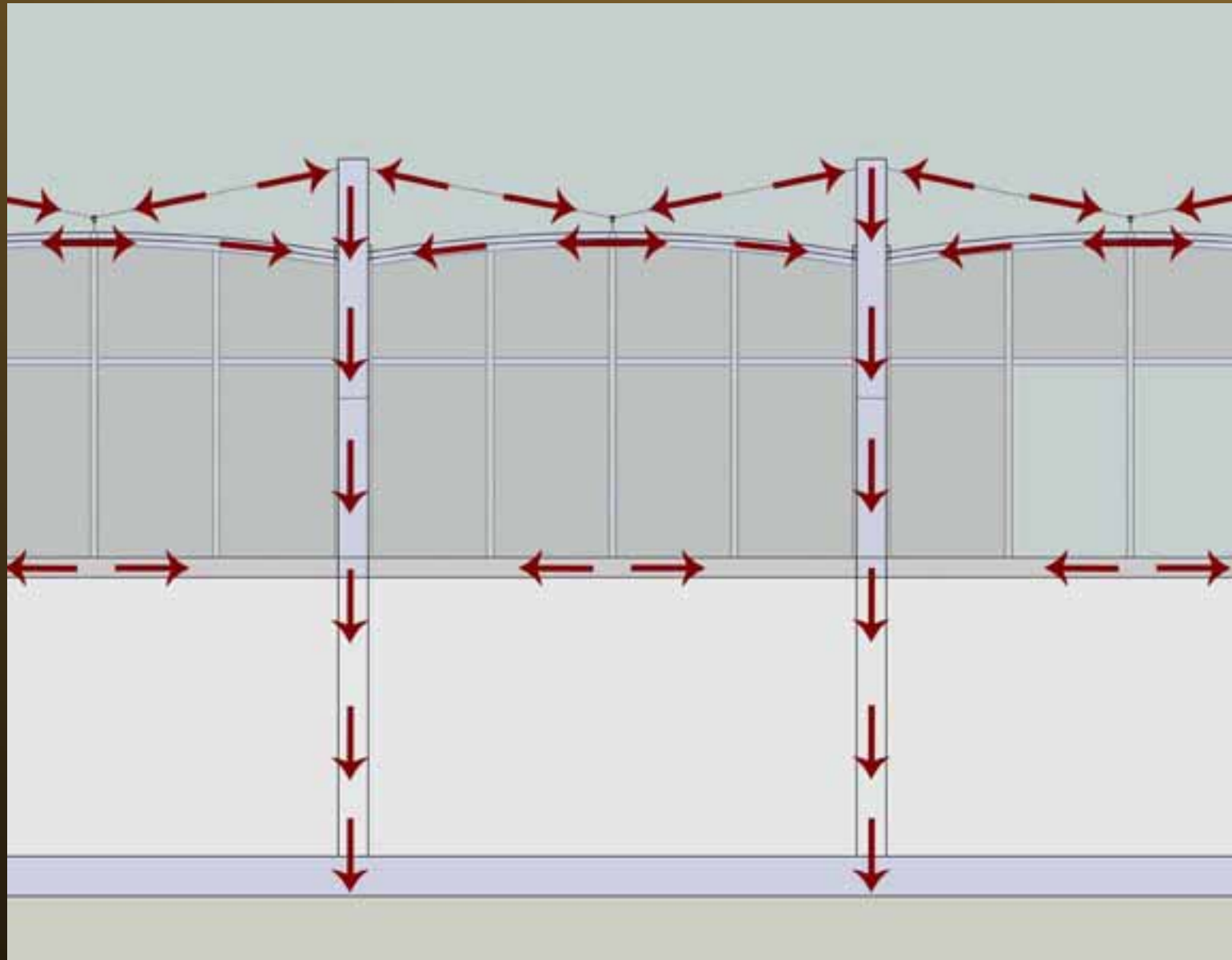

Loads Diagrams

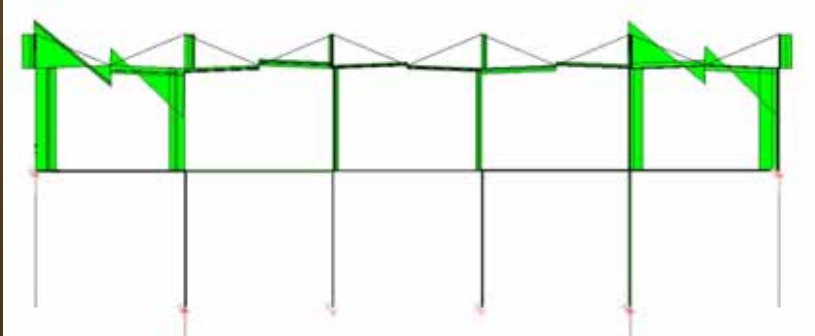

- Shear

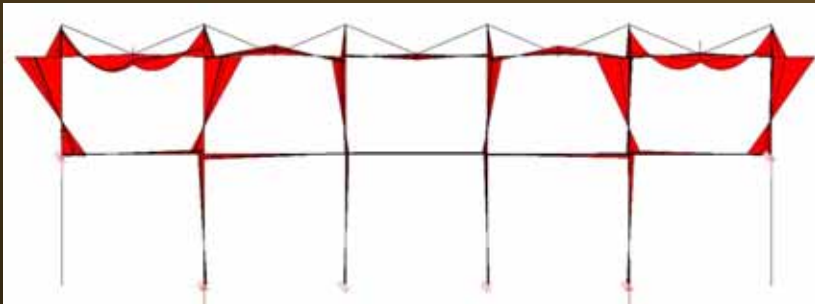

- Moment

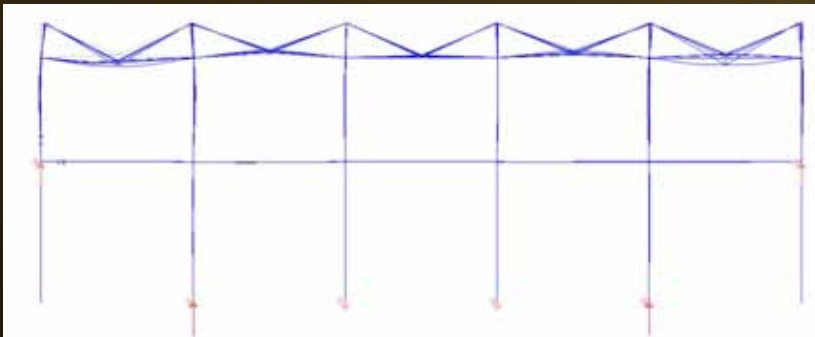

- Deflection

Lateral Load

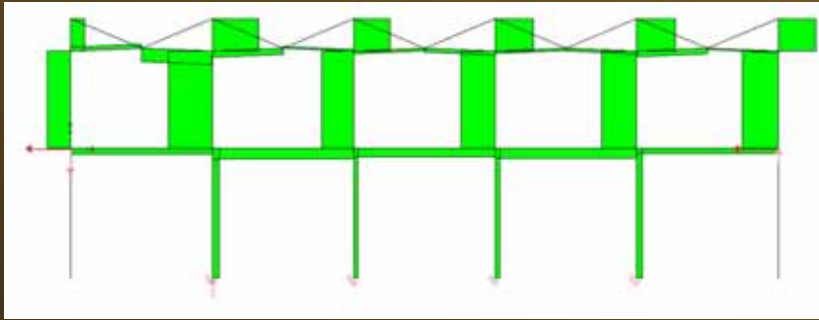

- Shear

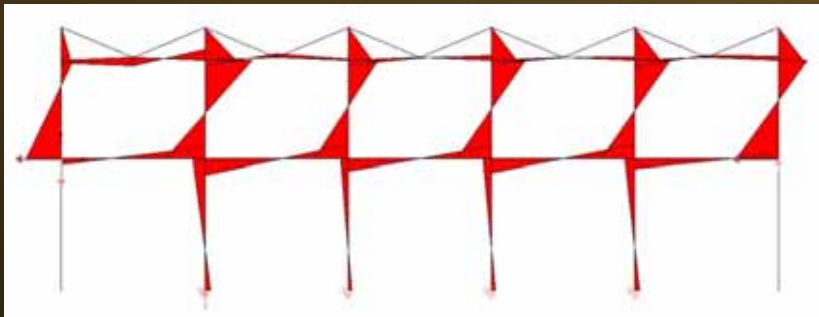

- Moment

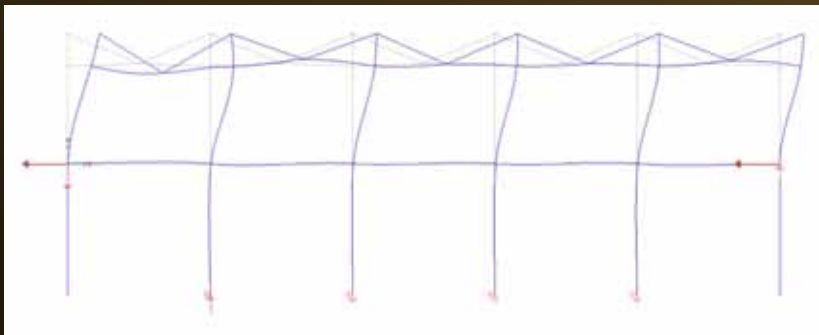

- Deflection

Foundation/Soil

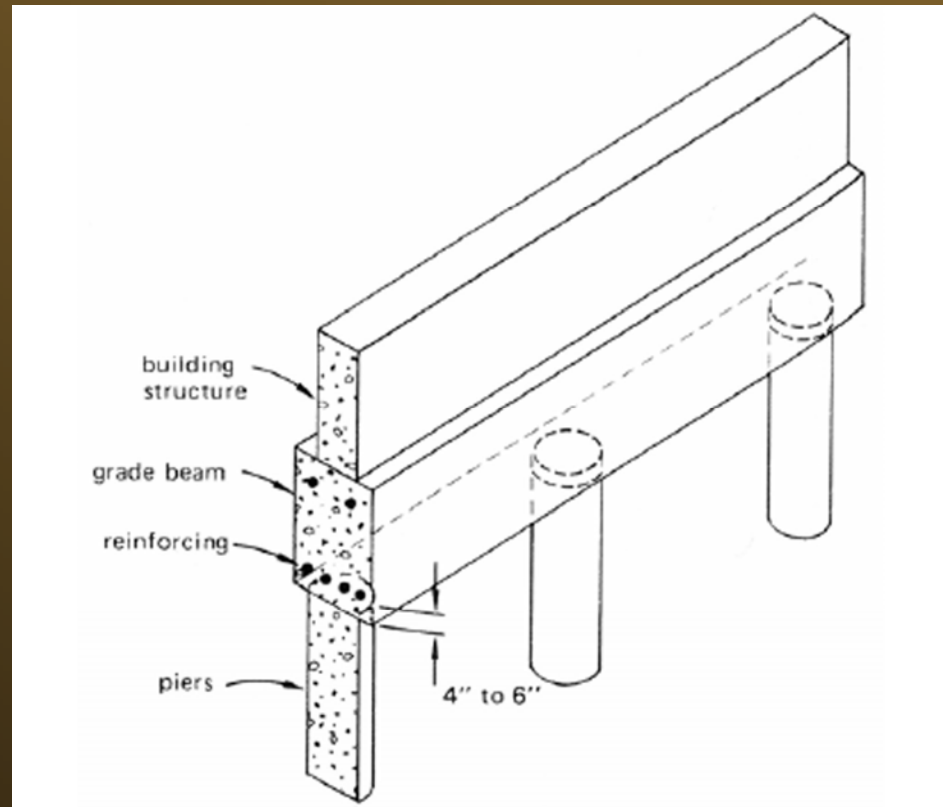

- Grade beam on piles
- Clay soil

References

- Buchanan, Peter. “Tuned Instrument.” The Architectural Review vol. CCXV no. 1288 (2004): 46-52
- Bussel, Abby. “These Boots Are Made For Walking.” Architecture vol 92 no. 12 (2003): 86-93
- Dillon, David. “For Dallas, An Urban Solution.” Landscape Architecture vol. 94 no. 3 (2004): 84-91
- Dillon, David. “Nasher Sculpture Center, Texas.” Architectural Record 01.2004 (2004): 100-105
- Jodidio, Philip. Piano, Renzo Piano Building Workshop. London: Taschen, 2005.
- <http://www.nashersculpturecenter.org>
- Ann Nichols’ Class Lecture Notes: Lecture 27