

P. David Romei **Arts Center**

2275 Dartmouth Avenue
College Station, Texas



Owner : Arts Council of Brazos Valley

Architect : Jim Singleton Architects

Structure : Robertson Consulting Engineers



Political / Funding Background

The P.David Romei Arts Center is a public building funded through donations and w+

ith a portion of the Brazos County hotel tax. The center is home to over 40 local artist groups, including the Brazos Valley Veterans Memorial, the Brazos Valley Art League, the quilter's guild and many more.



Programming & Function

The 5500 square foot building houses administrative offices, a retail space, classroom space, and a gallery for display. The city was constructed on public land in the Wolf Pen Creek Parks and Recreation District. It overlooks the Wolf Pen Creek amphitheater. The site will also be home for a permanent sculpture by Russian artist Dmitri Koustov.

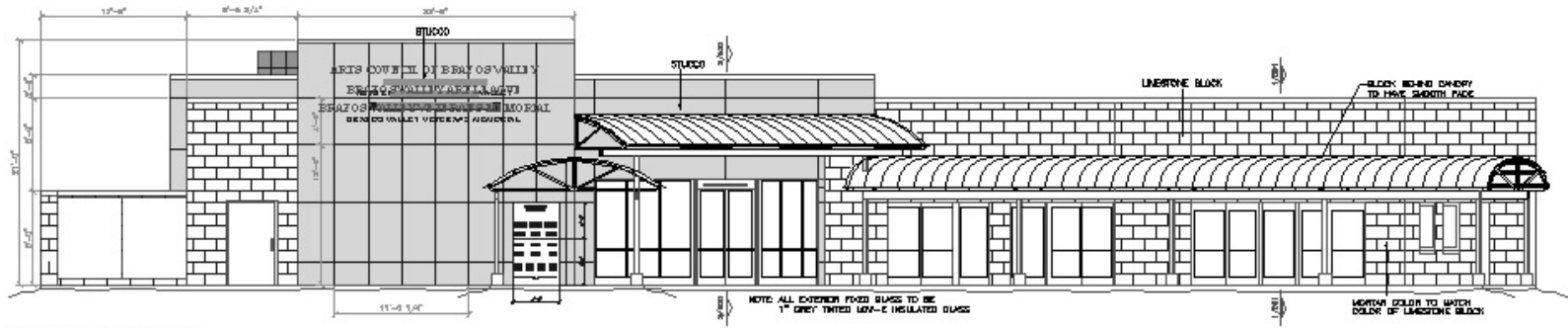

1 NORTHEAST ELEVATION

REF. R/AE

1/4"=1'-0"

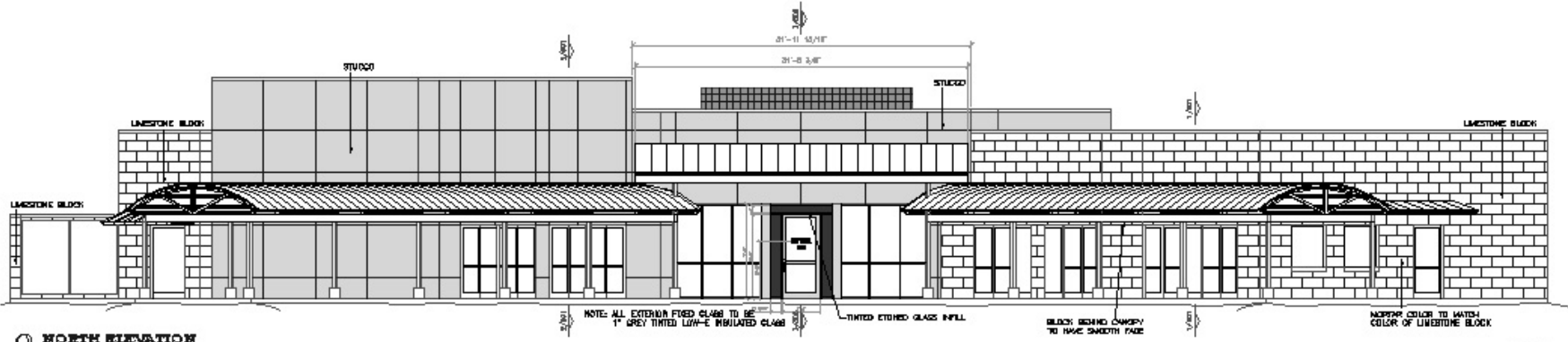

2 NORTH ELEVATION

REF. R/AE

1/4"=1'-0"

LIMESTONE BLOCK: 4" THICK X 12" HIGH X 18" LONG

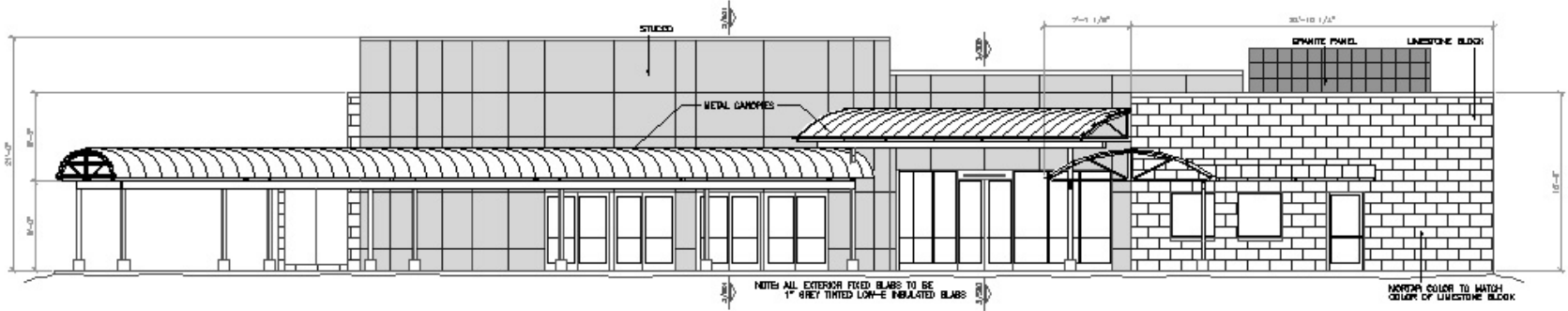

3 NORTHWEST ELEVATION

REF. R/AE

1/4"=1'-0"

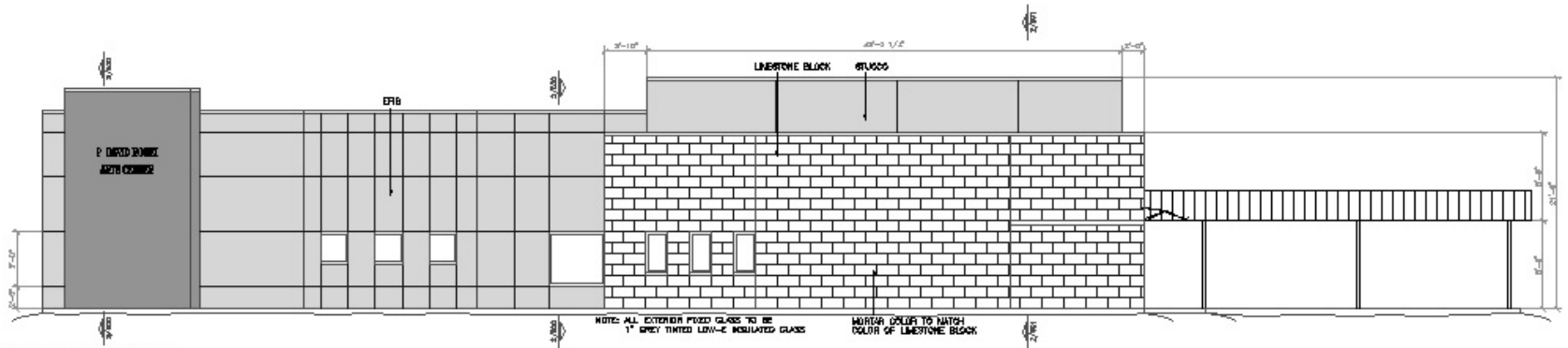

1 SOUTHEAST ELEVATION
REF. NONE

1/4"=1'-0"

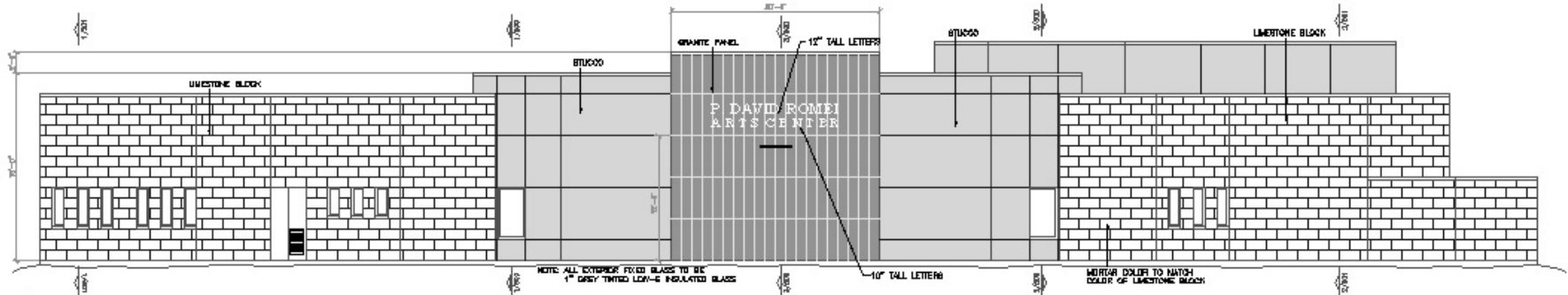

2 SOUTH ELEVATION
REF. NONE

1/4"=1'-0"

LIVESTONE BLOCK 4" THICK X 12" HIGH X 16" LONG

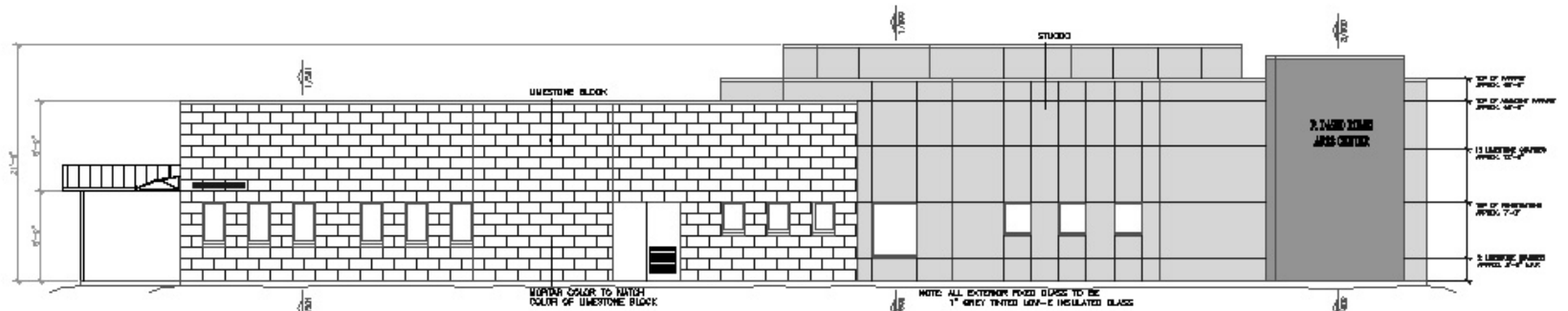

3 SOUTHWEST ELEVATION
REF. NONE

1/4"=1'-0"

Foundation

The geotechnical engineer for the project determined that because of very poor soil conditions, over 50 piers were needed each at a depth of nearly 18 feet to support this structure. The entire site was levelled and backfilled in three six inch lifts with lime stabilized select fill.



Design Loads

1. The foundation has been designed according to the requirements of the **International Building Code**.

Design Wind Speed = 90 mph.

Earthquake Zone 0

2. The foundation has been designed for the following **live loads**:

Roof = 20 psf

Floor Slabs on Grade = 500 psf

Suspended Floor Slabs = 100 psf

3. Drilled footing design is based upon an **allowable bearing pressure of 7500 psf for dead loads and 11,250 psf for dead plus live load.**

- WIND UPLIFT
- DEAD LOAD
- LATERAL FORCE
- REACTION FORCE

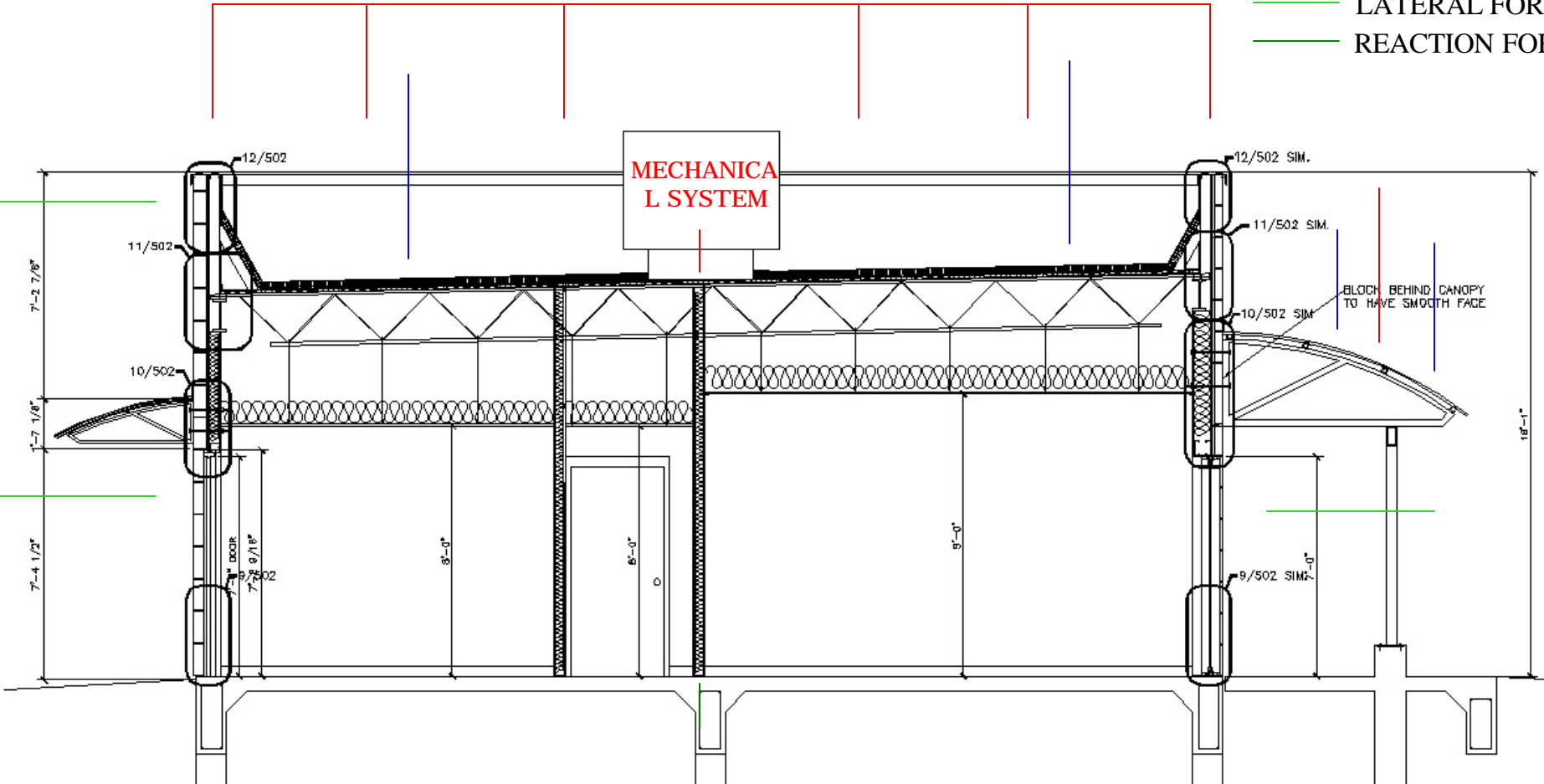

1 SECTION @ CONFERENCE
REF. 1/201

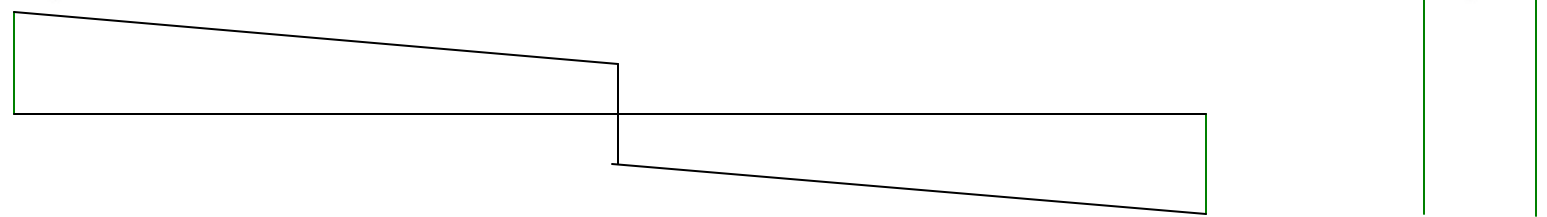

1/2"=1'-0"

NOTE: ALL SLAB TO BEAR A MINIMUM OF 4" ON BEAM

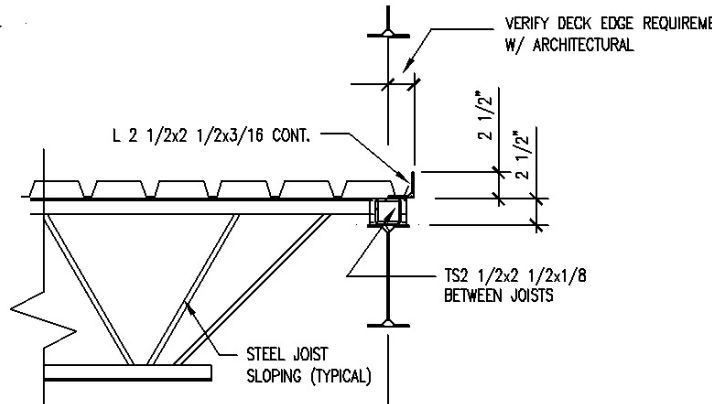
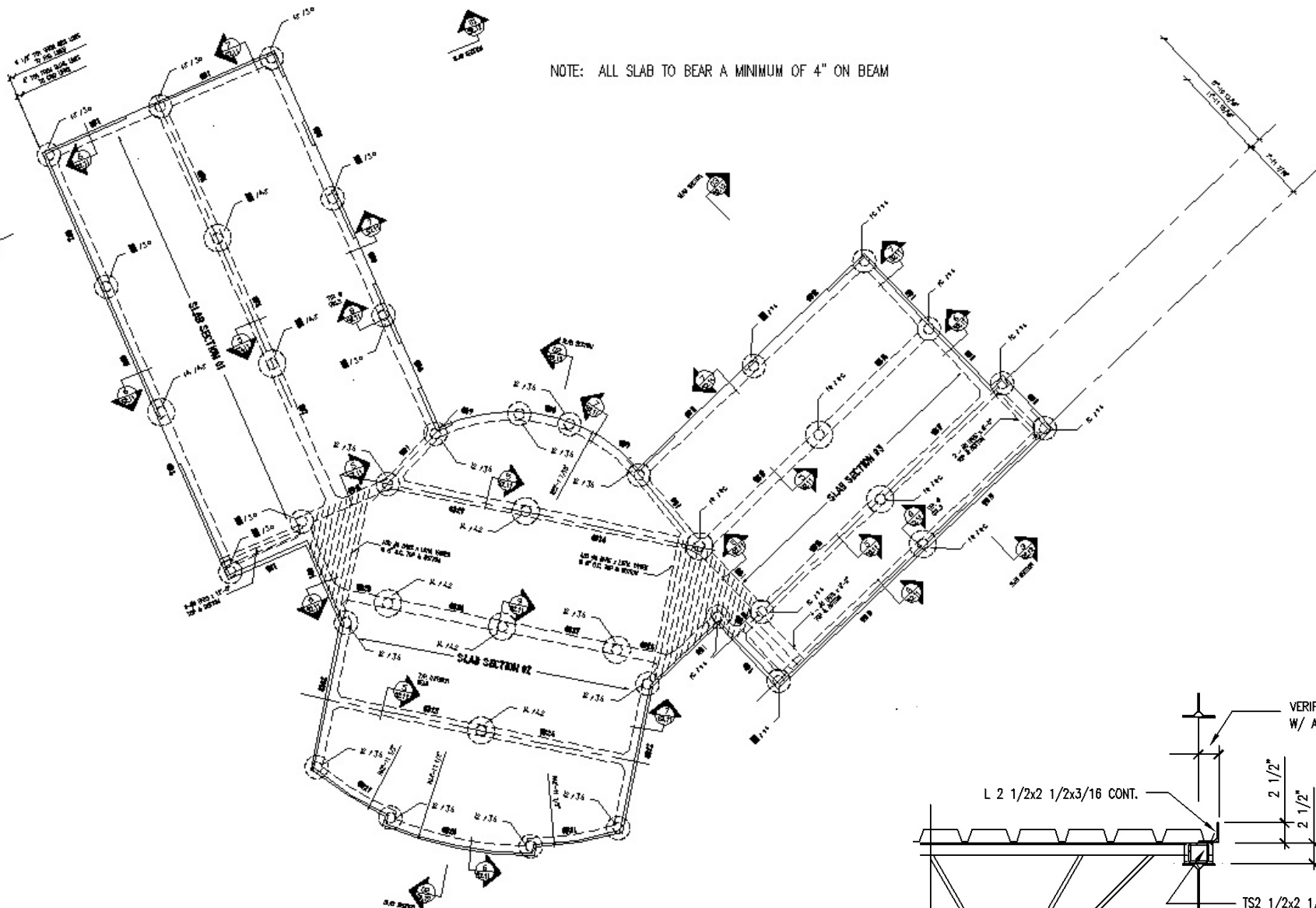

20 SECTION - INTERIOR BM. LINE

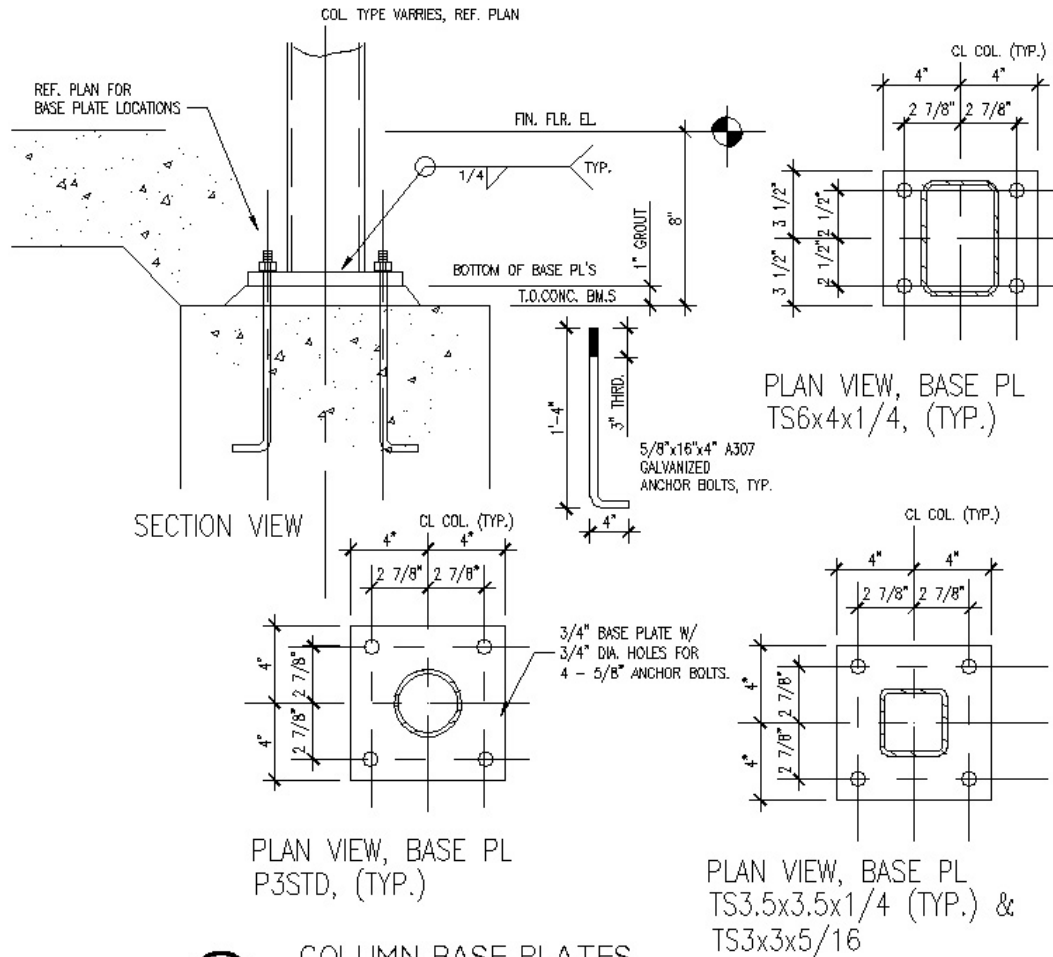

7 COLUMN BASE PLATES

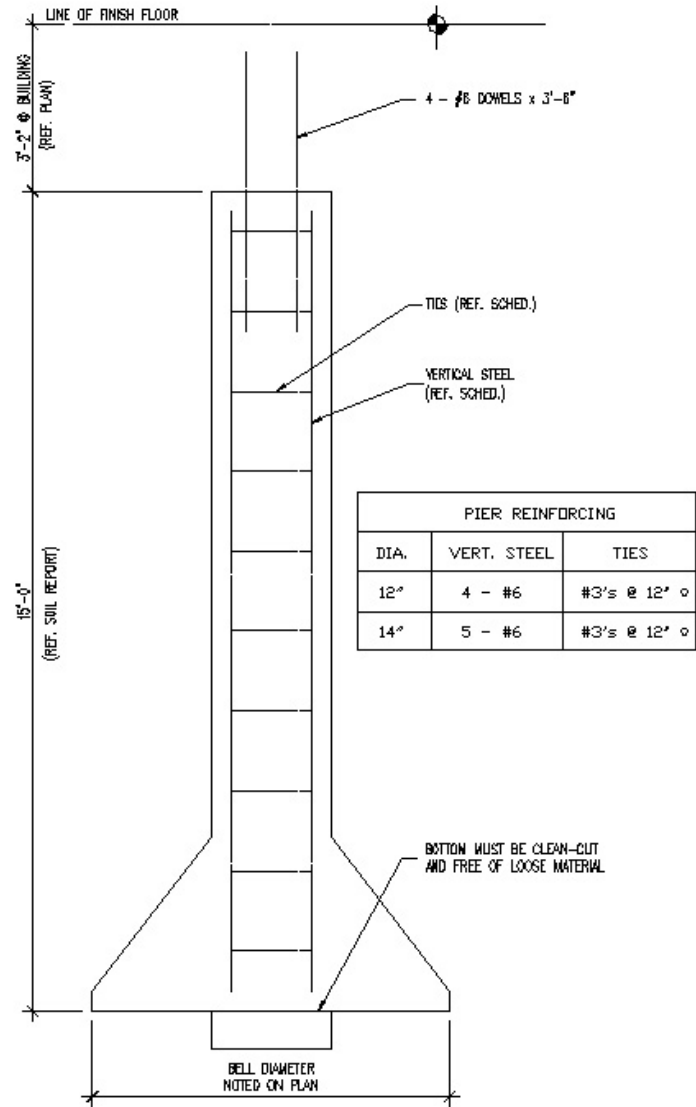

1 TYPICAL DRILLED PIERS

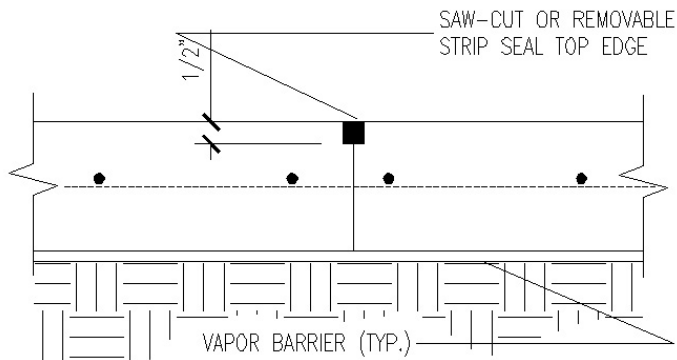

6

TYP. SLAB CONTROL JOINT

REF. PLAN FOR LOCATIONS NOTED CJ

METAL KEY

TOOL JOINT 1/2" SEAL

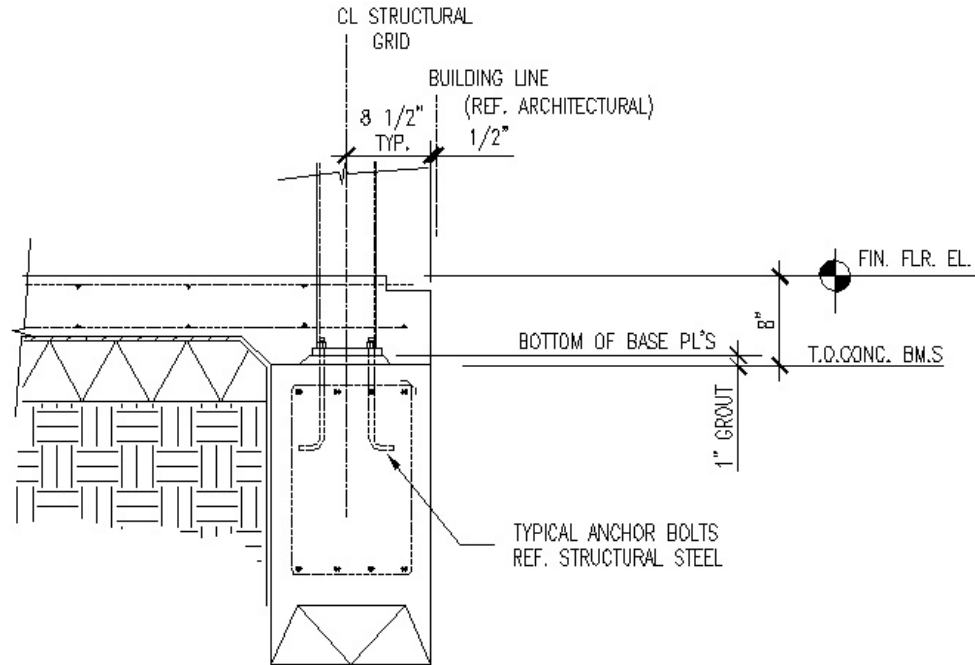

8

SECTION - GRD. BM. @ COL.

Structural Steel



1. Design, fabrication, and erection of structural steel shall be in accordance with AISC Specifications, latest edition. All cold rolled structural shapes shall meet the requirements of the AISI, latest edition.
2. All structural shapes and plates shall conform to ASTM A36-81a. Structural tubing shall conform to ASTM A501 and have a minimum yield point of 46 KSI. Structural pipe shall conform to ASTM A53.
3. Unless shown otherwise, connections shall be shop welded and field bolted and shall be in accordance with the standards of the AISC. Bolts, including anchor bolts, shall be ASTM A307 or ASTM A325 as required by the specific connection detail.
4. Splicing of structural steel members is prohibited without prior review by the structural engineer as to type and location of splice. Splices shall be detailed on the shop drawings.
5. Burning and/or torch cutting of holes in members is expressly prohibited.
6. All welds shall be made with A-233 Class E-70 Series electrode or by submerged arc welding S.A.W. 2 in accordance with the Structural Welding Code AWS D1.1-96.
7. All structural steel shall be shop painted with a rust inhibiting primer to a 2 mil dry film thickness. Exclude paint from areas within 2 inches of field welded connections. Field touch-up painting shall be accomplished on those areas when welding operations are complete.
8. Provide temporary bracing for accurate plumbing, and to resist all wind and construction loads. Contractor shall maintain temporary bracing until all permanent lateral bracing (including diagonal bracing, moment connections, and/or walls) are installed and approved.
9. All openings through roof and floor decks are shown. Openings of 6" or less require no additional framing. Openings larger than 6" shall be framed with the typical size finish edge angle or as shown on Drawings. Additional openings shall be with the Architect's approval.

Structural Steel

Steel Joists and Joist Girders

1. All steel joists and joist girders shall conform to specifications of the Steel Joist Institute, applicable series. Top chords shall be angles or tee sections. Bridging shall be rigid cross-type or horizontal type as indicated on the drawings. Bridging shall be continuous and terminate at masonry walls, concrete walls or steel beams.
2. Unless otherwise shown, weld all joists to steel bearing seats with 1/8" fillet welds, one inch long on each side of the seats.
3. **SPECIAL JOIST DESIGN LOADS:** The joists supporting the parking deck shall be designed for 150 psf DL + LL uniform load; or 50 psf DL uniform load and 2 - 2000 lb concentrated loads spaced 5' apart placed at any location along the span of the joists.



Finish



Interior

