

YOUR MOMMA'S GROUP

ARCH 631

BRYAN O'SULLIVAN

JOSH GUERRA

JEFF CHAPWOMAN

JASON GEORGE

STEVE NGUYEN

PROJECT REQUIREMENTS

Must support one team member and another person

Platform required to be at least 30mm from ground

Support both people with a lateral load applied by the instructor

A minimum of 3 types of stabilizing systems must be used

Demonstration of structural braces to follow

BUILDING SEQUENCE : COLUMNS

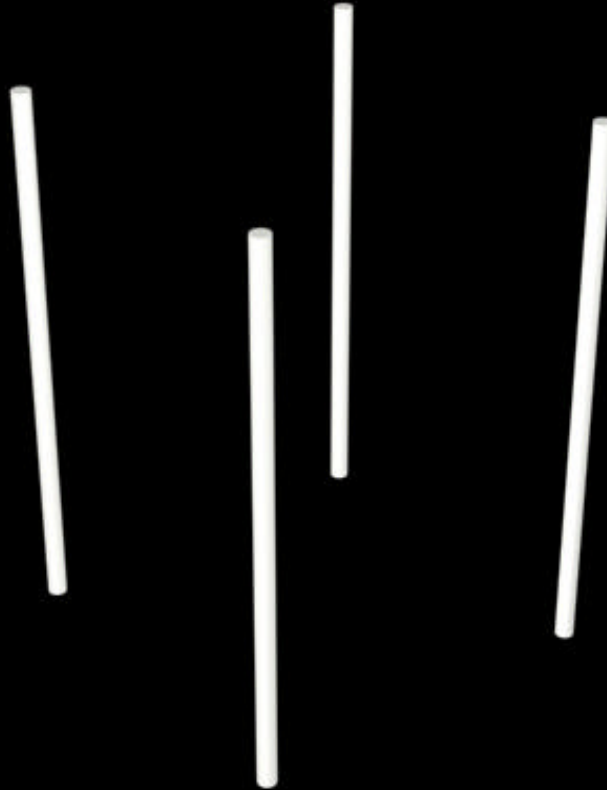

BUILDING SEQUENCE : COLUMNS



Josh and Steve assist Jeff in cutting a column.

BUILDING SEQUENCE : JOISTS AND DECKING

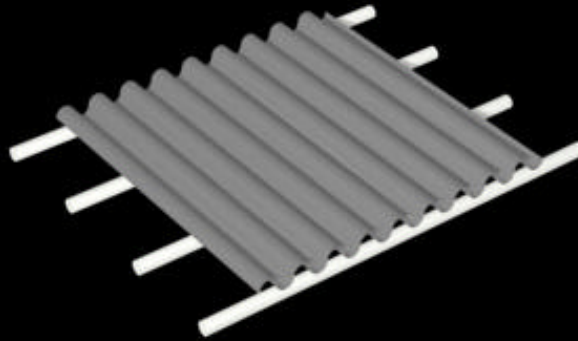

BUILDING SEQUENCE : JOISTS AND DECKING



Steve measures the decking.

BUILDING SEQUENCE : JOISTS AND DECKING



Bryan and Jeff measure the drill holes.

BUILDING SEQUENCE : JOISTS AND DECKING



Josh and Steve drilling through the decking and a joist.

BUILDING SEQUENCE : JOISTS AND DECKING



Jason drills through a joist as Bryan and Steve look on.

BUILDING SEQUENCE : DIAPHRAGM

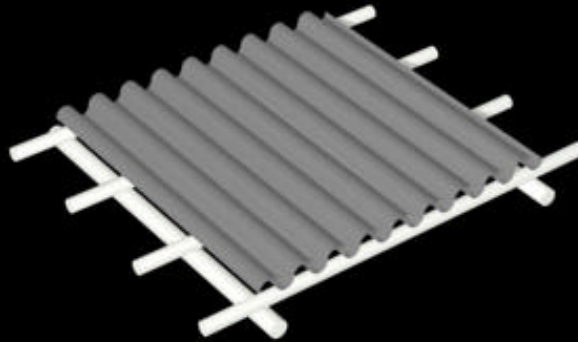

BUILDING SEQUENCE : DIAPHRAGM



Josh bolts a beam through joists to the decking.

BUILDING SEQUENCE : DIAPHRAGM AND COLUMNS

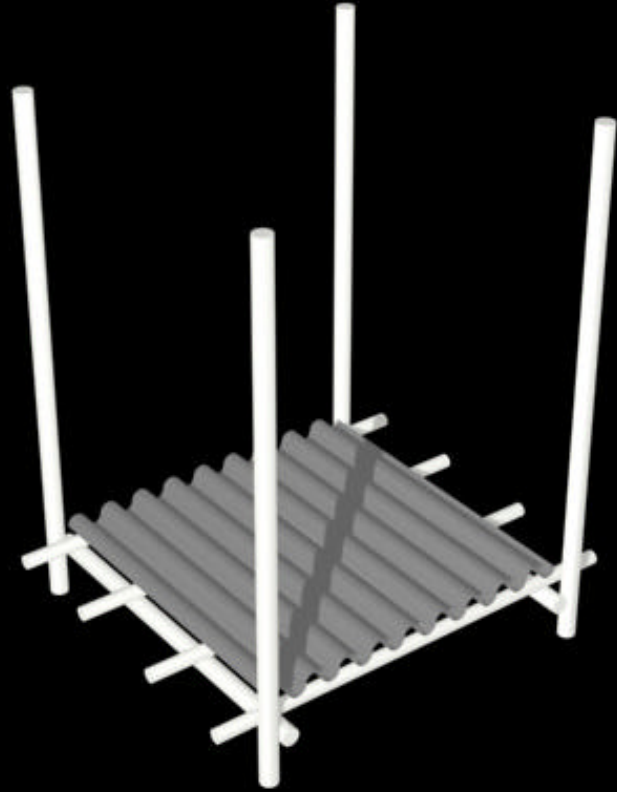

BUILDING SEQUENCE : DIAPHRAGM AND COLUMNS



Jason admires Josh and Bryan attaching columns to the diaphragm.

BUILDING SEQUENCE : DIAPHRAGM AND COLUMNS



The assembled base and columns. WHOA! Look at that rotation Steve!

BUILDING SEQUENCE : FRAME

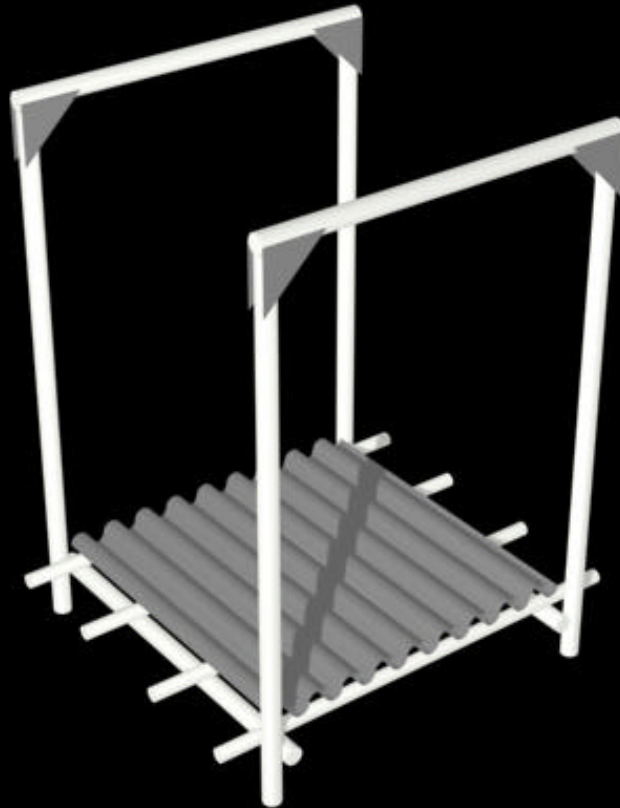

BUILDING SEQUENCE : FRAME



Hey Bryan! Check out that rigid connection. Pretty sharp, eh?

BUILDING SEQUENCE : DIAGONAL BRACING

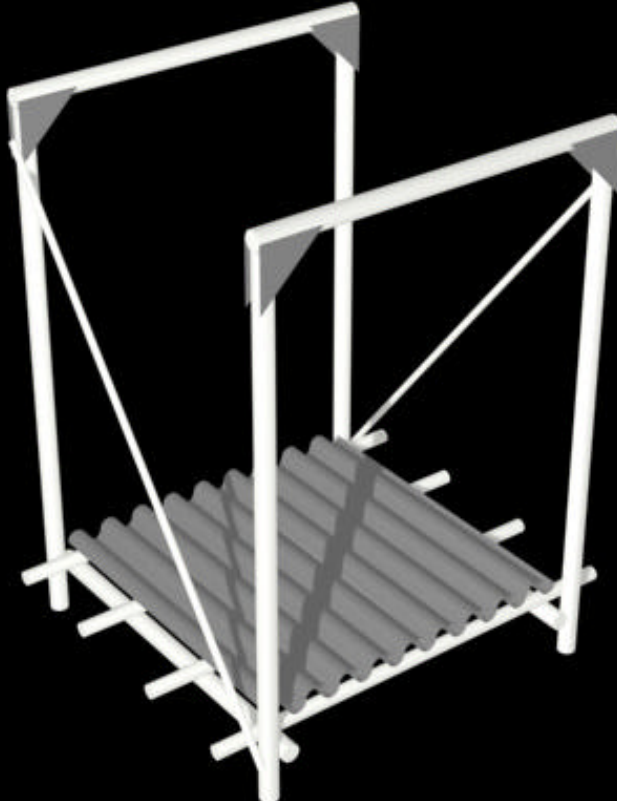

BUILDING SEQUENCE : DIAGONAL BRACING



Lateral bracing provided by Dr. Pepper. Be you!

BUILDING SEQUENCE : STABILIZING BEAMS

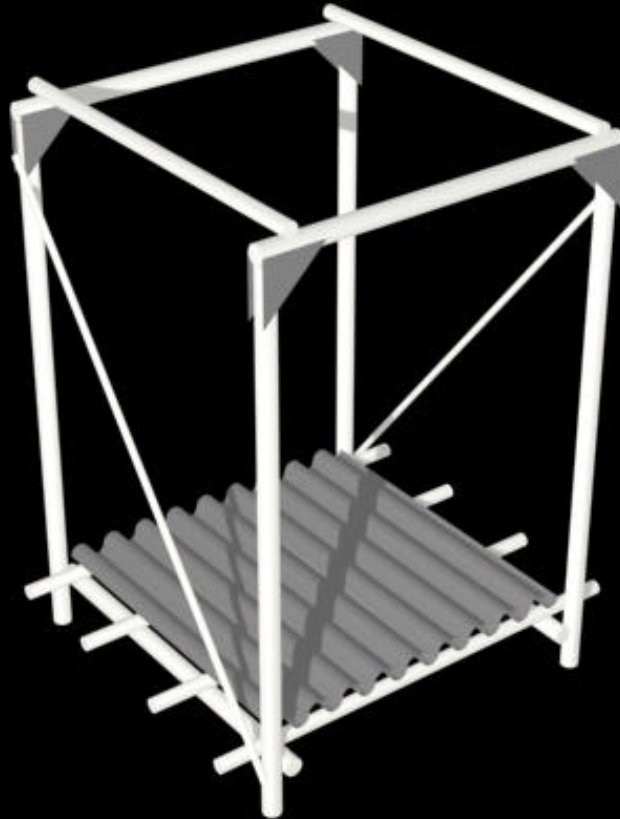

BUILDING SEQUENCE : STABILIZING BEAMS



Josh, Steve and Bryan attach those stabilizing beams.

BUILDING SEQUENCE : STABILIZING BEAMS



The final connection is made. Great job guys. Now lets test it!

BUILDING SEQUENCE : THEORETICAL TESTING

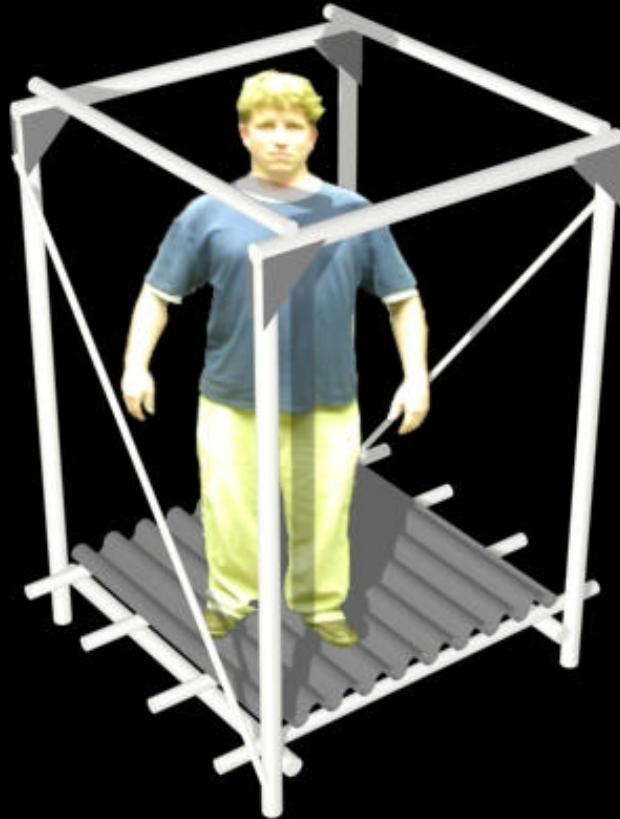

“I could jump up and down on this all day!”

BUILDING SEQUENCE : TESTING



It passes the strenuous “Josh” test.

BUILDING SEQUENCE : TESTING



Bryan's additional 73 pounds were NO MATCH for the frame!.

BUILDING SEQUENCE : TESTING



It even handles the ultimate “Josh and Bryan and Steve” test. Dare we do more?!

BUILDING SEQUENCE : TESTING



Impossible! It passes the impossible “Josh and Bryan and Steve and Jeff” test!

ANALYSIS OF THE REACTION FORCES

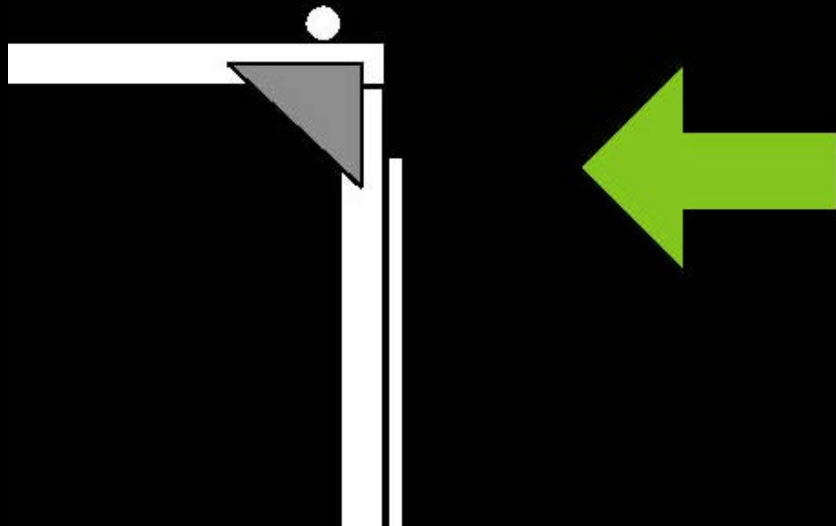

LATERAL LOADS

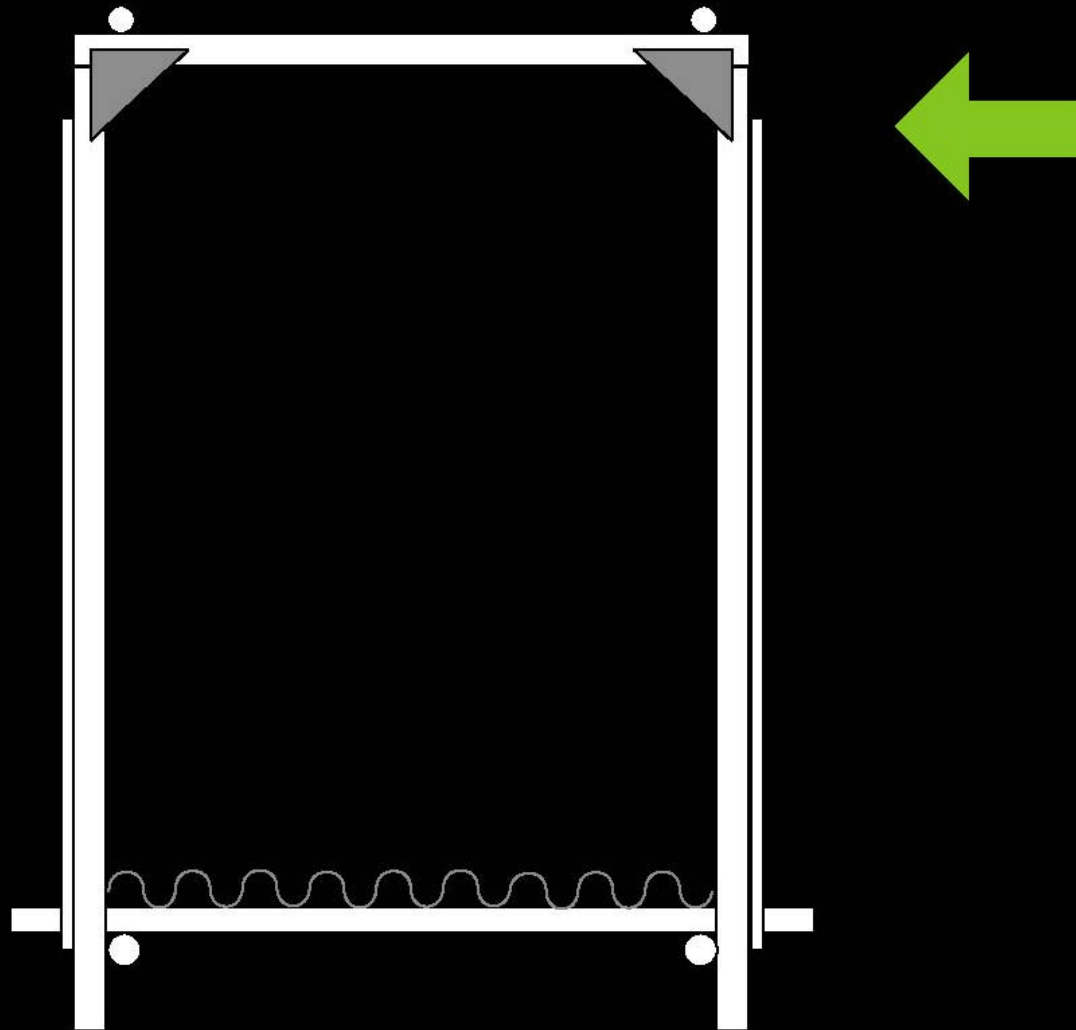

Reaction of the rigid frame connections

LATERAL LOADS

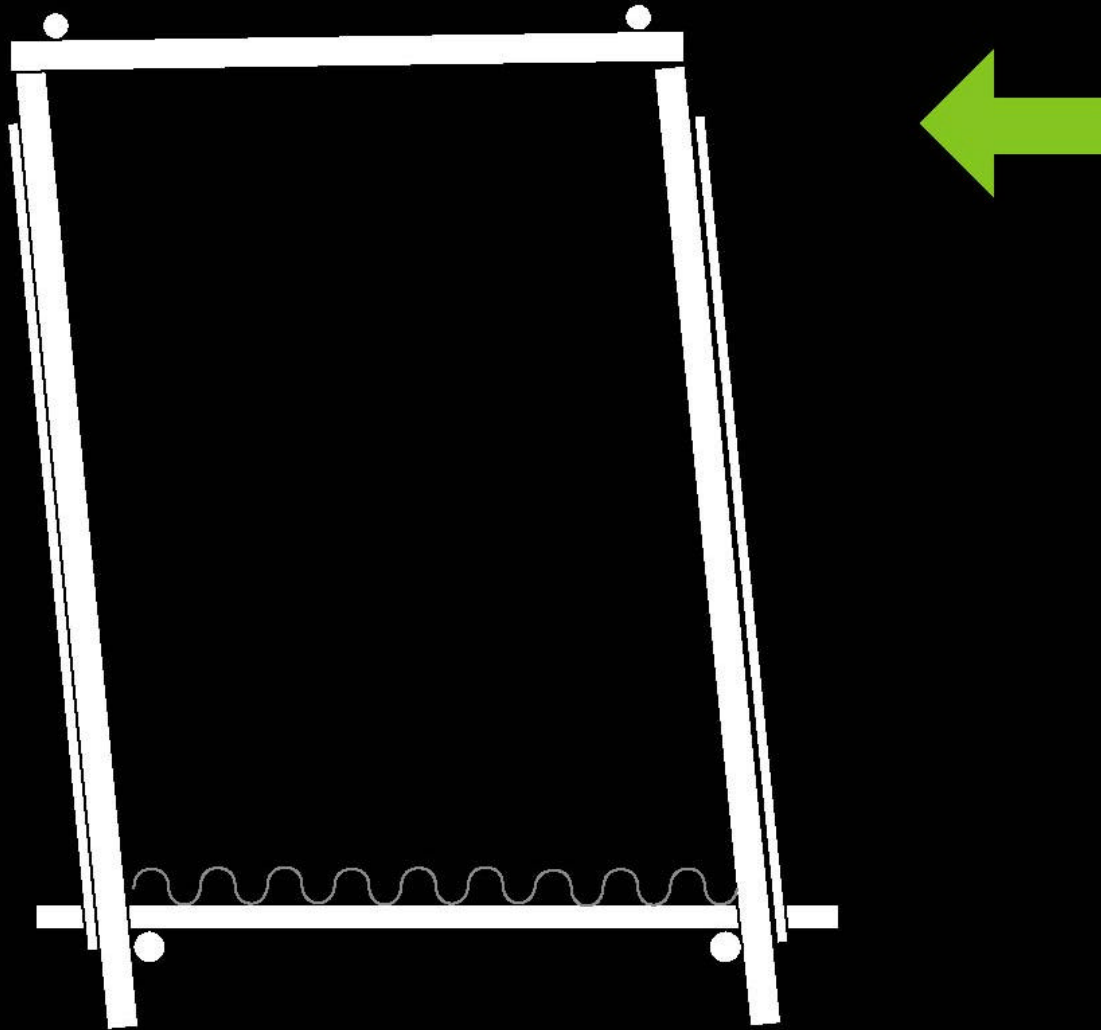

Reaction without rigid frame connections

LATERAL LOADS

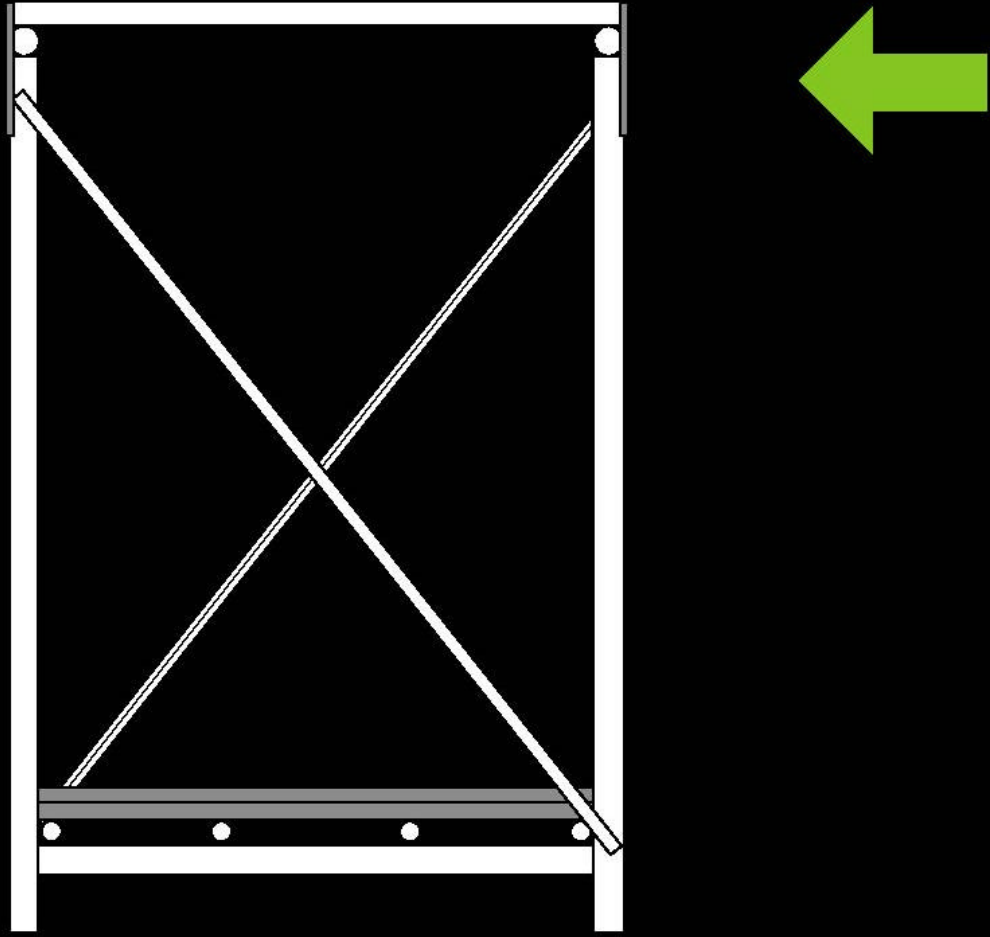

Reaction with cross bracing

LATERAL LOADS

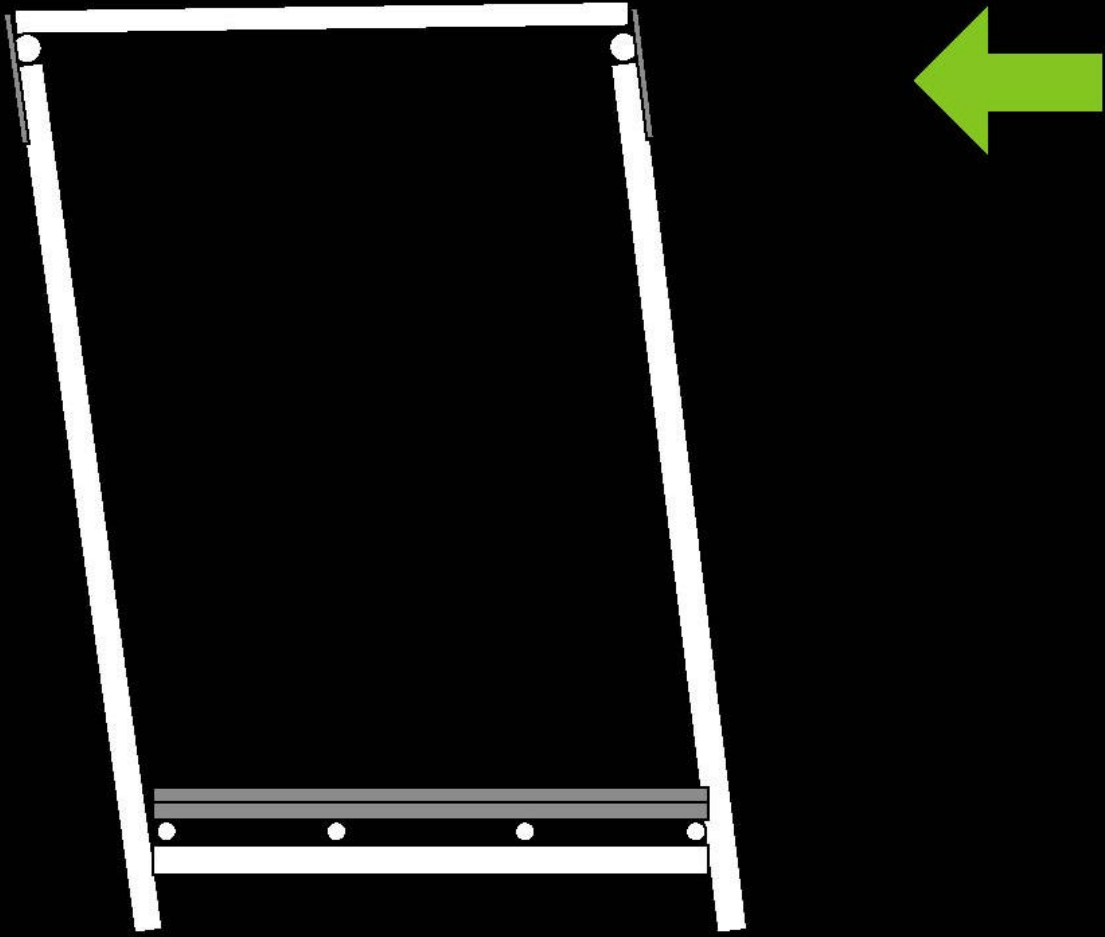

Reaction without cross bracing

LATERAL LOADS

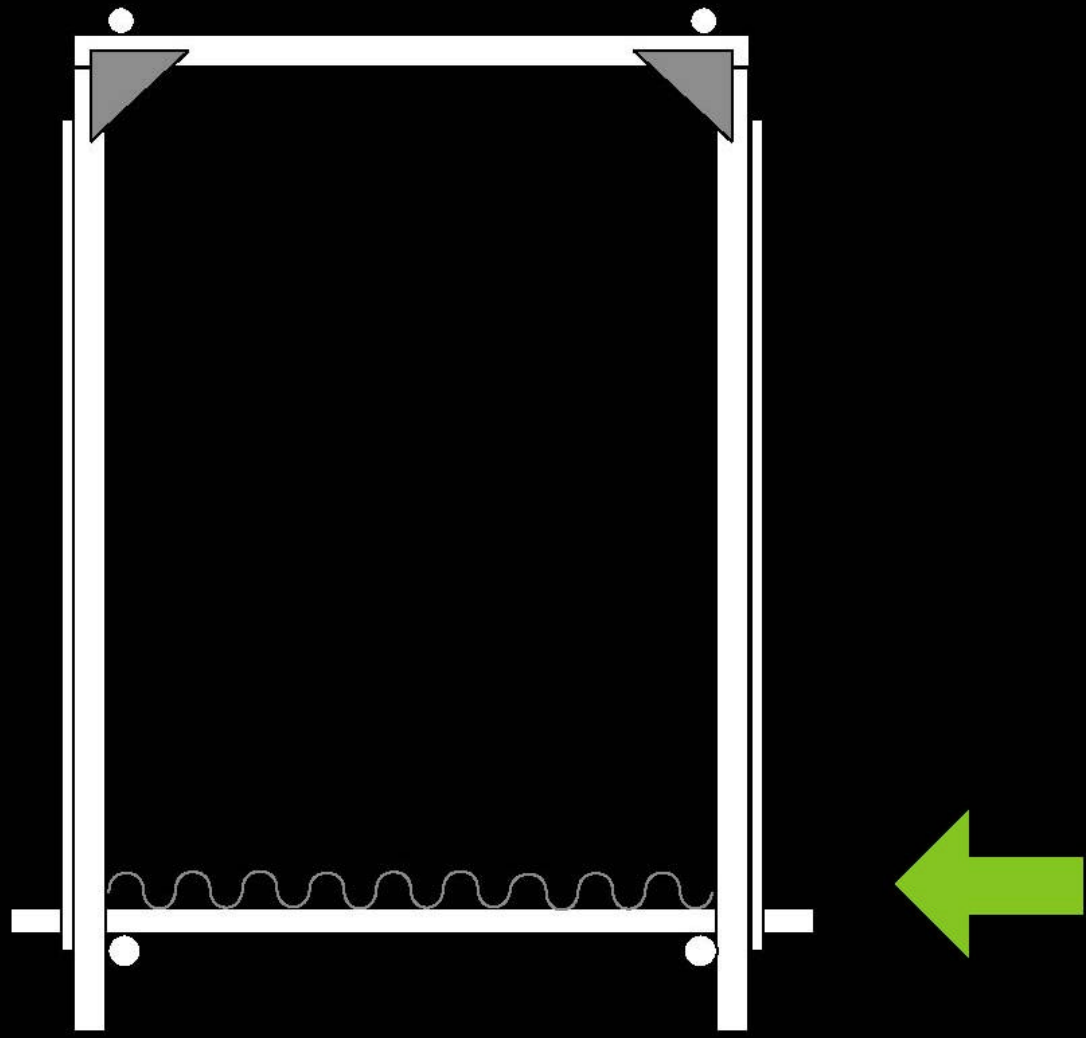

Reaction with diaphragm

LATERAL LOADS

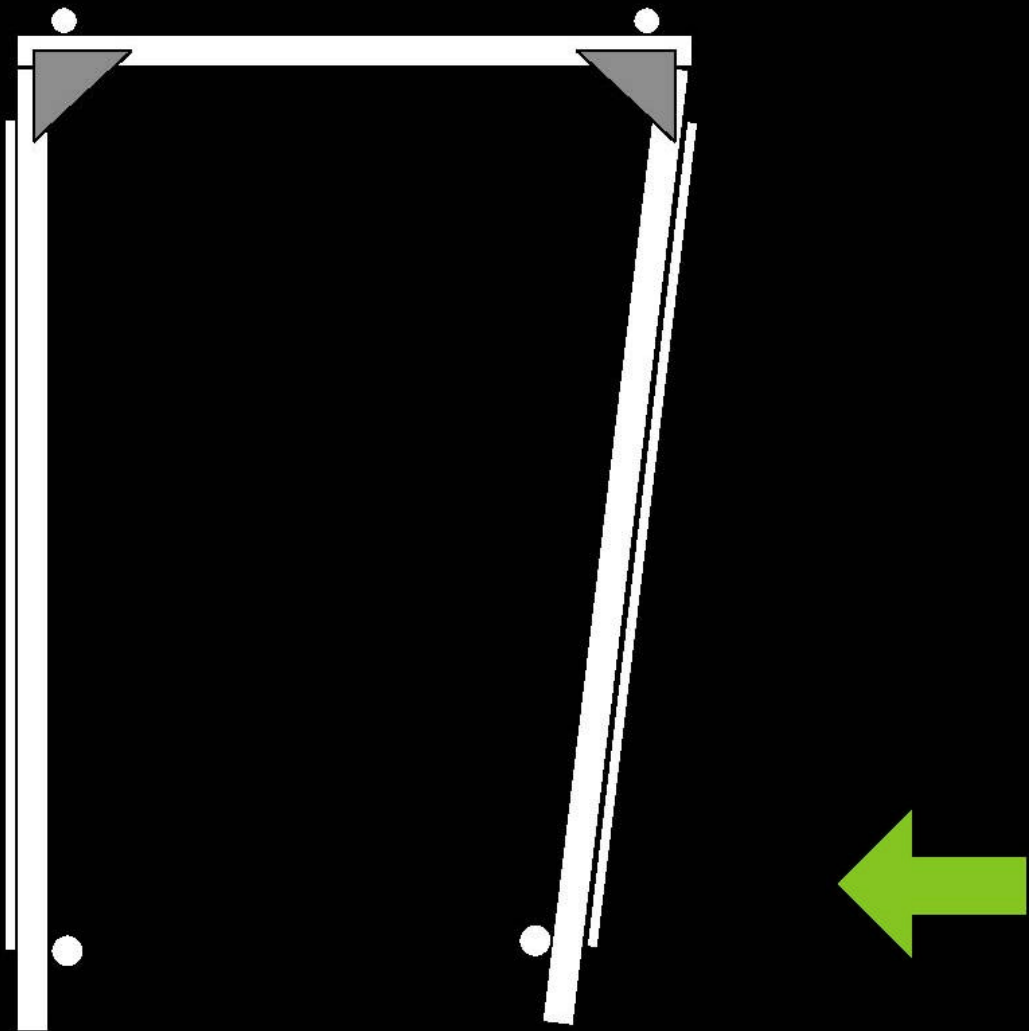

Reaction without diaphragm

VERTICAL LOAD

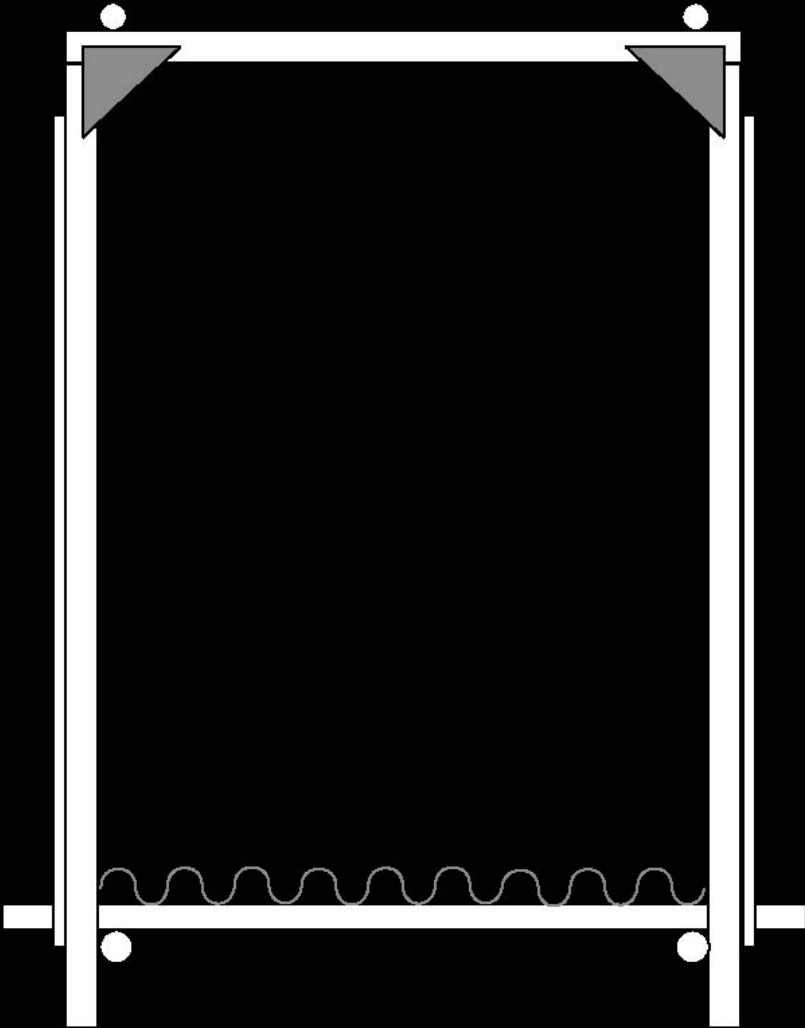

No load applied

VERTICAL LOAD

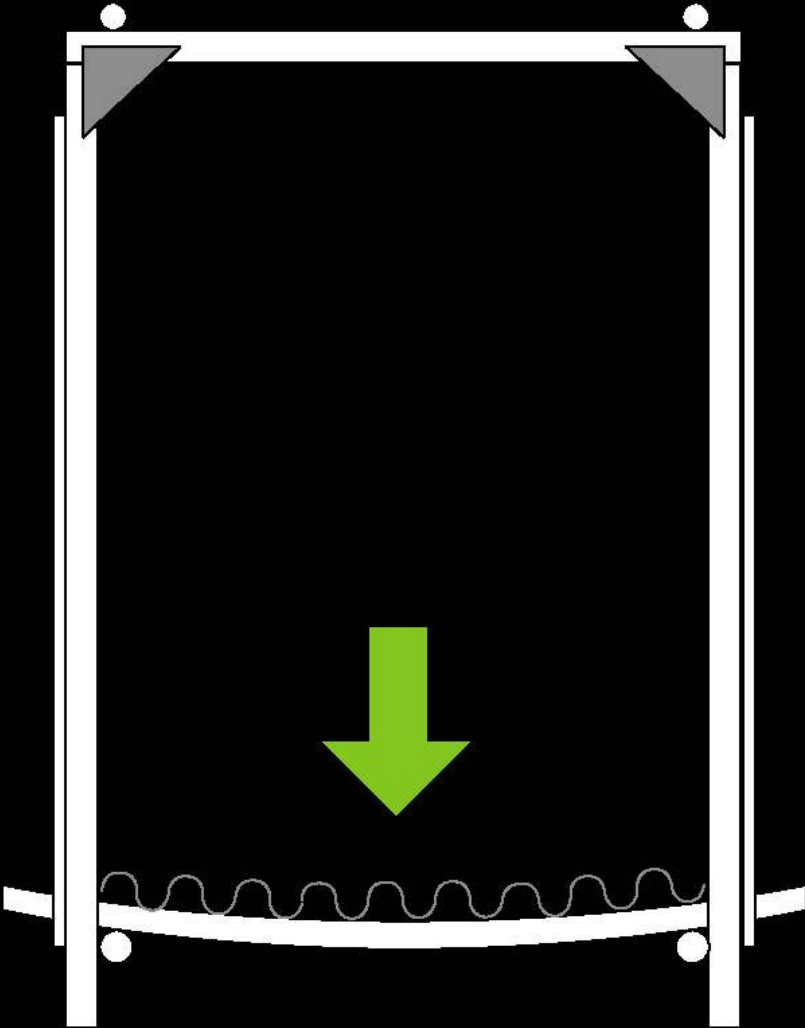

Reaction under applied load.

Fin