

APPLIED ARCHITECTURAL STRUCTURES:
STRUCTURAL ANALYSIS AND SYSTEMS

ARCH 631

DR. ANNE NICHOLS

FALL 2012

lecture
five

trusses
& columns



www.nyc-architecture.com

Columns & Trusses 1
Lecture 5

Applied Architectural Structures
ARCH 631

F2010abn

Trusses

- ancient (?) wood
- 1800's analysis
- efficient
- long spans



Columns & Trusses 2
Lecture 4

Architectural Structures III
ARCH 631

F2007abn

Trusses

- comprised of straight members
- geometry with triangles is stable
- loads applied only at joints

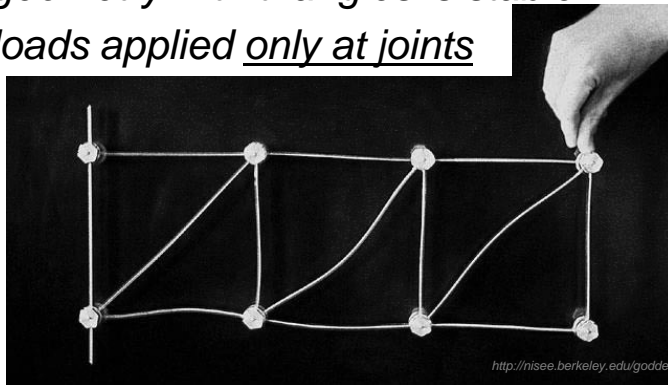

http://nisee.berkeley.edu/godden

Columns & Trusses 3
Lecture 4

Architectural Structures III
ARCH 631

F2007abn

Trusses

- 2 force members
 - compression
 - tension

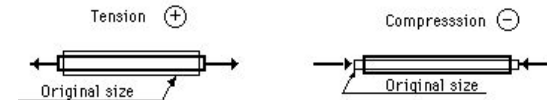

- 3 members connected by 3 joints
- 2 more members need 1 more joint

$$b = 2n - 3$$

$$(n = 2j - 3)$$

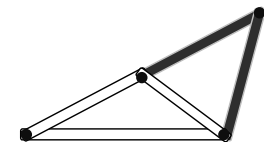

Columns & Trusses 4
Lecture 4

Architectural Structures III
ARCH 631

F2007abn

Truss Analysis

- visualize compression and tension from deformed shape

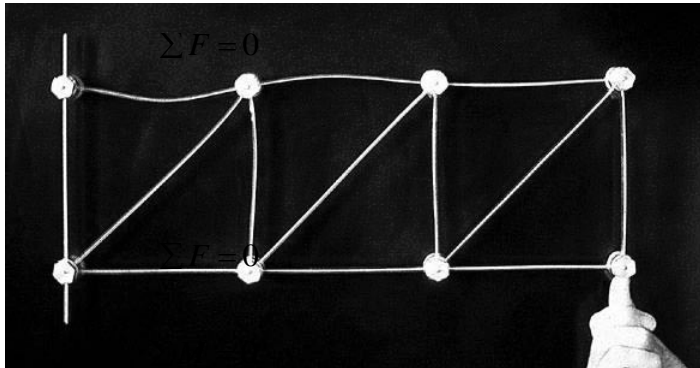

<http://nisee.berkeley.edu/godden>

Columns & Trusses 5
Lecture 4

Architectural Structures III
ARCH 631

F2007abn

Truss Analysis

- Method of Joints
 - $\sum F = 0$
- Method of Sections
 - $\sum F = 0$
 - $\sum M = 0$
- Graphical Methods
- all rely on equilibrium
 - of bodies
 - internal equilibrium



<http://nisee.berkeley.edu/godden>

Columns & Trusses 6
Lecture 4

Architectural Structures III
ARCH 631

F2007abn

Truss Connections

- “pins”
 - can't resist rotation

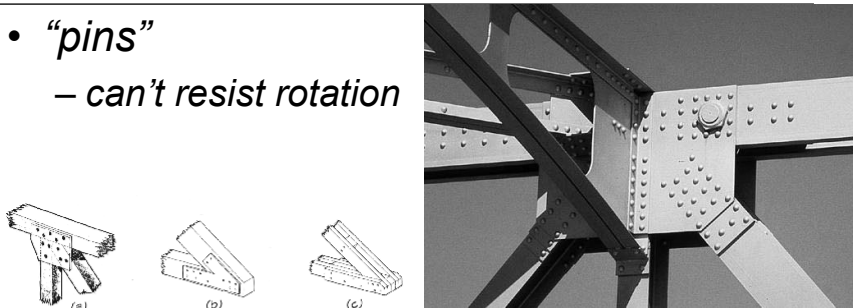

<http://nisee.berkeley.edu/godden>

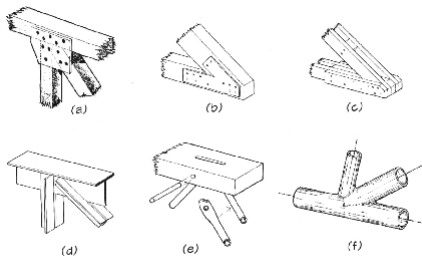

Figure 4.8: Truss joints.

Columns & Trusses 7
Lecture 4

Architectural Structures III
ARCH 631

F2007abn

Trusses

- require lateral bracing
- consider buckling
- indeterminate trusses
 - extra members
 - solvable with statics
 - cables can't hold compression
 - displacement methods
 - elastic elongation
 - too few members, unstable

<http://nisee.berkeley.edu/godden>



One Transamerica Plaza: SOM, 1964

F2007abn

Columns & Trusses 8
Lecture 4

Architectural Structures III
ARCH 631

Space Trusses

- pyramid
- tetrahedron

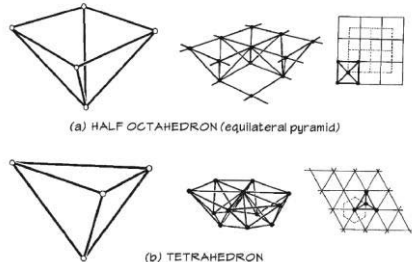
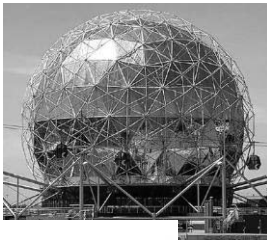

Columns & Trusses 9
Lecture 4

Architectural Structures III
ARCH 631

<http://nisee.berkeley.edu/godden>
F2007abn

Space Trusses

- connections
- supports

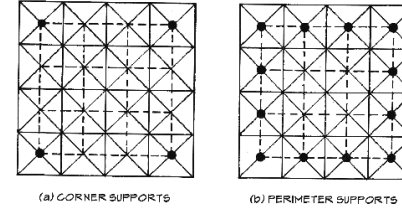
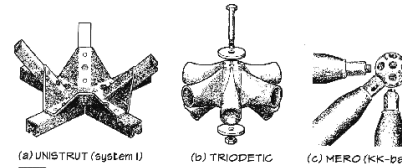

Columns & Trusses 10
Lecture 4

Architectural Structures III
ARCH 631

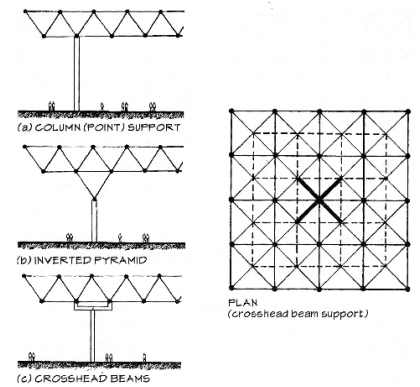

F2007abn

Crystal Cathedral, Johnson 1980

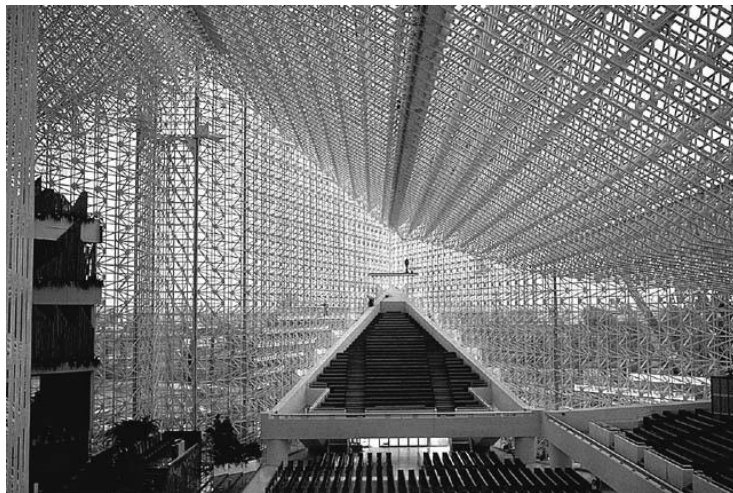

Columns & Trusses 11
Lecture 4

Architectural Structures III
ARCH 631

<http://nisee.berkeley.edu/godden>

F2007abn

Expo 70 Festival Plaza



- Tange & Kamiya 1970

Columns & Trusses 12
Lecture 4

Architectural Structures III
ARCH 631

F2007abn

Jacob K. Javits Convention Center

- I.M. Pei 1980



Columns & Trusses 13
Lecture 4
Architectural Structures III
ARCH 631
F2007abn

Jacob K. Javits Convention Center

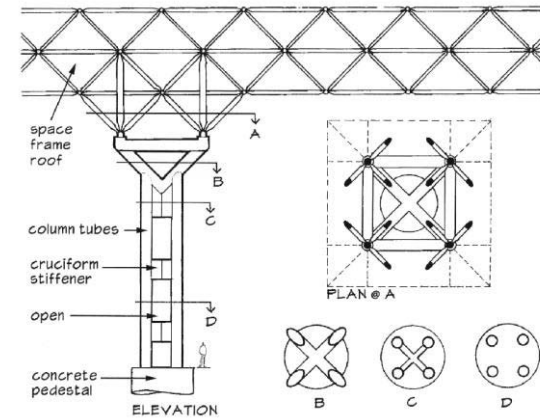

Figure 5.10: Javits Center, column details: (a) elevation, and (b) through (d) plan sections.

Columns & Trusses 14
Lecture 4

Architectural Structures III
ARCH 631

F2007abn

Louvre Museum Addition, Pei 1989



Paris 2002/09, Carol at the Louvre Entrance

Columns & Trusses 15
Lecture 4
Architectural Structures III
ARCH 631
F2007abn

Louvre Museum Addition, Pei 1989



www.GreatBuildings.com

Columns & Trusses 16
Lecture 4

Architectural Structures III
ARCH 631

F2007abn

Truss Design

- variables
 - spans
 - depths
 - length of members
 - spacing
 - transverse beam spacing
 - pattern
 - materials; size & strength efficiency



Trusses

- common designs

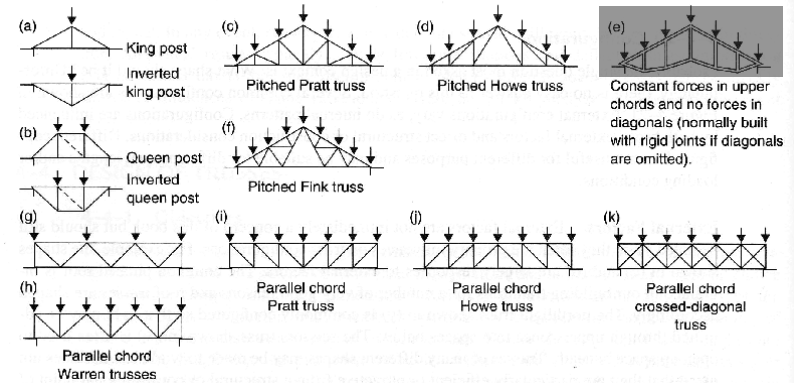

Trusses

- common designs

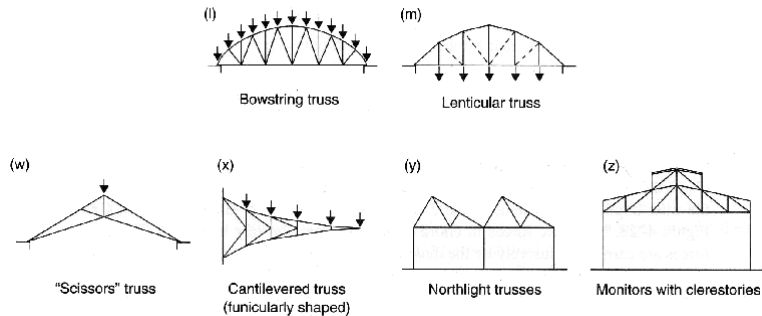

Truss Configurations

- external factors
 - roof form
 - openings
- basic forms
 - symmetrical loading
 - maximum bending
 - cables in tension only

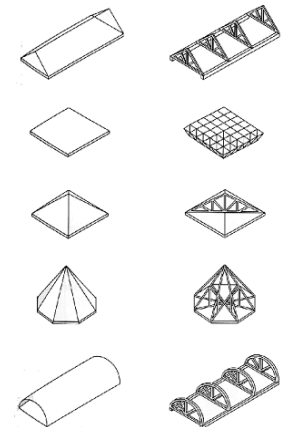

Truss Configurations

- *parallel chords*
 - verticals common
 - longer members in tension
 - often cross members - indeterminate
- *funicular shapes*
 - efficient
 - similar sized forces
 - some zero force

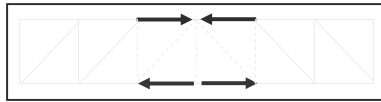

Bridges and Tunnels of Allegheny County, PA
© 2000 Bruce S. Criddlebaugh

Columns & Trusses 21
Lecture 4

Architectural Structures III
ARCH 631

F2007abn

Truss Configurations

- *special shapes*
 - *Vierendeel*
 - “*frame*”
- *depth*
 - depends on loads, span
 - rules of thumb, charts
- *structurally*
 - tension members can have holes!
 - compression members can buckle
 - 3D trusses stable



<http://nisee.berkeley.edu/godden>



Columns & Trusses 22
Lecture 4

Architectural Structures III
ARCH 631

F2007abn

Tools – Multiframe

- *in computer lab*

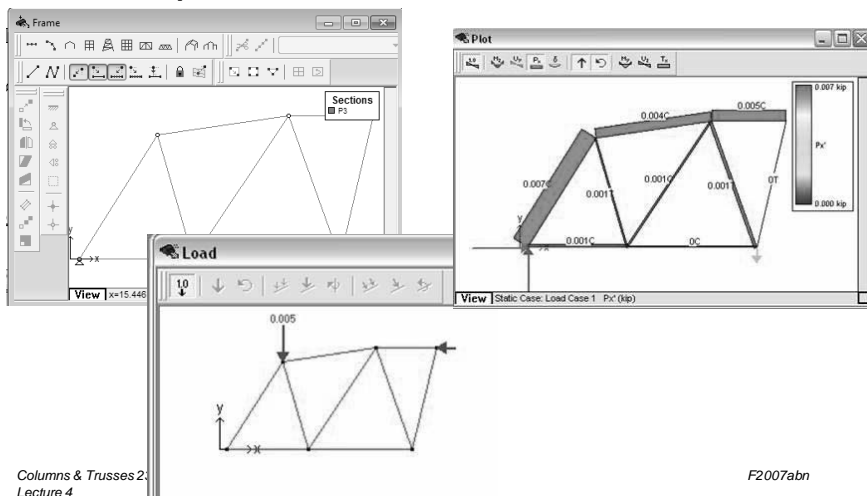

Columns & Trusses 23
Lecture 4

F2007abn

Tools – Multiframe

- *frame window*
 - define truss members
 - or pre-defined truss
 - select points, assign supports
 - select members, assign section & assign pin ends
- *load window*
 - select points, add point load

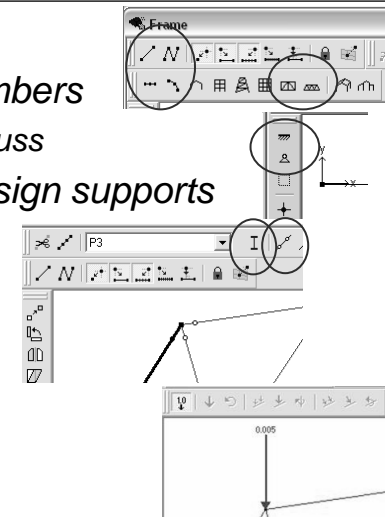

Columns & Trusses 24
Lecture 4

Architectural Structures III
ARCH 631

F2007abn

Tools – Multiframe

- to run analysis choose
 - Analyze menu
 - Linear
- plot
 - choose options
- results
 - choose options

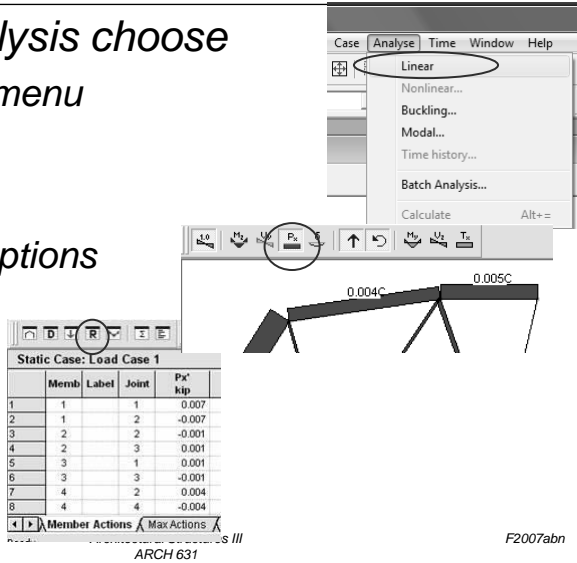

Columns & Trusses 25
Lecture 4

ARCH 631

F2007abn

Columns

- compression members
- column behavior is length dependant
 - short: crush
 - long: buckle (sudden) in slender direction
 - end restraints
- bearing walls
 - continuous in one direction
 - can resist lateral forces

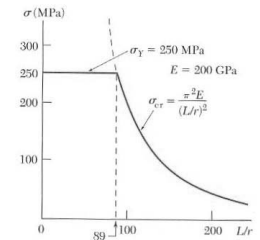

Fig. 10.9

F2007abn

Columns & Trusses 26
Lecture 4

Architectural Structures III
ARCH 631

Columns

- column buckling

crushing

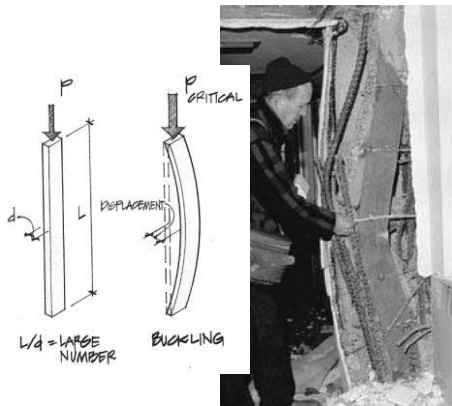

Columns & Trusses 27
Lecture 4

Architectural Structures III
ARCH 631

F2007abn

Columns

- stability
 - stable equilibrium
 - $P < P_{cr}$
 - neutral equilibrium
 - $P = P_{cr}$
 - unstable equilibrium
 - $P > P_{cr}$

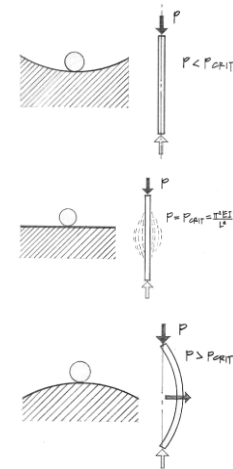

Columns & Trusses 28
Lecture 4

Architectural Structures III
ARCH 631

F2007abn

Buckling Load

- related to deflected shape ($P\Delta$)
- shape of sine wave
- Euler's Formula
- I minimum

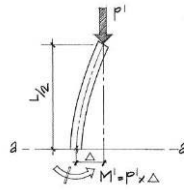

$$P_{critical} = \frac{\pi^2 EI_{min}}{(L)^2}$$



Figure 9.3 Leonhard Euler (1707–1783).

- stiffness related to E , I , & L

Critical Stress

- short columns

$$f_{critical} = \frac{P_{actual}}{A} < F_a$$

- slenderness ratio = L_e/r (L/d)

- radius of gyration = $r = \sqrt{\frac{I}{A}}$

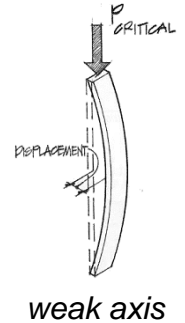

$$f_{critical} = \frac{P_{critical}}{A} = \frac{\pi^2 E A r^2}{A (L_e)^2} = \frac{\pi^2 E}{\left(\frac{L_e}{r}\right)^2}$$

$$P_{critical} = \frac{\pi^2 E A}{\left(\frac{L_e}{r}\right)^2}$$

Critical Stresses

- when a column gets stubby, F_y will limit the load
- real world has loads with eccentricity
- buckling for steel when $F_e < 0.44F_y$

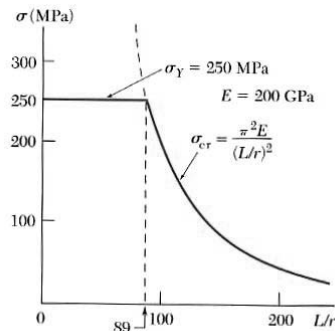

Fig. 10.9

$$\frac{KL}{r} > 4.71 \sqrt{\frac{E}{F_y}}$$

Columns

- end conditions affect shape
- effective length factor, k

	(a)	(b)	(c)	(d)	(e)	(f)
Buckled shape of column shown by dashed line						
Theoretical K value	0.5	0.7	1.0	1.0	2.0	2.0
Recommended design values when ideal conditions are approximated	0.65	0.80	1.0	1.2	2.10	2.0

Bracing

- bracing affects shape of buckle in one direction
- both directions should be checked!

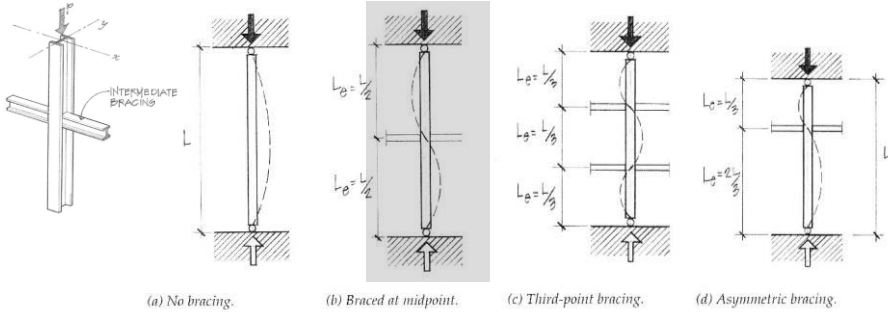

Columns & Trusses 33
Lecture 4

Architectural Structures III
ARCH 631

F2007abn

Columns and Walls

- bearing & shear

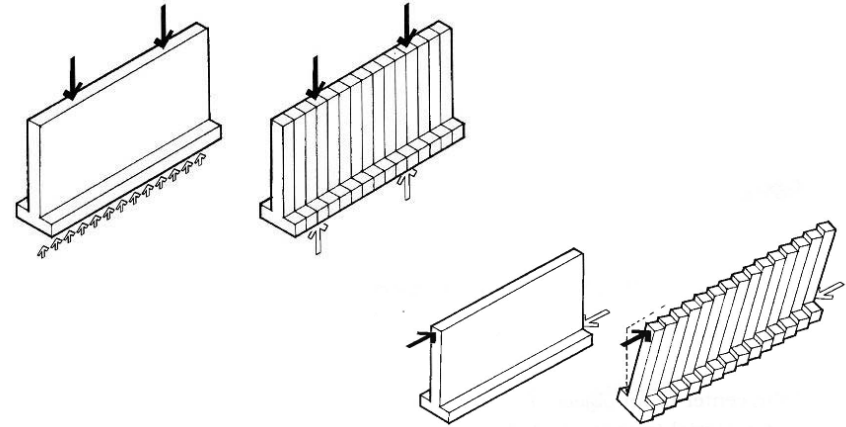

Columns & Trusses 34
Lecture 4

Architectural Structures III
ARCH 631

F2007abn

Columns

- typical cross sections

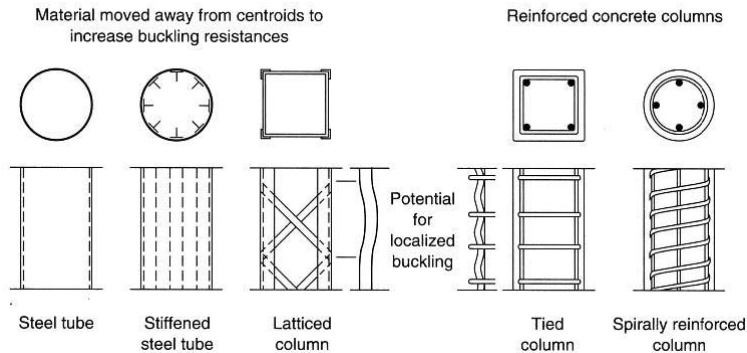

Columns & Trusses 35
Lecture 4

Architectural Structures III
ARCH 631

F2007abn

Centric & Eccentric Loading

- centric
 - allowable stress from strength or buckling
- eccentric
 - combined stresses

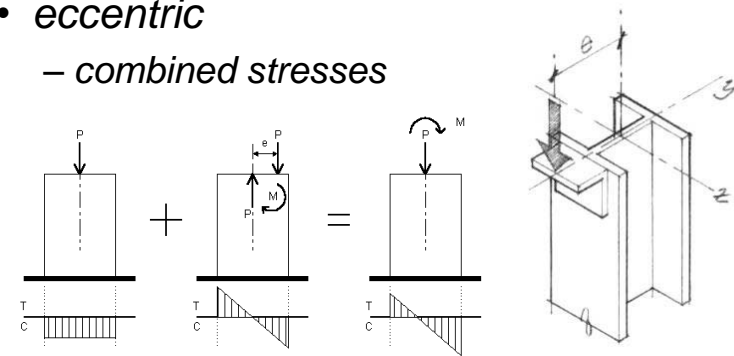

Columns & Trusses 36
Lecture 5

Architectural Structures III
ARCH 631

F2010abn

Combined Stresses

– axial + bending

$$f_{\max} = \frac{P}{A} + \frac{Mc}{I}$$

$$M = P \cdot e$$

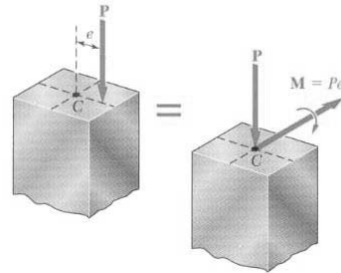

– design

$$f_{\max} \leq F_{cr} = \frac{f_{cr}}{F.S.}$$

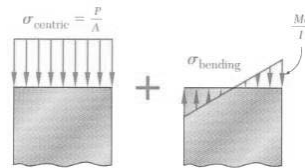

Columns & Trusses 37
Lecture 5

Architectural Structures III
ARCH 631

F2010abn

Column Materials

- wood
- steel
 - W sections can buckle about both axes
- concrete & masonry
 - compression primarily in concrete
 - reinforcement for bending



Columns & Trusses 36
Lecture 4

Architectural Structures III
ARCH 631

F2007abn