

Mechanics of Materials Primer

Notation:

<p>A = area (net = with holes, bearing = in contact, etc...)</p> <p>b = total width of material at a horizontal section</p> <p>d = diameter of a hole</p> <p>D = symbol for diameter</p> <p>E = modulus of elasticity or Young's modulus</p> <p>f = symbol for stress</p> <p>$f_{allowable}$ = allowable stress</p> <p>$f_{critical}$ = critical buckling stress in column calculations from $P_{critical}$</p> <p>f_v = shear stress</p> <p>f_p = bearing stress (see P)</p> <p>$F_{allowed}$ = allowable stress (used by codes)</p> <p>$F_{connector}$ = shear force capacity per connector</p> <p>I = moment of inertia with respect to neutral axis bending</p> <p>J = polar moment of inertia</p> <p>K = effective length factor for columns</p> <p>L = length</p> <p>L_e = effective length that can buckle for column design, as is ℓ_e, $L_{effective}$</p> <p>M = internal bending moment, as is M'</p> <p>n = number of connectors across a joint</p> <p>p = pitch of connector spacing</p> <p>P = name for axial force vector, as is P'</p> <p>P_{crit} = critical buckling load in column calculations, as is $P_{critical}$, P_{cr}</p> <p>Q = first moment area about a neutral axis</p>	<p>$Q_{connected}$ = first moment area about a neutral axis for the connected part</p> <p>r = radius of gyration or radius of a hole</p> <p>S = section modulus</p> <p>t = thickness of a hole or member</p> <p>T = name for axial moment or torque</p> <p>V = internal shear force</p> <p>y = vertical distance</p> <p>α = coefficient of thermal expansion for a material</p> <p>δ = elongation or length change</p> <p>δ_T = elongation due or length change due to temperature</p> <p>ε = strain</p> <p>ε_T = thermal strain (no units)</p> <p>ϕ = angle of twist</p> <p>γ = shear strain</p> <p>π = pi (3.1415 radians or 180°)</p> <p>θ = angle of principle stress = slope of the beam deflection curve</p> <p>ρ = name for radial distance</p> <p>σ = engineering symbol for normal stress</p> <p>τ = engineering symbol for shearing stress</p> <p>Δ = displacement due to bending</p> <p>ΔT = change in temperature</p> <p>\int = symbol for integration</p>
---	--

Mechanics of Materials is a basic engineering science that deals with the relation between externally applied load and its effect on deformable bodies. The main purpose of Mechanics of Materials is to answer the question of which requirements have to be met to assure STRENGTH, RIGIDITY, AND STABILITY of engineering structures.

Normal Stress

Stress that acts along an *axis* of a member; can be internal or external; can be compressive or tensile.

$$f = \sigma = \frac{P}{A_{net}} \quad \text{Strength condition: } f = \frac{P}{A_{net}} < f_{allowable} \text{ or } F_{allowed}$$

Shear Stress (non beam)

Stress that acts perpendicular to an *axis or length* of a member, or **parallel** to the cross section is called shear stress.

Shear stress cannot be assumed to be uniform, so we refer to *average shearing stress*.

$$f_v = \tau = \frac{P}{A_{net}} \quad \text{Strength condition: } f_v = \frac{P}{A_{net}} < \tau_{allowable} \text{ or } F_{allowed}$$

Bearing Stress

A compressive normal stress acting *between two bodies*.

$$f_p = \frac{P}{A_{bearing}}$$

Torsional Stress

A shear stress caused by torsion (moment around the axis).

$$f_v = \frac{T\rho}{J}$$

Bolt Shear Stress

Single shear - forces cause only one shear “drop” across the bolt. $f = \frac{P}{1A_{bolt}}$

Double shear - forces cause two shear changes across the bolt. $f = \frac{P}{2A_{bolt}}$

Bearing of a bolt on a bolt hole – The bearing surface can be represented by *projecting* the cross section of the bolt hole on a plane (into a rectangle).

$$f_p = \frac{P}{A} = \frac{P}{td}$$

Bending Stress

A normal stress caused by bending; can be compressive or tensile. The stress at the neutral surface or *neutral axis*, which is the plane at the *centroid* of the cross section is zero.

$$f_b = \frac{My}{I} = \frac{M}{S}$$

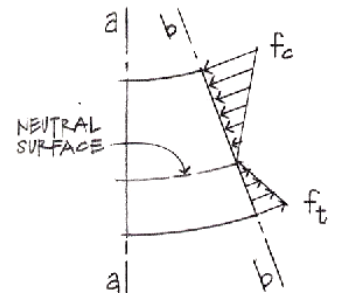

Figure 8.8 Bending stresses on section b-b.

Beam Shear Stress

$f_{v-ave} = 0$ on the beam's surface. Even if Q is a maximum at $y = 0$, we don't know that the thickness is a *minimum* there.

$$f_v = \frac{V}{\Delta A} = \frac{V}{b \cdot \Delta x}$$

$$f_{v-ave} = \frac{VQ}{Ib}$$

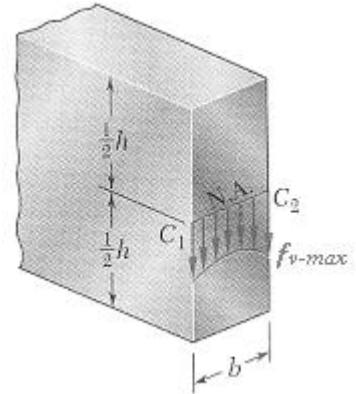
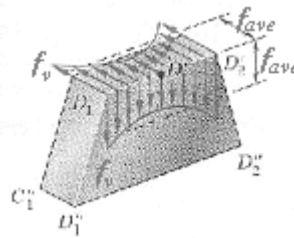

Rectangular Sections

f_{v-max} occurs at the neutral axis: $f_v = \frac{VQ}{Ib} = \frac{3V}{2A}$

Webs of Beams

In steel W or S sections the thickness varies from the flange to the web. We neglect the shear stress in the flanges and consider the shear stress in the web to be constant:

$$f_{v-max} = \frac{3V}{2A} \approx \frac{V}{A_{web}}$$

Connectors in Bending

Typical connections needing to resist shear are plates with nails or rivets or bolts in composite sections or splices. The pitch (spacing) can be determined by the capacity in shear of the connector(s) to the shear flow over the spacing interval, p .

$$\frac{V_{longitudinal}}{p} = \frac{VQ}{I} \quad nF_{connector} \geq \frac{VQ_{connected\ area}}{I} \cdot p$$

where

p = pitch length

n = number of connectors connecting the connected area to the rest of the cross section

F = force capacity in one connector

$Q_{connected\ area} = A_{connected\ area} \times y_{connected\ area}$

$y_{connected\ area}$ = distance from the centroid of the connected area to the neutral axis

Normal Strain

In an axially loaded member, normal strain, ϵ is the change in the length, δ with respect to the original length, L .

$$\epsilon = \frac{\delta}{L}$$

Shearing Strain

In a member loaded with shear forces, shear strain, γ is the change in the sheared side, δ_s with respect to the original height, L . For small angles: $\tan \phi \cong \phi$.

$$\gamma = \frac{\delta_s}{L} = \tan \phi \cong \phi$$

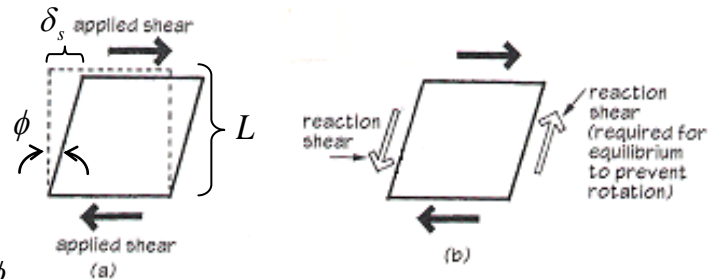

In a member subjected to twisting, the shearing strain is a measure of the angle of twist with respect to the length and distance from the center, ρ :

$$\gamma = \frac{\rho \phi}{L}$$

Stress vs. Strain

Behavior of materials can be measured by recording deformation with respect to the size of the load. For members with constant cross section area, we can plot stress vs. strain.

BRITTLE MATERIALS - ceramics, glass, stone, cast iron; show abrupt fracture at small strains.

DUCTILE MATERIALS – plastics, steel; show a yield point and large strains (considered *plastic*) and “necking” (give warning of failure)

SEMI-BRITTLE MATERIALS – concrete; show no real yield point, small strains, but have some “strain-hardening”.

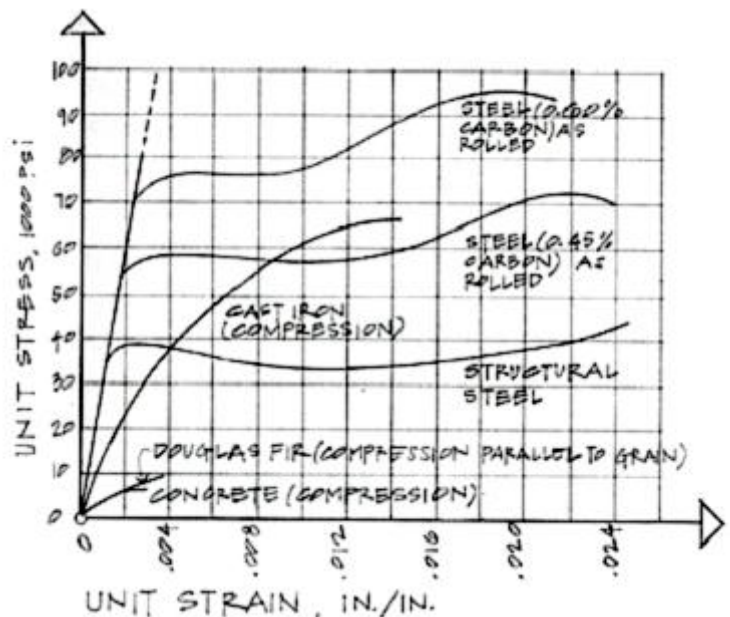

Linear-Elastic Behavior

In the straight portion of the stress-strain diagram, the materials are *elastic*, which means if they are loaded and unloaded no permanent **deformation** occurs.

True Stress & Engineering Stress

True stress takes into account that the area of the cross section changes with loading.

Engineering stress uses the original area of the cross section.

Hooke’s Law – Modulus of Elasticity

In the linear-elastic range, the slope of the stress-strain diagram is *constant*, and has a value of E , called Modulus of Elasticity or Young’s Modulus.

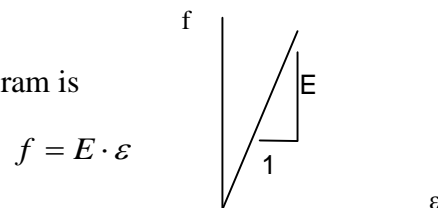

Isotropic Materials – have the **same** E with any direction of loading.

Anisotropic Materials – have **different** E's with the direction of loading.

Orthotropic Materials – have **directionally based** E's

Table D-1 Elastic moduli of selected materials

Material	Modulus of elasticity E		Shear modulus G		Poisson's ratio ν
	10^6 psi	GPa	10^6 psi	GPa	
Aluminum	10	70	3.8	26	0.33
Aluminum alloys	10–12	70–80	3.8–4.4	26–30	0.33
2014-T6	10.6	73	4	28	0.33
6061-T6	10	70	3.8	26	0.33
7075-T6	10.4	72	3.9	27	0.33
Brick (compression)	1.5–3.5	10–24			
Cast iron	12–25	80–170	4.5–10	31–69	0.2–0.3
Gray cast iron	14	97	5.6	39	0.25
Concrete (compression)	2.6–4.4	18–30			0.1–0.2
Copper	17	115	6.2	43	0.35
Copper alloys	14–18	96–120	5.2–6.8	36–47	0.33–0.35
Brass	14–16	96–110	5.2–6	36–41	0.34
80% Cu, 20% Zn	15	100	5.5	38	0.33
Naval brass	15	100	5.5	38	0.33
Bronze	14–17	96–120	5.2–6.3	36–44	0.34
Manganese bronze	15	100	5.6	39	0.35
Glass	7–12	50–80	2.9–5	20–33	0.20–0.27
Magnesium	5.8	40	2.2	15	0.34
Nickel	30	210	11.4	80	0.31
Nylon	0.3–0.4	2–3			0.4
Rubber	0.0001–0.0006	0.001–0.004	0.00004–0.0002	0.0003–0.0014	0.44–0.50
Steel	28–32	190–220	10.8–12.3	75–85	0.28–0.30
Stone (compression)					
Granite	6–10	40–70			0.2–0.3
Marble	7–14	50–100			0.2–0.3
Titanium	16	110	5.8	40	0.33
Titanium alloys	15–18	100–124	5.6–6.8	39–47	0.33
Tungsten	52	360	22	150	0.2
Wood (bending)					
Ash	1.5–1.6	10–11			
Oak	1.6–1.8	11–12			
Southern pine	1.6–2	11–14			
Wrought iron	28	190	10.9	75	0.3

Plastic Behavior & Fatigue

Permanent deformations happen outside the linear-elastic range and are called *plastic* deformations. Fatigue is damage caused by reversal of loading.

- The proportional limit (at the end of the **elastic** range) is the greatest stress valid using Hooke's law.
- The elastic limit is the maximum stress that can be applied before permanent deformation would appear upon unloading.
- The yield point (at the **yield stress**) is where a ductile material continues to elongate without an increase of load. (May not be well defined on the stress-strain plot.)
- The ultimate strength is the largest stress a material will see before rupturing, also called the *tensile strength*.
- The rupture strength is the stress at the point of rupture or failure. It may not coincide with the ultimate strength in ductile materials. In brittle materials, it will be the same as the ultimate strength.
- The fatigue strength is the stress at failure when a member is subjected to reverse cycles of stress (up & down or compression & tension). This can happen at much lower values than the ultimate strength of a material.
- Toughness of a material is how much work (a combination of stress and strain) is used for fracture. It is the area under the stress-strain curve.

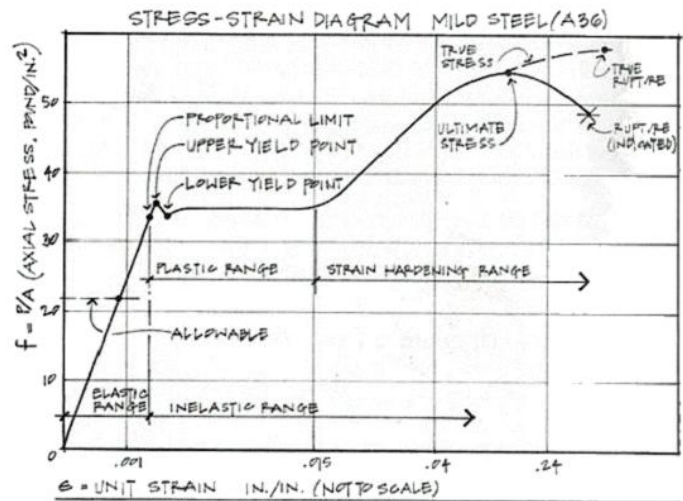

Concrete does not respond well to tension and is tested in compression. The strength at crushing is called the *compression strength*.

Materials that have time dependent elongations when loaded are said to have *creep*. Concrete and wood creep. Concrete also has the property of shrinking over time.

Poisson's Ratio

For an isotropic material that is homogeneous, the properties are the same for the cross section:

$$\epsilon_y = \epsilon_z$$

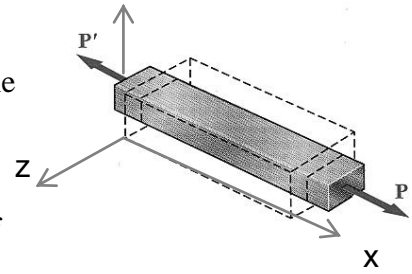

There exists a linear relationship while in the linear-elastic range of the material between *longitudinal strain* and *lateral strain*:

$$\mu = -\frac{\text{lateral strain}}{\text{axial strain}} = -\frac{\epsilon_y}{\epsilon_x} = -\frac{\epsilon_z}{\epsilon_x} \quad \epsilon_y = \epsilon_z = -\frac{\mu f_x}{E}$$

Positive strain results from an increase in length with respect to overall length.

Negative strain results from a decrease in length with respect to overall length.

μ is the Poisson's ratio and has a value between 0 and 1/2, depending on the material

Relation of Stress to Strain

$$f = \frac{P}{A}; \quad \epsilon = \frac{\delta}{L} \quad \text{and} \quad E = \frac{f}{\epsilon} \quad \text{so} \quad E = \frac{P/A}{\delta/L} \quad \text{which rearranges to:} \quad \delta = \frac{PL}{AE}$$

Stress Concentrations

In some sudden changes of cross section, the stress concentration changes (and is why we used *average* normal stress). Examples are sharp notches, or holes or corners.

Plane of Maximum Stress

When both normal stress and shear stress occur in a structural member, the *maximum stresses can occur at some other planes* (angle of θ).

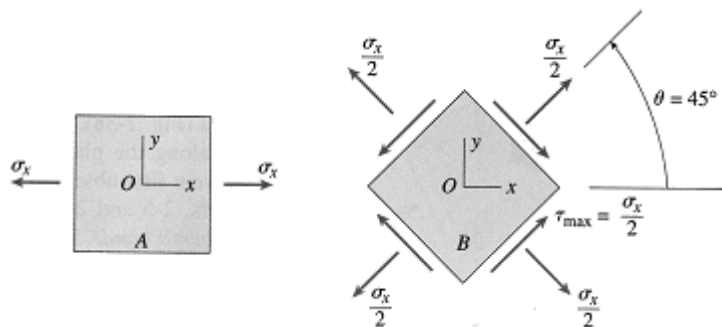

Maximum Normal Stress happens at $\theta = 0^\circ$ AND

Maximum Shearing Stress happens at $\theta = 45^\circ$ with only normal stress in the *x* direction.

Thermal Strains

Physical restraints limit deformations to be the same, or sum to **zero**, or be proportional with respect to the rotation of a rigid body.

We know axial stress relates to axial strain: $\delta = \frac{PL}{AE}$ which relates δ to P

Deformations can be caused by the *material* reacting to a change in energy with temperature. In general (there are some exceptions):

- Solid materials can **contract** with a decrease in temperature.
- Solid materials can **expand** with an increase in temperature.

The change in length per unit temperature change is the *coefficient of thermal expansion*, α . It has units of $\text{1}/^\circ\text{F}$ or $\text{1}/^\circ\text{C}$ and the deformation is related by:

$$\delta_T = \alpha(\Delta T)L$$

Coefficient of Thermal Expansion

Material	Coefficients (α) [in./in./°F]	Coefficients (α) [mm/mm/°C]
Wood	3.0×10^{-6}	5.4×10^{-6}
Glass	4.4×10^{-6}	8.0×10^{-6}
Concrete	5.5×10^{-6}	9.9×10^{-6}
Cast Iron	5.9×10^{-6}	10.6×10^{-6}
Steel	6.5×10^{-6}	11.7×10^{-6}
Wrought Iron	6.7×10^{-6}	12.0×10^{-6}
Copper	9.3×10^{-6}	16.8×10^{-6}
Bronze	10.1×10^{-6}	18.1×10^{-6}
Brass	10.4×10^{-6}	18.8×10^{-6}
Aluminum	12.8×10^{-6}	23.1×10^{-6}

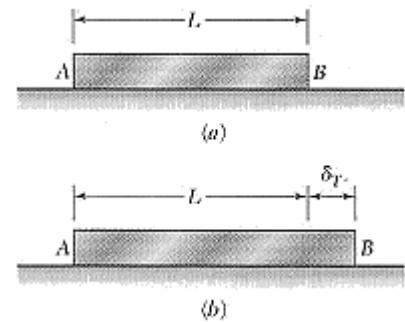

Thermal Strain: $\epsilon_T = \alpha\Delta T$

There is **no stress** associated with the length change with free movement, BUT if there are restraints, thermal deformations or strains *can cause internal forces and stresses*.

How A Restrained Bar Feels with Thermal Strain

1. Bar pushes on supports because the material needs to expand with an increase in temperature.
2. Supports push *back*.
3. Bar is restrained, can't move and the reaction causes internal *stress*.

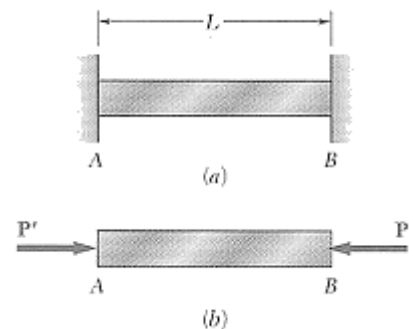

Superposition Method

If we want to solve a statically indeterminate problem that has extra support forces:

- We can remove a support or supports that *makes the problem look statically determinate*
- Replace it with a reaction and treat it like it is an applied force
- Impose geometry restrictions that the support imposes

$$\theta = \text{slope} = \frac{1}{EI} \int M(x) dx$$

Beam Deflections

If the bending moment changes, $M(x)$ across a beam of constant material and cross section then the curvature will change:

The slope of the n.a. of a beam, θ , will be tangent to the radius of curvature, R :

The equation for deflection, y , along a beam is:

$$y = \Delta = \frac{1}{EI} \int \theta dx = \frac{1}{EI} \iint M(x) dx$$

Elastic curve equations can be found in handbooks, textbooks, design manuals, etc...Computer programs can be used as well.

Elastic curve equations can be **superpositioned** ONLY if the stresses are in the elastic range.

Column Buckling

Stability is the ability of the structure to support a specified load without undergoing unacceptable (or sudden) deformations. A column loaded centrally can experience unstable equilibrium, called *buckling*, because of how tall and slender they are. This instability is sudden and not good.

Buckling can occur in sheets (like my “memory metal” cookie sheet), pressure vessels or slender (narrow) beams not braced laterally.

The critical axial load to cause buckling is related to the deflected shape we could get (or determine from bending moment of $P \cdot \Delta$) as a function of the end conditions.

Swiss mathematician Euler determined the relationship between the critical buckling load, the material, section and effective length (as long as the material stays in the elastic range):

$$P_{critical} = \frac{\pi^2 EI_{min}}{(L)^2} \quad \text{or} \quad P_{cr} = \frac{\pi^2 EI}{(L_e)^2} = \frac{\pi^2 EA}{\left(\frac{L_e}{r}\right)^2}$$

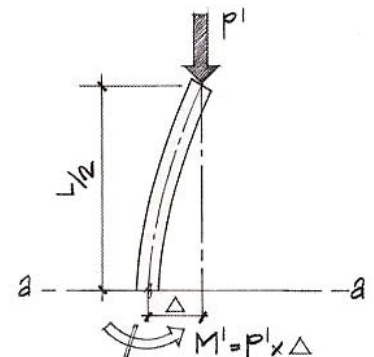

and the critical stress (if less than the normal stress) is:

$$f_{critical} = \frac{P_{critical}}{A} = \frac{\pi^2 E A r^2}{A(L_e)^2} = \frac{\pi^2 E}{\left(\frac{L_e}{r}\right)^2}$$

where $I=Ar^2$ and L_e/r is called the slenderness ratio. The smallest I of the section will govern.

Radius of gyration is a relationship between I and A. It is useful for comparing columns of different shape cross section shape.

$$r_x = \sqrt{\frac{I_x}{A}} \quad r_y = \sqrt{\frac{I_y}{A}}$$

Yield Stress and Buckling Stress

The two design criteria for columns are that they do not buckle and the strength is not exceeded. Depending on slenderness, one will control over the other.

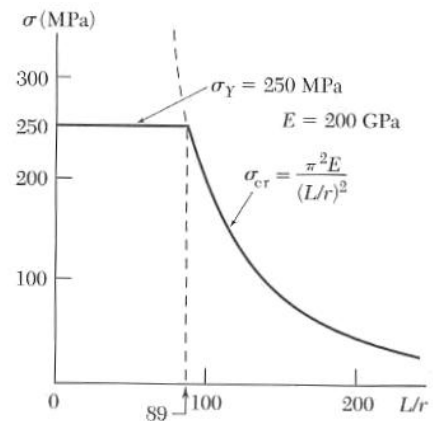

Effective Length and Bracing

Depending on the end support conditions for a column, the effective length can be found from the deflected shape (elastic equations). If a very long column is braced intermittently along its length, the column length that will buckle can be determined. The effective length can be found by multiplying the column length by an effective length factor, K.

$$L_e = K \cdot L$$

Buckled shape of column shown by dashed line	(a)	(b)	(c)	(d)	(e)	(f)
	Theoretical K value	0.5	0.7	1.0	1.0	2.0
Recommended design values when ideal conditions are approximated	0.65	0.80	1.0	1.2	2.10	2.0
End conditions code	Rotation fixed, Translation fixed Rotation free, Translation fixed Rotation fixed, Translation free Rotation free, Translation free					

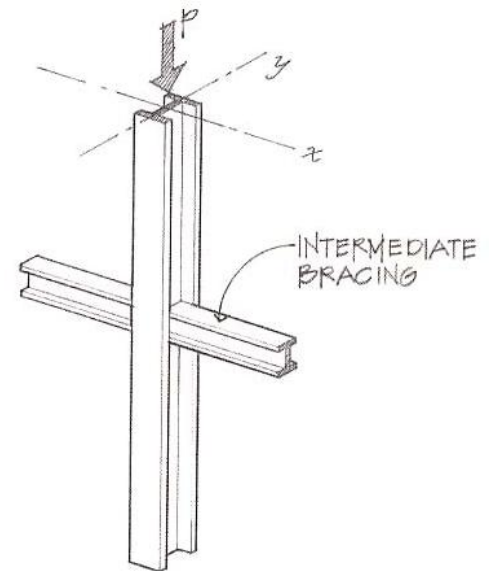

Example 1

Example Problem 6.8 (Figures 6.18 to 6.20)

A pipe storage rack is used for storing pipe in a shop. The support rack beam is fastened to the main floor beam using steel straps $\frac{1}{2}'' \times 2''$ in dimension. Round bolts are used to fasten the strap to the floor beam in single shear. (a) If the weight of the pipes impose a maximum tension load of 10,000 pounds in each strap, determine the tension stress developed in the steel strap. (b) Also, what diameter bolt is necessary to fasten the strap to the floor beam if the allowable shear stress for the bolts equals $F_v = 15,000 \text{ lb./in.}^2$?

Solution:

- a. The tensile stress developed in the steel strap (Figure 6.19) can be determined using the direct stress formula.

$$f_t = \frac{P}{A} = \frac{10,000 \text{ lb.}}{\left(\frac{1}{2}'' \times 2''\right)} = 10,000 \text{ lb./in.}^2$$

In mild steel (A36), the maximum permissible tensile stress (allowable) is equal to

$$F_t \text{ (allowable)} = 22,000 \text{ psi}$$

Therefore, the strap size is adequate to support the tensile load safely.

- b. To determine the size bolt necessary to carry the load safely in single shear, the design form of the equation must be used.

$$f_v = \frac{P}{A'} \quad A = \frac{P}{F_v} = \frac{10,000 \text{ lb.}}{15,000 \text{ lb./in.}^2} = 0.67 \text{ in.}^2$$

$$A = \frac{\pi D^2}{4}; \quad D^2 = \frac{4 \times A}{\pi} = \frac{4 \times 0.67 \text{ in.}^2}{3.14}$$

$$= 0.854 \text{ in.}^2$$

$$D = 0.92 \text{ in.}; \quad \text{Use: } 1'' \phi \text{ bolt.}$$

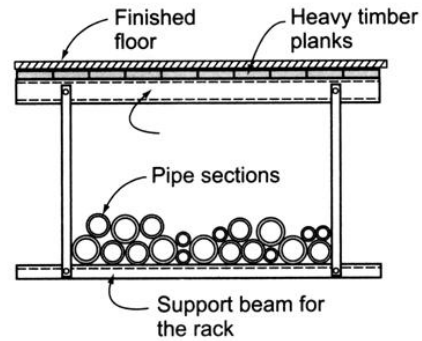

Figure 6.18 Pipe storage rack.

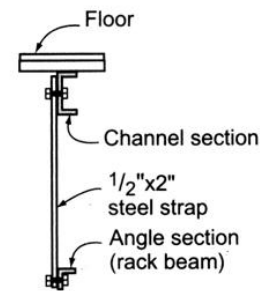

Figure 6.19 Section.

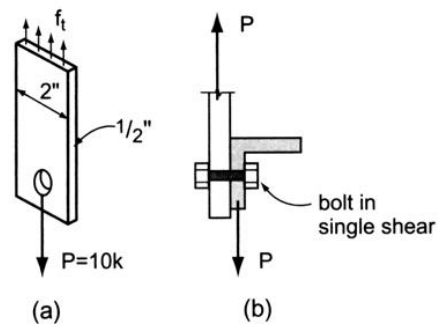
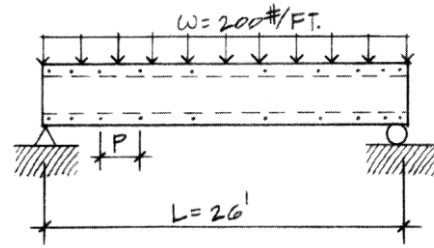

Figure 6.20 Bolt in single shear.

Example 2

8.11 A built-up plywood box beam with 2 × 4 S4S top and bottom flanges is held together by nails. Determine the pitch (spacing) of the nails if the beam supports a uniform load of 200 #/ft. along the 26-foot span. Assume the nails have a shear capacity of 80# each.



Solution:

Construct the shear (V) diagram to obtain the critical shear condition and its location

Note that the condition of shear is critical at the supports, and the shear intensity decreases as you approach the center line of the beam. This would indicate that the nail spacing *P* varies from the support to midspan. Nails are closely spaced at the support, but increasing spacing occurs toward midspan, following the shear diagram.

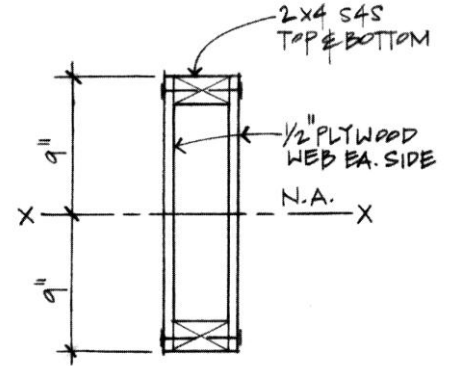

$$f_v = \frac{VQ}{Ib}$$

$$I_x = \frac{(4.5'')(18'')^3}{12} - \frac{(3.5'')(15'')^3}{12} = 1,202.6 \text{ in.}^4$$

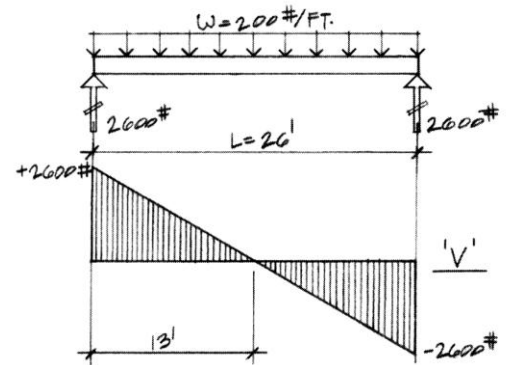
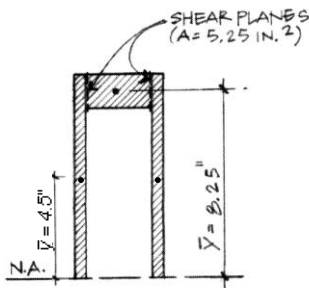

$$f_{v-max} = \frac{\epsilon}{(1,202.6 \text{ in.}^4)(\frac{1}{2}'' + \frac{1}{2}'')} = 180.2 \text{ psi}$$

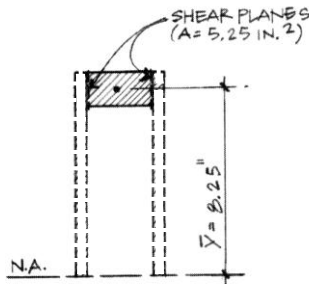

$$Q = A\bar{y} = (5.25 \text{ in.}^2)(8.25'') = 43.3 \text{ in.}^3$$

$$\text{Shear force} = f_v \times A_v$$

where:

$$A_v = \text{shear area}$$

Assume:

F = Capacity of two nails (one each side) at the flange; representing two shear surfaces

$$(n)F \geq f_v \times b \times p = \frac{VQ}{Ib} \times bp$$

$$\therefore (n)F \geq p \times \frac{VQ}{I}; \quad p \leq \frac{(n)FI}{VQ}$$

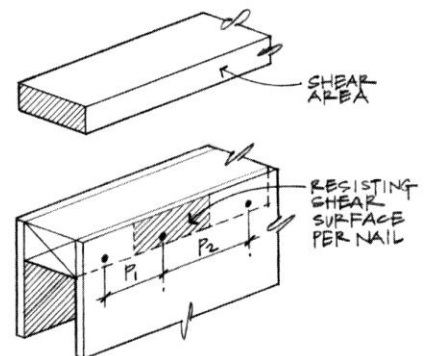

At the maximum shear location (support) where *V* = 2,600#

$$p \leq \frac{(2 \text{ nails} \times 80 \text{ #/nail})(1,202.6 \text{ in.}^4)}{(2,600\#)(43.3 \text{ in.}^3)} = 1.71''$$

Example 3

6.4 THERMAL EFFECTS

Most structural materials expand in volume when subjected to heat and contract when cooled. Whenever a design prevents the change in length of a member subjected to temperature variation, internal stresses develop. Sometimes these *thermal stresses* may be sufficiently high to exceed the elastic limit and cause serious damage. Free, *unrestrained members* experience no stress changes with temperature changes, but dimensional change results. For example, it is common practice to provide expansion joints between sidewalk pavements to allow movement during hot summer days. Prevention of expansion on a hot day would undoubtedly result in severe buckling of the pavement.

The dimensional change due to temperature changes is usually described in terms of the change in a linear dimension. The change in length of a structural member, ΔL , is directly proportional to both the temperature change (ΔT) and the original length of the member L . *Thermal sensitivity*, called the *coefficient of linear expansion* (α), has been determined for all engineering materials (see Table 6.3). Careful measurements have shown that the ratio of strain ϵ to temperature change ΔT is a constant:

$$\alpha = \frac{\text{strain}}{\text{temp. change}} = \frac{\epsilon}{\Delta T} = \frac{\delta/L}{\Delta T}$$

Solving this equation for the deformation:

where:

$$\delta = \alpha L \Delta T$$

where:

- α = coefficient of thermal expansion or contraction
- L = original length of the member (inches or mm)
- ΔT = change in temperature ($^{\circ}\text{F}$ or $^{\circ}\text{C}$)
- δ = total change in length (in. or mm)

Of perhaps even greater importance in engineering design are the stresses developed by restraining the free expansion and contraction of members subjected to temperature variations. To calculate these temperature stresses, it is useful to determine first the free expansion or contraction of the member involved and, second, the force and unit stress developed in forcing the member to attain its original length. The problem from this point on is exactly the same as those solved in the earlier portions of this chapter dealing with axial stresses, strains, and deformations. The amount of stress developed by restoring a bar to its original length L is:

$$f = \epsilon E = \frac{\delta}{L} E = \frac{\alpha L \Delta T E}{L} = \alpha \Delta T E$$

$$\therefore f = \alpha \Delta T E$$

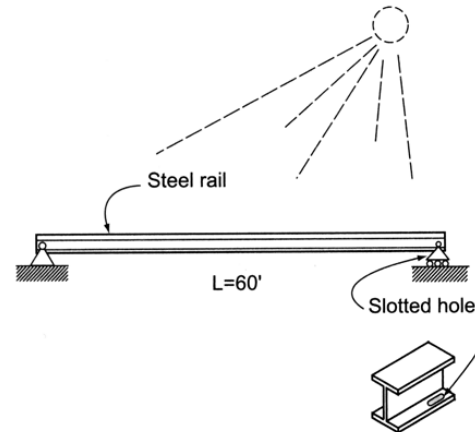

Figure 6.57 Steel rail subjected to thermal change.

Example Problem 6.21 (Figure 6.57)

A 60' length of steel rail is laid on a day when the temperature is 40°F . In order to prevent the rail from developing any internal stresses due to a thermal increase of 60°F , what is the amount of deformation that needs to be accommodated with respect to the slotted connection at the rail end(s)? $E_{st} = 29 \times 10^3$ ksi.

Solution:

Steel has a coefficient of expansion $\alpha = 6.5 \times 10^{-6}/^{\circ}\text{F}$ (see Table 6.3).

Using the deformation equation due to thermal change:

$$\begin{aligned} \delta &= \alpha L \Delta T = (6.5 \times 10^{-6}/^{\circ}\text{F})(60' \times 12 \text{ in./ft.})(60^{\circ}\text{F}) \\ &= 0.28'' \end{aligned}$$

This amount of deformation (0.28") for a 60'-long rail section may not seem large but if there are no provisions made to allow movement during thermal changes, large internal stress may result. If the rail section in this example has a cross-sectional area of $A = 10.5 \text{ in.}^2$, determine the amount of internal compressive stress that can result if the rail is restrained from moving.

$$\begin{aligned} f &= \alpha \Delta T E = (6.5 \times 10^{-6}/^{\circ}\text{F})(60^{\circ}\text{F})(29 \times 10^3 \text{ k/in.}^2) \\ &= 11.31 \text{ ksi} \end{aligned}$$

(a very large internal stress which can potentially cause the rail to buckle)

Example 4

A short concrete column measuring 12 in. square is reinforced with four #8 bars ($A_s = 4 \times 0.79 \text{ in.}^2 = 3.14 \text{ in.}^2$) and supports an axial load of 250k. Steel bearing plates are used top and bottom to ensure equal deformations of steel and concrete. Calculate the stress developed in each material if:

$$E_c = 3 \times 10^6 \text{ psi and}$$

$$E_s = 29 \times 10^6 \text{ psi}$$

Solution:

From equilibrium:

$$[\Sigma F_y = 0] - 250 \text{ k} + f_s A_s + f_c A_c = 0$$

$$A_s = 3.14 \text{ in.}^2$$

$$A_c = (12'' \times 12'') - 3.14 \text{ in.}^2 \cong 141 \text{ in.}^2$$

$$3.14 f_s + 141 f_c = 250 \text{ k}$$

From the deformation relationship:

$$\delta_s = \delta_c; L_s = L_c$$

$$\therefore \frac{\delta_s}{L} = \frac{\delta_c}{L}$$

and

$$\epsilon_s = \epsilon_c$$

Since

$$E = \frac{f}{\epsilon}$$

and

$$\frac{f_s}{E_s} = \frac{f_c}{E_c}$$

$$f_s = f_c \frac{E_s}{E_c} = \frac{29 \times 10^3 (f_c)}{3 \times 10^3} = 9.67 f_c$$

Substituting into the equilibrium equation:

$$3.14 (9.67 f_c) + 141 f_c = 250$$

$$30.4 f_c + 141 f_c = 250$$

$$171.4 f_c = 250$$

$$f_c = 1.46 \text{ ksi}$$

$$\therefore f_s = 9.67 (1.46) \text{ ksi}$$

$$f_s = 14.1 \text{ ksi}$$

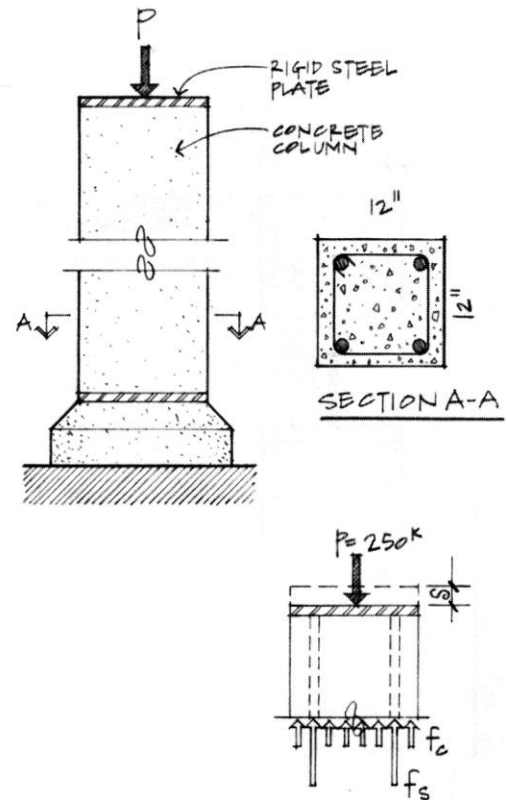

Example 5

Determine the deflection in the steel beam if it is a W15 x 88. $E = 30 \times 10^3$ ksi.

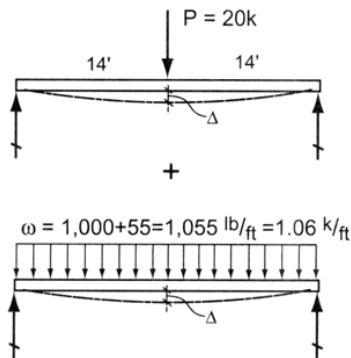

Deflection Check:

$$\Delta_{\text{actual}} = \frac{PL^3}{48EI} + \frac{5\omega L^4}{384EI}$$

$$\Delta_{\text{actual}} = \frac{(20 \text{ k})(28')^3(1728)}{48(30 \times 10^3)(890)} + \frac{5(1.06 \text{ k/ft.})(28')^4(1728)}{384(30 \times 10^3)(890)}$$

$$\Delta_{\text{actual}} = 0.59'' + 0.55'' = 1.14''$$

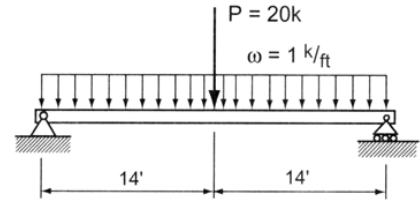

Example 6

Example Problem 10.6 (Figures 10.28 to 10.30)

A W8x40 steel column supports trusses framed into its web, which serve to fix the weak axis and light beams that attach to the flange, simulating a pin connection about the strong axis. If the base connection is assumed as a pin, determine the critical buckling load the column is capable of supporting.

Solution:

W8x40; ($A = 11.7 \text{ in.}^2$, $r_x = 3.53''$, $I_x = 146 \text{ in.}^4$,
 $r_y = 2.04''$, $I_y = 49.1 \text{ in.}^4$)

The first step is to determine the critical axis for buckling (i.e., which one has the larger KL/r).

Weak Axis:

$$L_e = KL = 0.7(34') = 23.8'$$

$$\frac{KL}{r_y} = \frac{23.8' \times 12 \text{ in./ft.}}{2.04''} = 140$$

Strong Axis:

$$L_e = L; K = 1.0; KL = 37'$$

$$\frac{KL}{r_x} = \frac{(37' \times 12 \text{ in./ft.})}{3.53''} = 125.8$$

The weak axis for this column is critical since

$$\frac{KL}{r_y} > \frac{KL}{r_x}$$

$$P_{\text{cr.}} = \frac{\pi^2 EI_y}{(KL)^2} = \frac{(3.14)^2 (29 \times 10^3 \text{ ksi})(49.1 \text{ in.}^4)}{(23.8' \times 12 \text{ in./ft.})^2}$$

$$= 172.1 \text{ k}$$

$$f_{\text{critical}} = \frac{P_{\text{crit.}}}{A} = \frac{172.1 \text{ k}}{11.7 \text{ in.}^2} = 14.7 \text{ ksi}$$

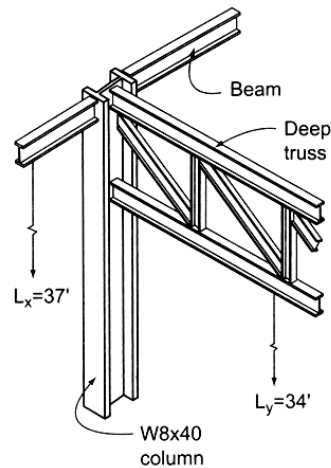

Figure 10.28 Truss/column framing.

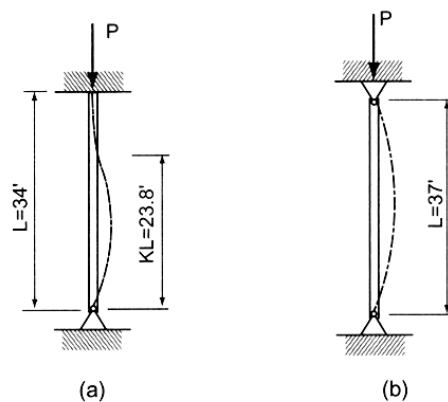

Figure 10.30 (a) Weak axis. (b) Strong axis.