

Statics Primer

Notation:

<p>a = name for acceleration</p> <p>A = area (net = with holes, bearing = in contact, etc...)</p> <p>(C) = shorthand for <i>compression</i></p> <p>d = perpendicular distance to a force from a point</p> <p>d_x = difference in the x direction between an area centroid (\bar{x}) and the centroid of the composite shape (\hat{x})</p> <p>d_y = difference in the y direction between an area centroid (\bar{y}) and the centroid of the composite shape (\hat{y})</p> <p>F = name for force vectors, as is A, B, C, T and P</p> <p>F_x = force component in the x direction</p> <p>F_y = force component in the y direction</p> <p>g = acceleration due to gravity</p> <p>h = name for height</p> <p>\bar{I} = moment of inertia about the centroid</p> <p>I_x = moment of inertia with respect to an x-axis</p> <p>I_y = moment of inertia with respect to a y-axis</p> <p>L = beam span length</p> <p>m = name for mass</p> <p>M = moment due to a force or internal bending moment</p> <p>N = name for normal force to a surface</p> <p>p = pressure</p> <p>Q_x = first moment area about an x axis (using y distances)</p>	<p>Q_y = first moment area about an y axis (using x distances)</p> <p>R = name for resultant vectors</p> <p>R_x = resultant component in the x direction</p> <p>R_y = resultant component in the y direction</p> <p>$tail$ = start of a vector (without arrowhead)</p> <p>tip = direction end of a vector (with arrowhead)</p> <p>(T) = shorthand for <i>tension</i></p> <p>V = internal shear force</p> <p>w = name for distributed load</p> <p>$w_{s(elf) w(t)}$ = name for distributed load from self weight of member</p> <p>W = name for force due to weight</p> <p>x = x axis direction or algebra variable</p> <p>\bar{x} = the distance in the x direction from a reference axis to the centroid of a shape</p> <p>y = y axis direction or algebra variable</p> <p>\bar{y} = the distance in the y direction from a reference axis to the centroid of a shape</p> <p>α = angle, in math</p> <p>β = angle, in math</p> <p>γ = angle, in math</p> <p>μ = coefficient of static friction</p> <p>θ = angle, in a trig equation, ex. $\sin\theta$, that is measured between the x axis and <i>tail</i> of a vector</p> <p>Σ = summation symbol</p>
---	---

Newton's Laws of Motion

Newton's laws govern the behavior of physical bodies, whether at rest or moving:

- **First Law.** *A particle originally at rest, or moving in a straight line with constant velocity, will remain in this state provided the particle is not subjected to an unbalanced force.*
- **Second Law.** *A particle of mass m acted upon by an unbalanced force experiences an acceleration that has the same direction as the force and a magnitude that is directly proportional to the force. This is expressed mathematically as: $\bar{F} = m\bar{a}$,*

where \mathbf{F} and \mathbf{a} are vector (directional) quantities, and m is a scalar quantity.

- **Third Law.** *The mutual forces of action and reaction between two particles are equal, opposite, and collinear.*

Units

Units are necessary to define quantities. Standards exist to relate quantities in a convention system, such as the International System of Units (SI) or the U.S. Customary system.

Units	Mass	Length	Time	Force
SI	kg	m	s	$N = \frac{kg \cdot m}{s^2}$
Absolute English	lb	ft	s	$Poundal = \frac{lb \cdot ft}{s^2}$
Technical English	$slug = \frac{lb_f \cdot s^2}{ft}$	ft	s	lb_{force}
Engineering English	lb	ft	s	lb_{force}
	$lb_{force} = lb_{(mass)} \times 32.17 \frac{ft}{s^2}$			
gravitational constant	$g_c = 32.17 \frac{ft}{s^2}$	(English)		$F=mg$
	$g_c = 9.81 \frac{m}{s^2}$	(SI)		
conversions (pg. vii)	$1 in = 25.4 mm$			
	$1 lb = 4.448 N$			

Conversions

Conversion of a quantity from a category within a unit system to a more useful category or to another unit system is very common. Tables of conversion can be found in most physics, statics and design texts.

Numerical Accuracy

- Depends on
- 1) accuracy of data you are given
 - 2) accuracy of the calculations performed

The solution CANNOT be more accurate than the less accurate of #1 and #2 above!

DEFINITIONS: *precision* the number of significant digits
 accuracy the possible error

Relative error measures the degree of accuracy: $\frac{\text{relative error}}{\text{measurement}} \times 100 = \text{degree of accuracy (\%)}$

For engineering problems, accuracy *rarely* is less than 0.2%.

Math for Structures

1. Parallel lines never intersect.
2. Two lines are *perpendicular* (or *normal*) when they intersect at a right angle = 90° .
3. *Intersecting* (or *concurrent*) lines cross or meet at a point.
4. If two lines cross, the opposite angles are identical:
5. If a line crosses two parallel lines, the intersection angles with the same orientation are identical:
6. If the sides of two angles are parallel and intersect in the same fashion, the angles are identical.
7. If the sides of two angles are parallel, but intersect in the opposite fashion, the angles are *supplementary*: $\alpha + \beta = 180^\circ$.
8. If the sides of two angles are perpendicular and intersect in the same fashion, the angles are identical.
9. If the sides of two angles are perpendicular, but intersect in the opposite fashion, the angles are *supplementary*: $\alpha + \beta = 180^\circ$.
10. If the side of two angles bisects a right angle, the angles are *complimentary*:
 $\alpha + \gamma = 90^\circ$.
11. If a right angle bisects a straight line, the remaining angles are *complimentary*: $\alpha + \gamma = 90^\circ$.
12. The sum of the interior angles of a triangle = 180° .
13. For a right triangle, that has one angle of 90° , the sum of the other angles = 90° .
14. For a right triangle, the sum of the squares of the sides equals the square of the hypotenuse:
$$AB^2 + AC^2 = CB^2$$
15. Similar triangles have identical angles in the same orientation. Their sides are related by:

Case 1:

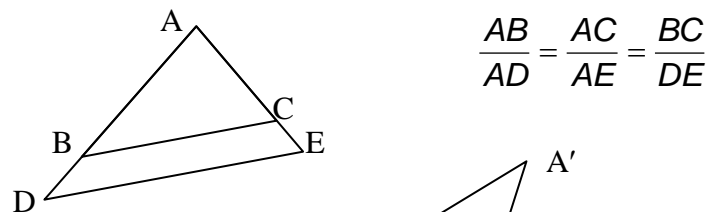

Case 2:

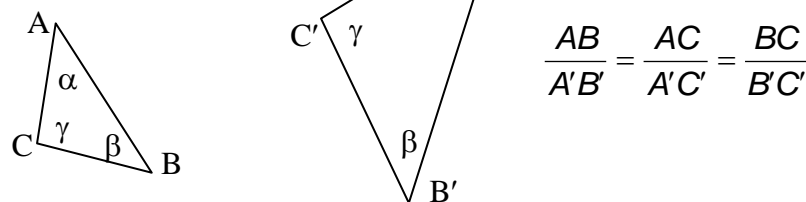

16. For right triangles:

$$\sin = \frac{\text{oppositeside}}{\text{hypotenuse}} = \sin \alpha = \frac{AB}{CB}$$

$$\cos = \frac{\text{adjacentside}}{\text{hypotenuse}} = \cos \alpha = \frac{AC}{CB}$$

$$\tan = \frac{\text{oppositeside}}{\text{adjacent side}} = \tan \alpha = \frac{AB}{AC}$$

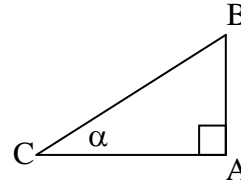

(SOHCAHTOA)

17. If an angle is greater than 180° and less than 360° , \sin will be less than 0.

If an angle is greater than 90° and less than 270° , \cos will be less than 0.

If an angle is greater than 90° and less than 180° , \tan will be less than 0.

If an angle is greater than 270° and less than 360° , \tan will be less than 0.

18. LAW of SINES (any triangle)

$$\frac{\sin \alpha}{A} = \frac{\sin \beta}{B} = \frac{\sin \gamma}{C}$$

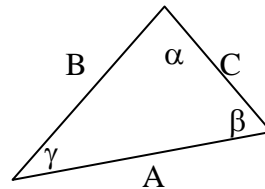

19. LAW of COSINES (any triangle)

$$A^2 = B^2 + C^2 - 2BC \cos \alpha$$

20. Surfaces or areas have dimensions of width and length and units of length *squared* (ex. in² or inches x inches).

21. Solids or volumes have dimension of width, length and height or thickness and units of length *cubed* (ex. m³ or m x m x m)

22. Force is defined as mass times acceleration. So a weight due to a mass is accelerated upon by gravity: $F = m \cdot g$ $g = 9.81 \frac{m}{sec^2} = 32.17 \frac{ft}{sec^2}$

23. Weight can be determined by volume if the unit weight or *density* is known: $W = V \cdot \gamma$ where V is in units of length³ and γ is in units of force/unit volume

24. Algebra: If $a \cdot b = c \cdot d$ then it can be rewritten:

$$a \cdot b + k = c \cdot d + k \quad \text{add a constant}$$

$$c \cdot d = a \cdot b \quad \text{switch sides}$$

$$a = \frac{c \cdot d}{b} \quad \text{divide both sides by } b$$

$$\frac{a}{c} = \frac{d}{b} \quad \text{divide both sides by } b \cdot c$$

25. Cartesian Coordinate System

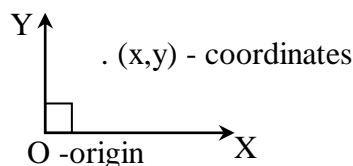

26. Solving equations with one unknown:

1st order polynomial: $2x - 1 = 0 \dots$ $2x = 1 \dots$ $x = \frac{1}{2}$
 $ax + b = 0 \dots$ $x = \frac{-b}{a}$

2nd order polynomial $ax^2 + bx + c = 0 \dots$ $x = \frac{-b \pm \sqrt{b^2 - 4ac}}{2a}$ two answers
 (radical *cannot* be negative)
 $x^2 - 1 = 0 \dots$ $x = \frac{-0 \pm \sqrt{0^2 - 4(-1)}}{2 \cdot 1} \dots$ $x = \pm 1$
 ($a = 1, b = 0, c = -1$)

27. Solving 2 linear equations simultaneously:

One equation consisting only of variables can be rearranged and then substituted into the second equation:

ex: $5x - 3y = 0$ add 3y to both sides to rearrange $5x = 3y$
 $4x - y = 2$ divide both sides by 5 $x = \frac{3}{5}y$
 substitute x into the other equation $4(\frac{3}{5}y) - y = 2$
 add like terms $\frac{7}{5}y = 2$
 simplify $y = \frac{10}{7} = 1.43$

Equations can be added and factored to eliminate one variable:

ex: $2x + 3y = 8$ $2x + 3y = 8$
 $4x - y = 2$ multiply both sides by 3 $12x - 3y = 6$
 and add $14x + 0 = 14$
 simplify $x = 1$
 put $x=1$ in an equation for y $2 \cdot 1 + 3y = 8$
 simplify $3y = 6$
 $y = 2$

28. Derivatives of polynomials

$$y = \text{constant} \quad \frac{dy}{dx} = 0$$

$$y = x \quad \frac{dy}{dx} = 1$$

$$y = ax \quad \frac{dy}{dx} = a$$

$$y = x^2 \quad \frac{dy}{dx} = 2x$$

$$y = x^3 \quad \frac{dy}{dx} = 3x^2$$

29. The minimum and maximum of a function can be found by setting the derivative = 0 and solving for the unknown variable.

30. Calculators (and software) process equations by an “order of operations”, which typically means they process functions like exponentials and square roots before simpler functions such as + or -. BE SURE to specify with parenthesis what order you want, or you’ll get the wrong answers. It is also important to have degrees set in your calculator for trig functions.

For instance, Excel uses – for sign (like -1) first, then will process exponents and square roots, times and divide, followed by plus and minus. If you type 4x10^2 and really mean (4x10)^2 you will get an answer of 400 instead of 1600.

General Procedure for Analysis

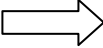
1. Inputs
Outputs
“Critical Path”  $\left. \begin{array}{l} \text{GIVEN:} \\ \text{FIND:} \\ \text{SOLUTION} \end{array} \right\} \text{ on graph paper}$

2. Draw simple diagram of body/bodies & forces acting on it/them.
3. Choose a reference system for the forces.
4. Identify key geometry and constraints.
5. Write the basic equations for force components.
6. Count the equations & unknowns.
7. SOLVE
8. “Feel” the validity of the answer. (Use common sense. Check units...)

Example: Two forces, A & B, act on a particle. What is the resultant?

1. **GIVEN:** Two forces on a particle and a diagram with size and orientation

FIND: The “resultant” of the two forces

SOLUTION:

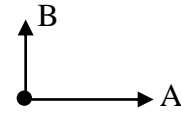

2. Draw what you know (the diagram, any other numbers in the problem statement that could be put on the drawing....)
3. Choose a reference system. What would be the easiest? Cartesian, radian?
4. Key geometry: the location of the particle as the origin of all the forces
Key constraints: the particle is “free” in space
5. Write equations: $size\ of\ A^2 + size\ of\ B^2 = size\ of\ resultant$

$$\sin\alpha = \frac{size\ of\ B}{size\ of\ A + B}$$

6. Count: Unknowns: 2, magnitude and direction \leq Equations: 2 \therefore can solve
7. Solve: graphically or with equations
8. “Feel”: Is the result bigger than A and bigger than B? Is it in the right direction? (like A & B)

Forces

Forces are vectors, which means they have a direction, size and point or line of application. External forces can be moved along the line of action by the *law of transmissibility*. Internal forces are within a material or at a connection between elements.

Force systems can be classified as *concurrent, collinear, coplanar, coplanar-parallel, or space*.

Because they are vector quantities, they cannot be simply added. They must be *graphically* added or *analytically* added by resolving forces into *components* using trigonometry and summed.

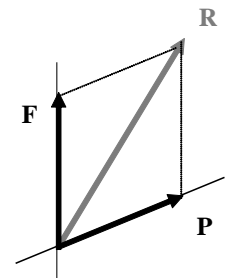

θ is: *between x & F*

$$F_x = F \cdot \cos\theta$$

$$F_y = F \cdot \sin\theta$$

$$F = \sqrt{F_x^2 + F_y^2}$$

$$\tan\theta = \frac{F_y}{F_x}$$

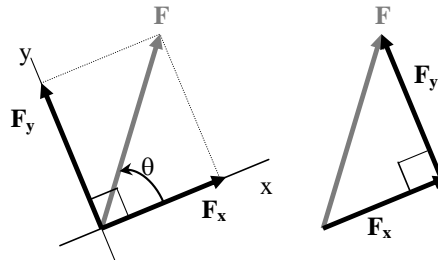

$$R_x = \sum F_x, \quad R_y = \sum F_y, \quad \text{and} \quad R = \sqrt{R_x^2 + R_y^2}$$

$$\tan\theta = \frac{R_y}{R_x}$$

Types of Forces

Forces can be classified as *concentrated* at a point or *distributed* over a length or area. *Uniformly distributed* loads are quite common and have units of lb/ft or N/m. The total load is commonly wanted from the distribution, and can be determined based on an “area” calculation with the load value as the “height”.

Equivalent force systems are the reorganization of the loads in a system so there is a equivalent force put at the same location that would cause the same translation **and** rotation (see Moments).

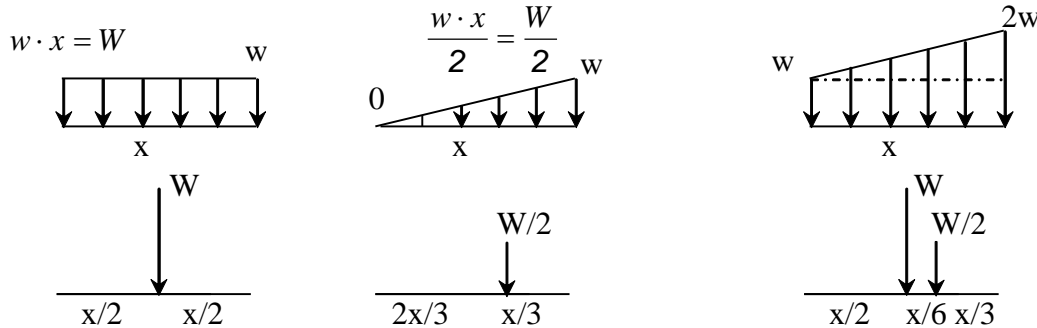

To determine a distributed load due to hydrostatic pressure, the height of the water, h , is multiplied by the material density, γ (62.4 lb/ft³): $p = h\gamma$.

To determine a weight of a beam member per length, the cross section area, A , is multiplied by the material density, γ (ex. concrete = 150 lb/ft³): $w_{s.w.} = A\gamma$. (Care must be taken with units.)

Friction

Friction is a resulting force from the contact of two materials and a normal force. It can be *static* or *kinematic*. Static friction is defined as the product of the normal force, N , with the coefficient of static friction, μ , which is a constant dependant upon the materials in contact: $F = \mu N$

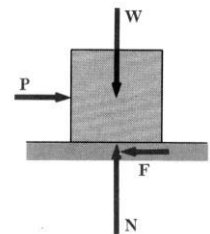

Moments

Moments are the tendency of forces to cause rotation and are *vector* quantities with rotational direction. Most physics texts define positive rotation as *counter clockwise*. With the sign convention, moments can be added.

Moments are defined as the product of the force magnitude, F , with the perpendicular distance from the point of interest to the line of action of the force, d_{\perp} : $M = F \cdot d_{\perp}$

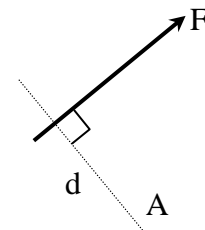

Moment *couples* can be identified with forces of equal size in opposite direction that are *parallel*. The equations is $M = F \cdot d_{\perp}$ where F is the size of *one* of the forces.

Support Conditions

Reaction forces and moments occur at supports for structural elements. The force component directions and moments are determined by the motion that is resisted, for example no rotation will mean a reaction moment. Supports are commonly modeled as these general types, with the drawing symbols of triangles, circles and ground:

Structural Analysis, 4th ed., R.C. Hibbeler

Table 2-1 Supports for Coplanar Structures

Type of Connection	Idealized Symbol	Reaction	Number of Unknowns
(1) light cable weightless link			One unknown. The reaction is a force that acts in the direction of the cable or link.
(2) rollers rocker			One unknown. The reaction is a force that acts perpendicular to the surface at the point of contact.
(3) smooth contacting surface			One unknown. The reaction is a force that acts perpendicular to the surface at the point of contact.
(4) smooth pin-connected collar			One unknown. The reaction is a force that acts perpendicular to the surface at the point of contact.
(5) smooth pin or hinge			Two unknowns. The reactions are two force components.
(6) slider fixed-connected collar			Two unknowns. The reactions are a force and a moment.
(7) fixed support			Three unknowns. The reactions are the moment and the two force components.

Equilibrium

Equilibrium is the state when all the external forces acting on a rigid body form a system of forces equivalent to zero. There will be no rotation or translation. The forces are referred to as balanced.

$$R_x = \sum F_x = 0 \quad R_y = \sum F_y = 0 \quad \text{AND} \quad \sum M = 0$$

Equilibrium for a point already satisfies the sum of moments equal to zero because a force acting through a point will have zero moment from a zero perpendicular distance. This is a very useful concept to apply when summing moments for a rigid body. If the point summed about has unknown forces acting through it, that force variable will not appear in the equilibrium equation as an unknown quantity, allowing for much easier algebra.

Free Body Diagrams

1. Determine the free body of interest. (What body is in equilibrium?)
2. Detach the body from the ground and all other bodies (*“free” it*).
3. Indicate all external forces which include:
 - action on the free body by the **supports & connections**
 - action on the free body by other bodies
 - the weigh effect (=force) of the free body itself (force due to gravity)
4. All forces should be clearly marked with magnitudes and direction. The sense of forces should be those acting *on the body* not by the body.
5. Dimensions/angles should be included for moment computations and force computations.
6. Indicate the unknown angles, distances, forces or moments, such as those reactions or constraining forces where the body is supported or connected.
- The line of action of any unknown should be indicated on the FBD. The sense of direction is determined by the type of support. (Cables are in tension, etc...) *If the sense isn't obvious, assume a sense.* When the reaction value comes out positive, the assumption was correct. When the reaction value comes out negative, the direction is *opposite* the assumed direction. ***DON'T CHANGE THE ARROWS ON YOUR FBD OR SIGNS IN YOUR EQUATIONS.***

With the 3 equations of equilibrium, there can be no more than 3 unknowns for statics. If there are, and the structure is stable, it means that it is *statically indeterminate* and other methods must be used to solve the unknowns. When it is not stable, it is *improperly constrained* and may still look like it has 3 unknowns. It will prove to be unsolvable.

Conditions for Equilibrium of a Rigid Body

1. **Two-force body:** Equilibrium of a body subjected to two forces on two points requires that those forces be **equal** and **opposite** and act in the same line of action.

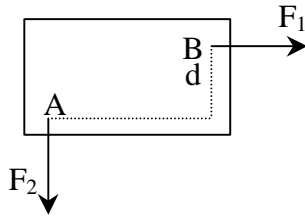
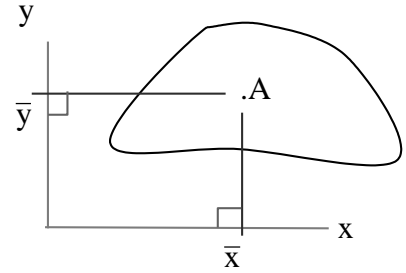

(A)

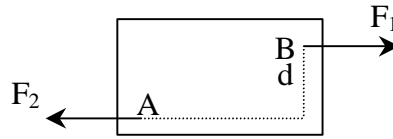

(B)

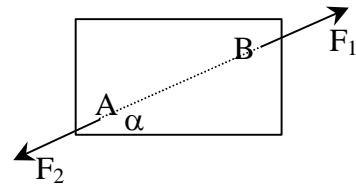

(C)

2. **Three-force body:** Equilibrium of a body subjected to three forces on three points requires that the line of action of the forces be concurrent (intersect) or parallel AND that the resultant equal zero.

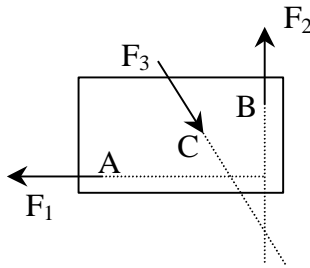

(A) -no

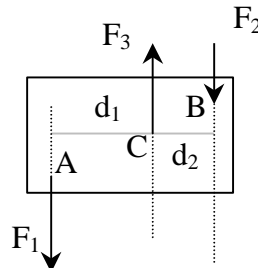

(B)

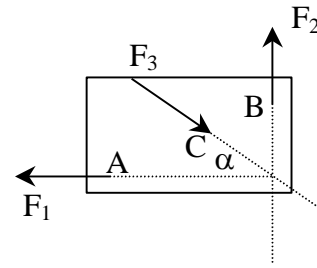

(C)

Geometric Properties

Area is an important quantity to be calculated in order to know material quantities and to find geometric properties for beam and column cross sections. Charts are available for common mathematical relationships.

Centroid For a uniform material, the geometric center of the area is the *centroid* or center of gravity. It can be determined with calculus.

$$\bar{x} = \frac{\sum(x\Delta A)}{A} \qquad \bar{y} = \frac{\sum(y\Delta A)}{A}$$

First Moment Area The product of an area with respect to a distance about an axis is called the first moment area, Q . The quantity is useful for shear stress calculations and to determine the moment of inertia.

$$Q_x = \int y dA = \bar{y}A \qquad Q_y = \int x dA = \bar{x}A$$

Geometric Properties of Areas

Rectangle		$\bar{I}_{x'} = \frac{1}{12}bh^3$ $\bar{I}_{y'} = \frac{1}{12}b^3h$ $I_x = \frac{1}{3}bh^3$ $I_y = \frac{1}{3}b^3h$ $J_C = \frac{1}{12}bh(b^2 + h^2)$	<p>Area = bh</p> <p>$\bar{x} = b/2$</p> <p>$\bar{y} = h/2$</p>
Triangle		$\bar{I}_{x'} = \frac{1}{36}bh^3$ $I_x = \frac{1}{12}bh^3$ $\bar{I}_{y'} = \frac{1}{36}b^3h$	<p>Area = $bh/2$</p> <p>$\bar{x} = b/3$</p> <p>$\bar{y} = h/3$</p>
Circle		$\bar{I}_x = \bar{I}_y = \frac{1}{4}\pi r^4$ $J_O = \frac{1}{2}\pi r^4$	<p>Area = $\pi r^2 = \pi d^2/4$</p> <p>$\bar{x} = 0$</p> <p>$\bar{y} = 0$</p>
Semicircle		$\bar{I}_x = 0.1098r^4$ $\bar{I}_y = \pi r^4/8$	<p>Area = $\pi r^2/2 = \pi d^2/8$</p> <p>$\bar{x} = 0$</p> <p>$\bar{y} = 4r/3\pi$</p>
Quarter circle		$\bar{I}_x = 0.0549r^4$ $\bar{I}_y = 0.0549r^4$	<p>Area = $\pi r^2/4 = \pi d^2/16$</p> <p>$\bar{x} = 4r/3\pi$</p> <p>$\bar{y} = 4r/3\pi$</p>
Ellipse		$\bar{I}_x = \frac{1}{4}\pi ab^3$ $\bar{I}_y = \frac{1}{4}\pi a^3b$ $J_O = \frac{1}{4}\pi ab(a^2 + b^2)$	<p>Area = πab</p> <p>$\bar{x} = 0$</p> <p>$\bar{y} = 0$</p>
Semiparabolic area		$\bar{I}_x = 16ah^3/175$	<p>Area = $4ah/3$</p> <p>$\bar{x} = 0$</p> <p>$\bar{y} = 3h/5$</p>
Parabolic area		$\bar{I}_y = 4a^3h/15$	
Parabolic spandrel		$\bar{I}_x = 37ah^3/2100$ $\bar{I}_y = a^3h/80$	<p>Area = $ah/3$</p> <p>$\bar{x} = 3a/4$</p> <p>$\bar{y} = 3h/10$</p>

Moment of Inertia The moment of inertia is the second area moment of an area, and is found using calculus. For a composite shape, the moment of inertia can be found using the *parallel axis theorem*:

$$I_x = \bar{I}_x + Ad_y^2 \quad I_y = \bar{I}_y + Ad_x^2$$

The theorem states that the sum of the centroid of each composite shape about an axis (subscript axes) can be added but must be added to the second moment area of the shape by the distance between parallel axes (opposite axes direction).

Internal Forces

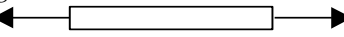
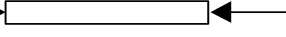
If a body is in equilibrium, it holds that any *section* of that body is in equilibrium. *Two force-bodies* will have internal forces that are *in line* with the body (end points), while *three-force bodies* will see an internal force that will not be axial, in addition to an internal moment called a *bending moment*. An axial force that is pulling the body from both ends is referred to as a *tensile force*,  and a force pushing on the body at both ends is referred to as a *compressive force* .

Cable Analysis

Cables can only see tensile forces. If cables are straight, they are two-force bodies and the geometry of the cable determines the direction of the force.

If cables drape (*are funicular*) by having distributed or gravity loads, the internal vertical force component changes, while the internal horizontal force component does not.

Truss Analysis

Truss members are assembled such that the pins connecting them are the only location of forces (internal and external). This loading assumption relies on there being no bending in the members, and all truss members are then *two-force bodies*.

Equilibrium of the joints will only need to satisfy the x force components summing to 0 and the y force components summing to zero. *The member forces will have direction in the geometry of the member*. Assuming the unknown forces in tension is represented by drawing arrows “away” from the joint. When compression forces are known, they must be drawn “in” to the point.

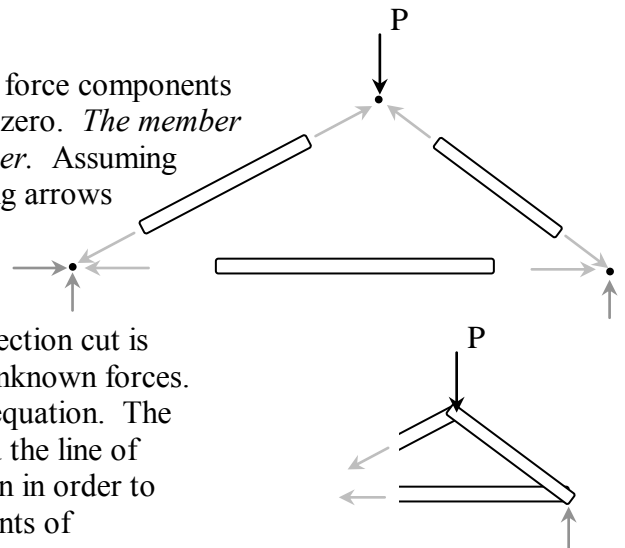

Equilibrium of the section will only be possible if the section cut is through three or less members exposing three or less unknown forces. This method relies on the sum of moment equilibrium equation. The member forces are in the direction of the members, and the line of action of those forces runs through the member location in order to find the perpendicular distance. It is helpful to find points of intersection of unknown forces to sum moments.

Pinned Frame. Arch and Compound Beam Analysis

Connecting or “internal” pins, mean a frame is made up of multiple bodies, just like a truss. But unlike a truss, the member will not all be *two-force bodies*, so there may be three equations of equilibrium required for each member in an assembly, in addition to the three equations of equilibrium for the entire structure. The force reactions on one side of the pin are equal and opposite those to the other side, so there are only two unknown component forces per pin.

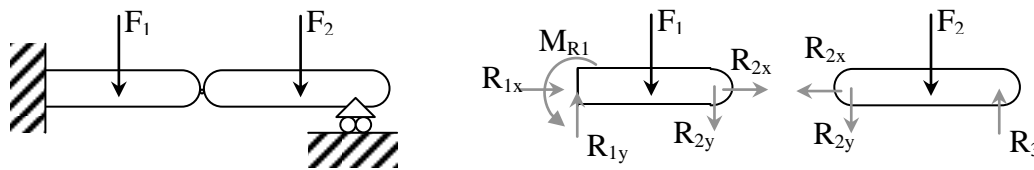

Beam Analysis

Statically determinate beams have a limited number of support arrangements for a limit of three unknown reactions. The cantilever condition has a *reaction moment*.

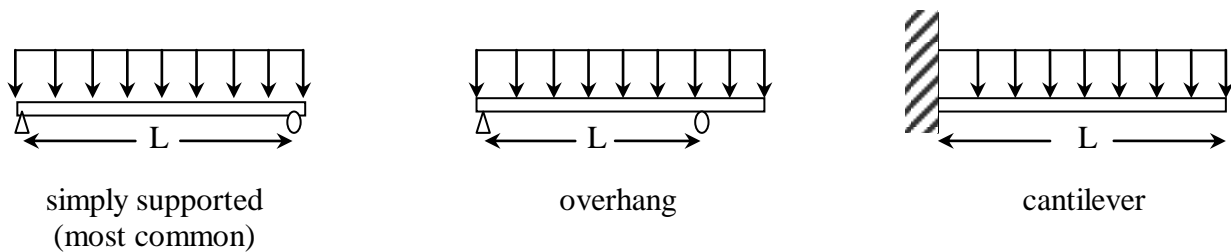

The internal forces and moment are particularly important for design. The axial force (commonly equal zero) is labeled P , while the transverse force is called *shear*, V , and the internal moment is called *bending moment*, M .

The sign convention for *positive shear* is a downward force on a left section cut (or upward force on a right section cut).

The sign convention for *positive bending moment* corresponds to a downward deflection (most common or positive curvature.) That is a *counter clockwise* moment on a right section cut and a *clockwise* moment of a left section cut.

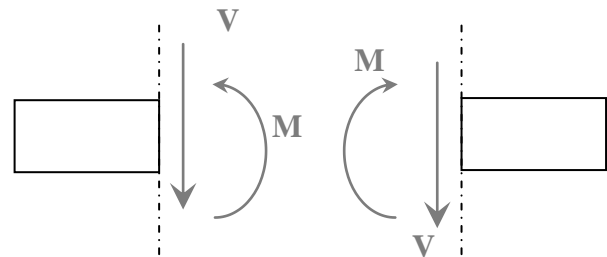

Shear and Bending Moment Diagrams

Diagrams of the internal shear at every location along the beam and of the internal bending moment are extremely useful to locate maximum quantities to design the beams for. There are two primary methods to construct them. The *equilibrium method* relies on section cuts over distances and writes expressions based on the variable of distance. These functions are plotted as lines or curves. The *semi-graphical method* relies on the calculus relationship between the “load” curve (or *load diagram*), shear curve, and bending moment curve. If the area under a curve is known, the result in the next plot is a *change* by the amount of the area.

The location of the **maximum bending moment** corresponds to the location of **zero shear**.

On the deflected shape of a beam, the point where the shape changes from smile up to frown is called the **inflection point**. The bending moment value at this point is **zero**.

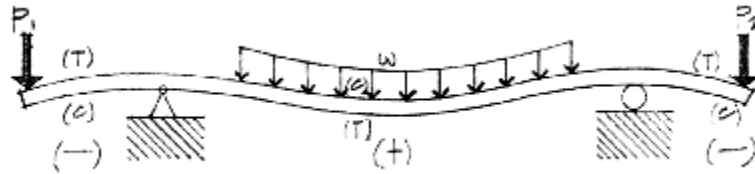

Semigraphical Method Procedure:

1. Find all support forces.

V diagram:

2. At free ends and at simply supported ends, the shear will have a zero value.
3. At the left support, the shear will equal the reaction force.
4. The shear will not change in x until there is another load, where the shear is reduced if the load is negative. If there is a distributed load, the change in shear is the area under the loading.
5. At the right support, the reaction is treated just like the loads of step 4.
6. At the free end, the shear should go to zero.

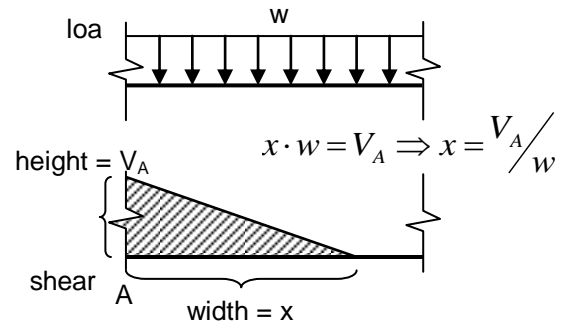

M diagram:

7. At free ends and at simply supported ends, the moment will have a zero value.
8. At the left support, the moment will equal the reaction moment (if there is one).
9. The moment will not change in x until there is another load or applied moment, where the moment is reduced if the applied moment is negative. If there is a value for shear on the V diagram, the change in moment is the area under the shear diagram.

For a triangle in the shear diagram, the width will equal the height \div w !

10. At the right support, the moment reaction is treated just like the moments of step 9.
11. At the free end, the moment should go to zero.

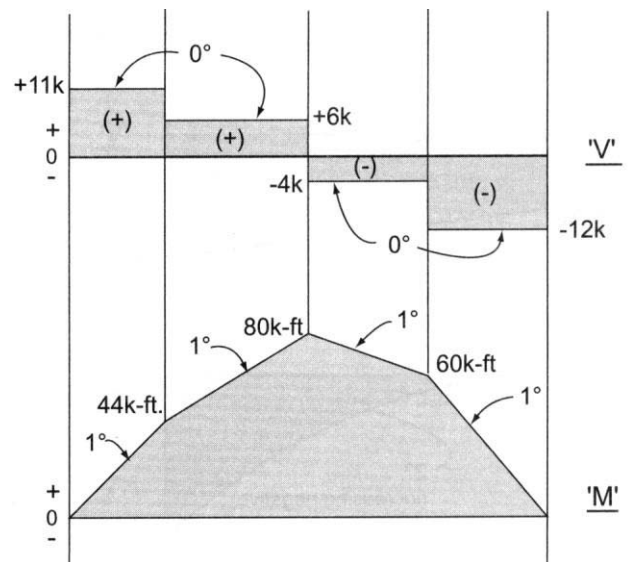

Indeterminate Structures

Structures with more unknowns than equations of equilibrium are *statically indeterminate*. The number of excess equations is the degree to which they are indeterminate. Other methods must be used to generate the additional equation. These structures will usually have *three-force* bodies, and possibly *rigid connections* which mean internal axial, shear and bending moment at the members and at the joints. Bending moment and shear diagrams can be constructed.

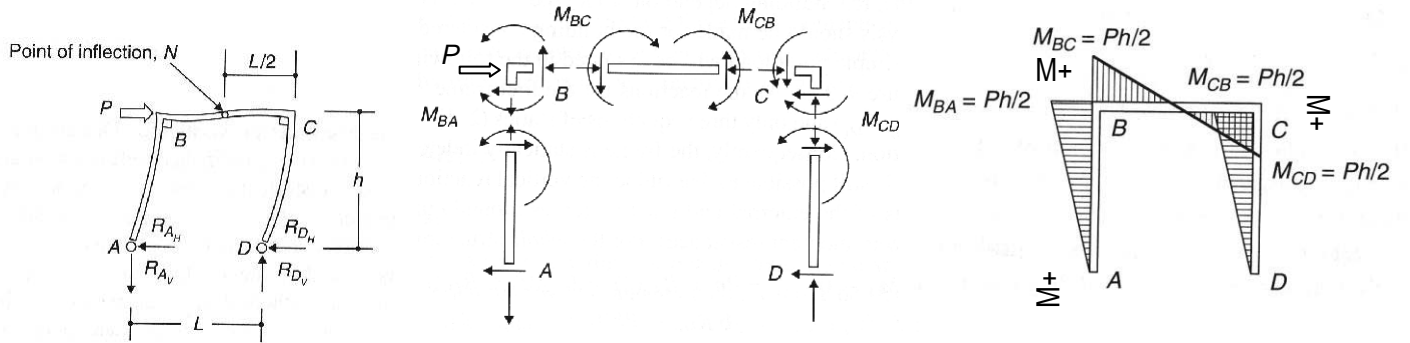

Example 1 Determine the resultant vector analytically with the component method.

Example Problem 2.9 (Figure 2.29)

This is the same problem as Example Problem 2.2, which was solved earlier using the graphical methods.

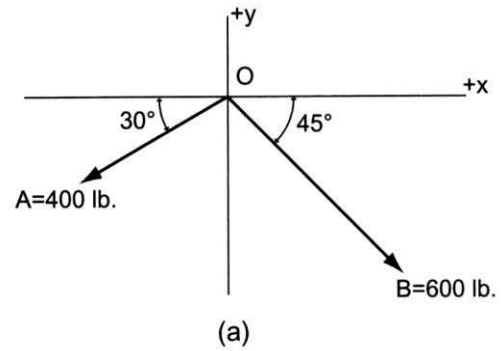

$$\begin{aligned}
 -A_x &= -A \cos 30^\circ = -(400 \text{ lb.})(0.866) = -346.4 \text{ lb.} \\
 -A_y &= -A \sin 30^\circ = -(400 \text{ lb.})(0.50) = -200 \text{ lb.} \\
 +B_x &= +B \cos 45^\circ = +(600 \text{ lb.})(0.707) = +424.2 \text{ lb.} \\
 -B_y &= -B \sin 45^\circ = -(600 \text{ lb.})(0.707) = -424.2 \text{ lb.}
 \end{aligned}$$

$$\begin{aligned}
 R_x &= \sum F_x = -A_x + B_x \\
 &= -346.4 \text{ lb.} + 424.2 \text{ lb.} = +77.8 \text{ lb.}
 \end{aligned}$$

$$\begin{aligned}
 R_y &= \sum F_y = -A_y - B_y \\
 &= -200 \text{ lb.} - 424.2 \text{ lb.} = -624.2 \text{ lb.}
 \end{aligned}$$

$$R = \sqrt{(R_x)^2 + (R_y)^2} = \sqrt{(+77.8)^2 + (-624.2)^2} = 629 \text{ lb.}$$

$$\tan \theta = \left(\frac{R_y}{R_x} \right) \quad \theta = \tan^{-1} \left(\frac{624.2}{77.8} \right) = 82.9^\circ$$

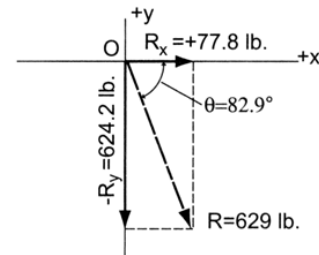
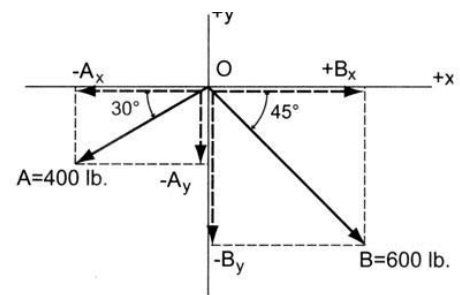

Example 2

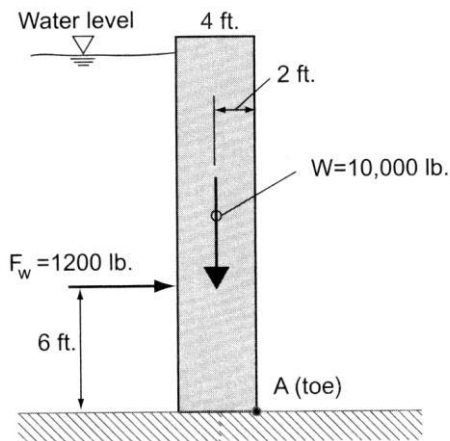

Example Problem 2.13 (Figure 2.35)

A 1-foot-wide slice of a 4-foot-thick concrete gravity dam weighs 10,000 pounds and the equivalent force due to water pressure behind the dam is equal to 1200 pounds. The stability of the dam against overturning is evaluated about the "toe" at A.

Determine the resultant moment at A due to the two forces shown. Is the dam stable?

$$\begin{aligned}
 M_A &= -(F_w) \times (6 \text{ ft.}) + (W) \times (2 \text{ ft.}) \\
 M_A &= -(1200 \text{ lb.})(6 \text{ ft.}) + (10,000 \text{ lb.})(2 \text{ ft.}) \\
 &= +12,800 \text{ lb.-ft.}
 \end{aligned}$$

Yes, because the ground will stop the rotation.

Example 3

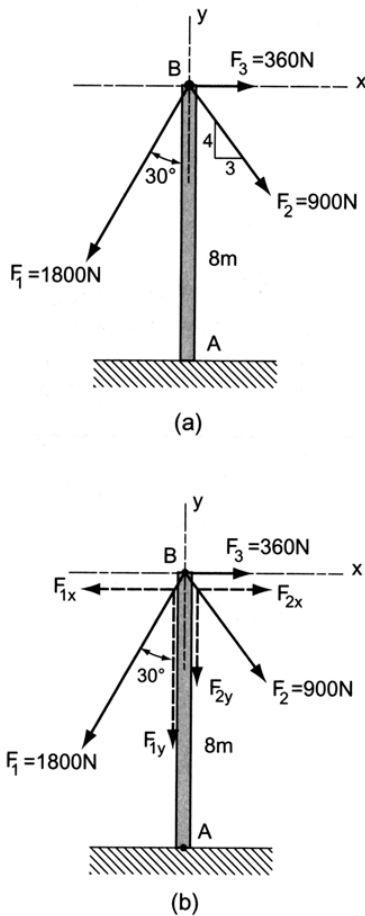

Figure 2.40 (a) Three forces on a vertical pole.
(b) Forces resolved into x and y components.

Example Problem 2.17

A 8-meter vertical pole is used to support three cable forces as shown in Figure 2.40a. Determine the moment at the base of the pole at A.

Solution (Figure 2.40b):

Resolve forces F_1 and F_2 into their respective x and y components.

$$F_{1x} = F_1 \sin 30^\circ = (1800 \text{ N})(0.5) = 900 \text{ N}$$

$$F_{1y} = F_1 \cos 30^\circ = (1800 \text{ N})(0.866) = 1560 \text{ N}$$

$$F_{2x} = \frac{3}{5}F_2 = \frac{3}{5}(900 \text{ N}) = 540 \text{ N}$$

$$F_{2y} = \frac{4}{5}F_2 = \frac{4}{5}(900 \text{ N}) = 720 \text{ N}$$

The moment at the base of the pole at A is the algebraic sum of the moments due to force F_3 and the component forces of F_1 and F_2 .

$$M_A = +(F_{1x})(8 \text{ m}) - (F_{2x})(8 \text{ m}) - (F_3)(8 \text{ m})$$

$$M_A = +(900 \text{ N})(8 \text{ m}) - (540 \text{ N})(8 \text{ m}) - (360 \text{ N})(8 \text{ m})$$

$$M_A = +(7200 \text{ N}\cdot\text{m}) - (4320 \text{ N}\cdot\text{m}) - (2880 \text{ N}\cdot\text{m}) = 0$$

A zero resultant moment at A means that there is no tendency for the pole to rotate about the base for this particular combination of forces. Also, note that the vertical components of forces F_1 and F_2 did not appear in the moment equation because neither had a moment arm.

Forces that intersect the reference point have no moment arms and will cause no tendency for rotation about the point.

Example 4

Example Problem 4.1 (Method of Joints)

An asymmetrical roof truss, shown in Figure 4.4, supports two vertical roof loads. Determine the support reactions at each end, then, Using the method of joints, solve for all member forces. Summarize the results of all member forces on a FBD (this diagram is referred to as a *force summation diagram*).

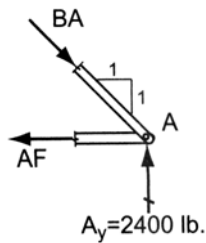
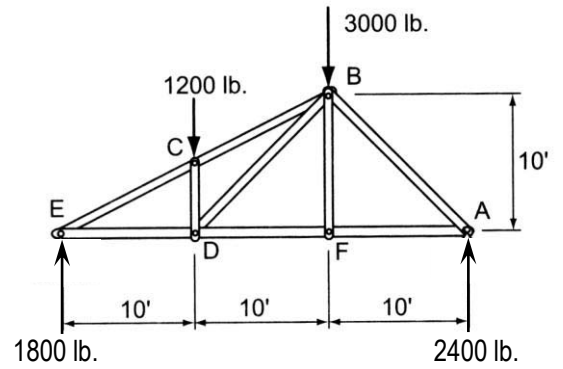

$$\sum F_y = -\left(\frac{BA}{\sqrt{2}}\right) + 2400 \text{ lb.} = 0$$

$$BA = + 2400\sqrt{2} \text{ lb.} = + 3390 \text{ lb.}$$

$$\sum F_x = \left(+\frac{BA}{\sqrt{2}}\right) - AF = 0; \quad AF = \left(+\frac{2400\sqrt{2} \text{ lb.}}{\sqrt{2}}\right) = + 2400 \text{ lb. (tension)}$$

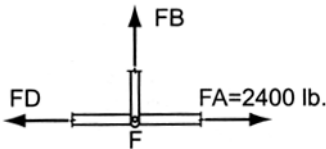

$$\sum F_x = -FD + 2400 \text{ lb.} = 0; \quad FD = + 2400 \text{ lb. (tension)}$$

$$\sum F_y = 0; \quad \therefore FB = 0 \quad \text{special case!}$$

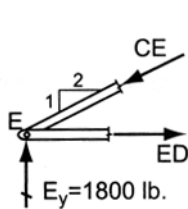

$$\sum F_y = \left(\frac{-CE}{\sqrt{5}}\right) + 1800 \text{ lb.} = 0; \quad CE = + (1800 \text{ lb.})(\sqrt{5}) = + 4025 \text{ lb. (compression)}$$

$$\sum F_x = \left(\frac{-2CE}{\sqrt{5}}\right) + ED = 0; \quad ED = + \left(\frac{2 \times 4025 \text{ lb.}}{\sqrt{5}}\right) = + 3600 \text{ lb. (tension)}$$

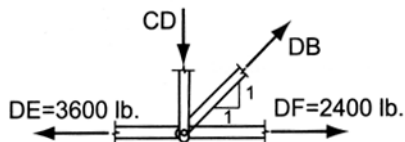

$$\sum F_x = (-3600 \text{ lb.}) + (2400 \text{ lb.}) + \left(\frac{DB}{\sqrt{2}}\right) = 0$$

$$DB = (1200\sqrt{2} \text{ lb.}) = + 1696 \text{ lb. (tension)}$$

$$\sum F_y = +DB_y - CD = 0 \quad CD = \frac{DB}{\sqrt{2}} = \frac{1200\sqrt{2} \text{ lb.}}{\sqrt{2}} = 1200 \text{ lb. (compression)}$$

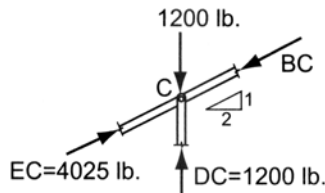

$$\sum F_x = +EC_x - BC_x = 0$$

$$BC_x = \frac{2BC}{\sqrt{5}} \text{ and } EC_x = \frac{(2 \times 4025 \text{ lb.})}{\sqrt{5}} = 3600 \text{ lb.}$$

$$\sum F_y = \left(+\frac{4025 \text{ lb.}}{\sqrt{5}}\right) - 1200 \text{ lb.} + 1200 \text{ lb.} - \left(\frac{4025 \text{ lb.}}{\sqrt{5}}\right) = 0$$

$$0 = 0; \quad \text{checks}$$

Example 5

Figure 3.15 shows a radial three-hinged arch, so named because the shape of the two-member structure is an arc of a circle with a 42-ft radius that is pinned at its two external supports with a third pin connecting the two members at the crown of the arch. Such frames are commonly used to form circular dome and barrel arch buildings and, as in this case, arch bridges.

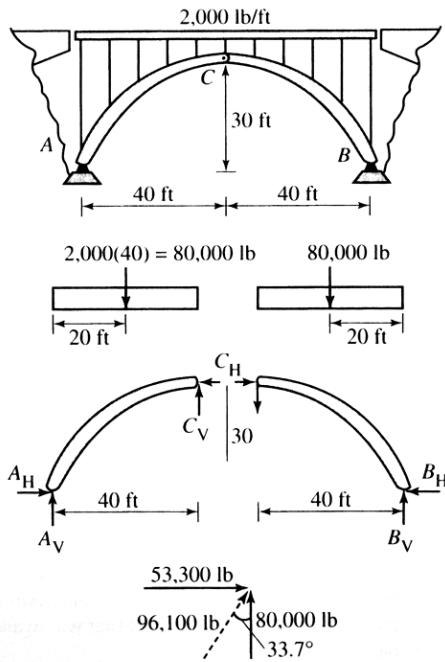

FIGURE 3.15

This bridge structure consists of four arches spaced 18 ft apart, with each supporting a roadway deck having a uniform dead (including allowance for the arch self-weight) plus averaged live load of 2,000 plf. As shown, this horizontal load is delivered to the arch through vertical columns spaced 8 ft apart, each delivering the same vertical load to the supporting arch. In this instance, or whenever four or more uniformly spaced equal concentrated loads act on a structural element, it is reasonable to assume the element is uniformly loaded.

We want to know the external reaction components at supports *A* and *B*. Since there are four support reactions—two per hinge—we cannot simply determine them by application of the three equilibrium equations to the entire 80-ft structure. By taking it apart at pin *C*, however, we see that we have a total of six unknowns (two per pin) and three equations of equilibrium for each of the two separated members—six equations and six unknowns. Note that the two components of the force in hinge *C* must be assumed to be equal and opposite on the left and right members.

By summing moments at *A* and *B*, respectively, we get the following two equations with the two unknown components of force in pin *C*:

$$80,000(20) - C_{11}(30) - C_V(40) = 0$$

$$-80,000(20) + C_{11}(30) - C_V(40) = 0$$

From these, $C_{11} = 53,300$ lb and $C_V = 0$. Summing vertical forces on each arch element shows us that $A_V = B_V = 80,000$ lb, and summation of horizontal forces on both members indicates that the outward kick of the arch members, called the horizontal thrust, is

$$A_{11} = B_{11} = C_{11} = 53,300 \text{ lb}$$

Thus, the force with which the foundation reacts to support the arch bridge is given as

$$F = \sqrt{(80,000^2 + 53,300^2)} = 96,100 \text{ lb}$$

This force makes an angle with a vertical axis of

$$z = \arctan\left(\frac{53,300}{80,000}\right) = 33.7^\circ$$

Actually, we could have made quick work of determining the arch reaction components by applying the simple arch equations discussed in the last chapter. Since it is uniformly loaded, the vertical component of the reaction at *A* would be $V = wL/2 = 2000(80)/2 = 80,000$ lb. The horizontal component would be $H = wL^2/8s = 2000(80^2)/(8 \times 30) = 53,300$ lb.

Example 6

Example Problem 8.5 (Semi-Graphical Method)

A cantilever beam supports a uniform load of $\omega = 2 \text{ kN/m}$ over its entire span, plus a concentrated load of 10 kN at 0.75 m from the free end. Construct the V and M diagrams (Figure 8.29).

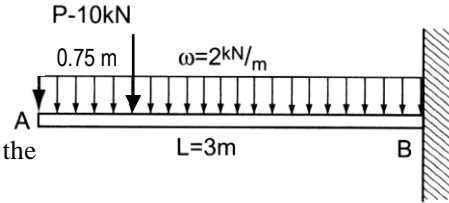

SOLUTION:
Determine the reactions:

$$\begin{aligned} \sum F_x &= R_{Bx} = 0 & R_{Bx} &= 0 \text{ kN} \\ \sum F_y &= -10\text{kN} - (2\text{kN/m})(3\text{m}) + R_{By} = 0 & R_{By} &= 16 \text{ kN} \\ \sum M_B &= (10\text{kN})(2.25\text{m}) + (6\text{kN})(1.5\text{m}) + M_{RB} = 0 & M_{RB} &= -31.5\text{kN}\cdot\text{m} \end{aligned}$$

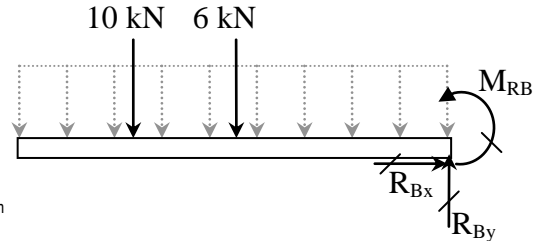

Draw the load diagram with the distributed load as given with the reactions.

Shear Diagram:

Label the load areas and calculate:

$$\begin{aligned} \text{Area I} &= (-2 \text{ kN/m})(0.75 \text{ m}) = -1.5 \text{ kN} \\ \text{Area II} &= (-2 \text{ kN/m})(2.25 \text{ m}) = -4.5 \text{ kN} \\ V_A &= 0 \\ V_C &= V_A + \text{Area I} = 0 - 1.5 \text{ kN} = -1.5 \text{ kN} \text{ and} \\ V_C &= V_C + \text{force at C} = -1.5 \text{ kN} - 10 \text{ kN} = -11.5 \text{ kN} \\ V_B &= V_C + \text{Area II} = -11.5 \text{ kN} - 4.5 \text{ kN} = -16 \text{ kN} \text{ and} \\ V_B &= V_B + \text{force at B} = -16 \text{ kN} + 16 \text{ kN} = 0 \text{ kN} \end{aligned}$$

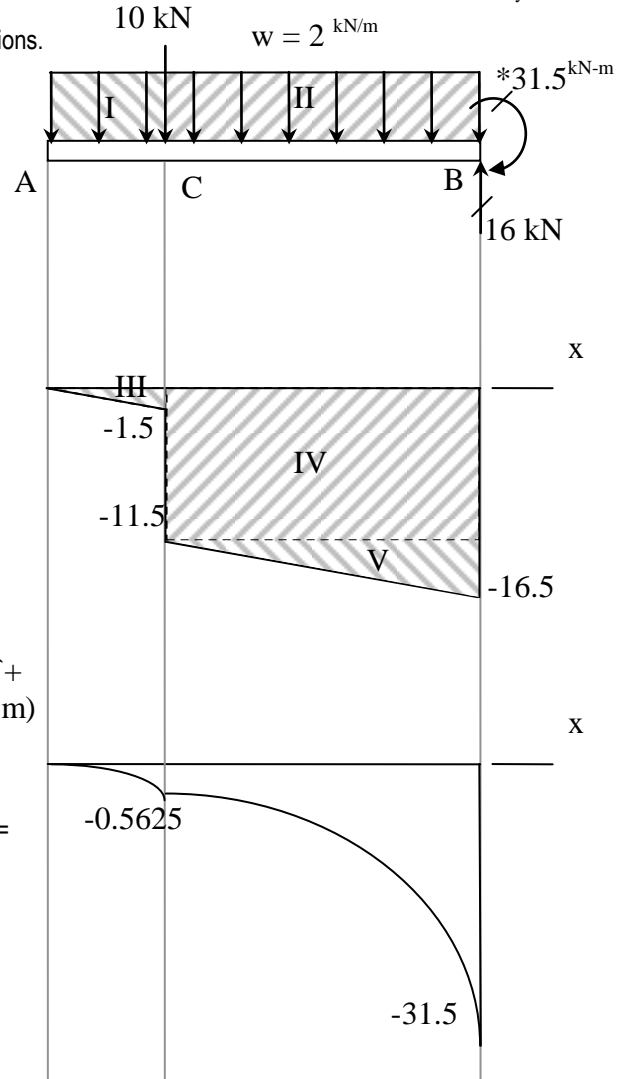

Bending Moment Diagram:

Label the load areas and calculate:

$$\begin{aligned} \text{Area III} &= (-1.5 \text{ kN})(0.75 \text{ m})/2 = -0.5625 \text{ kN}\cdot\text{m} \\ \text{Area IV} &= (-11.5 \text{ kN})(2.25\text{m}) = -25.875 \text{ kN}\cdot\text{m} \\ \text{Area V} &= (-16 - 11.5 \text{ kN})(2.25\text{m})/2 = -5.0625 \text{ kN}\cdot\text{m} \\ M_A &= 0 \\ M_C &= M_A + \text{Area III} = 0 - 0.5625 \text{ kN}\cdot\text{m} = -0.5625 \text{ kN}\cdot\text{m} \\ M_B &= M_C + \text{Area IV} + \text{Area V} = -0.5625 \text{ kN}\cdot\text{m} - 25.875 \text{ kN}\cdot\text{m} - 5.0625 \text{ kN}\cdot\text{m} = \\ &= -31.5 \text{ kN}\cdot\text{m} \text{ and} \\ M_B &= M_B + \text{moment at B} = -31.5 \text{ kN}\cdot\text{m} + 31.5 \text{ kN}\cdot\text{m} = 0 \text{ kN}\cdot\text{m} \end{aligned}$$

