

lecture
twenty four



<http://nisee.berkeley.edu/godden>

concrete construction: flat spanning systems

Concrete Spans 1
Lecture 24

Elements of Architectural Structures
ARCH 614

S2009abn

Reinforced Concrete Design

- economical & common
- resist lateral loads

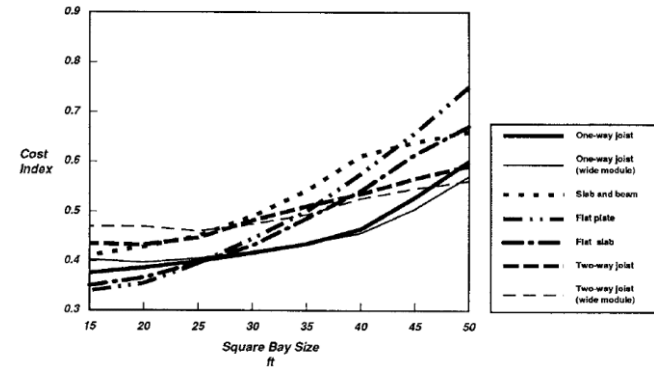

Concrete Spans 2
Lecture 24

Elements of Architectural Structures
ARCH 614

S2007abn

Reinforced Concrete Design

- flat plate
 - 5"-10" thick
 - simple formwork
 - lower story heights

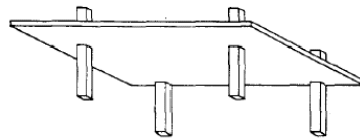

- flat slab
 - same as plate
 - 2 1/4"-8" drop panels

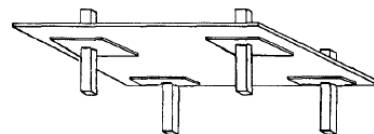

Concrete Spans 3
Lecture 24

Elements of Architectural Structures
ARCH 614

S2007abn

Reinforced Concrete Design

- beam supported
 - slab depth ~ $L/20$
 - 8"-60" deep
- one-way joists
 - 3"-5" slab
 - 8"-20" stems
 - 5"-7" webs

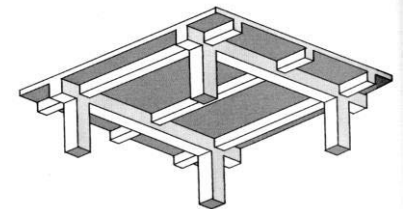

The Architect's Studio Companion

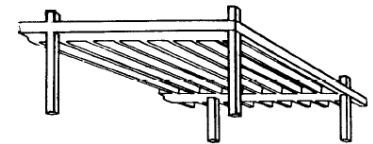

Concrete Spans 4
Lecture 24

Elements of Architectural Structures
ARCH 614

S2007abn

Reinforced Concrete Design

- two-way joist
 - “waffle slab”
 - 3”-5” slab
 - 8”-24” stems
 - 6”-8” webs
- beam supported slab
 - 5”-10” slabs
 - taller story heights

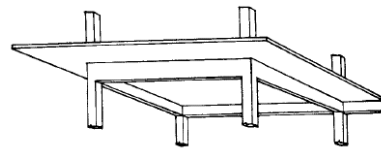
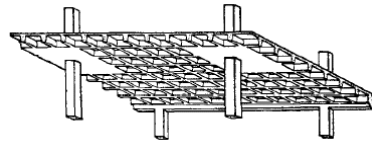

Reinforced Concrete Design

- simplified frame analysis
 - strips, like continuous beams
- moments require flexural reinforcement
 - top & bottom
 - both directions of slab
 - continuous, bent or discontinuous

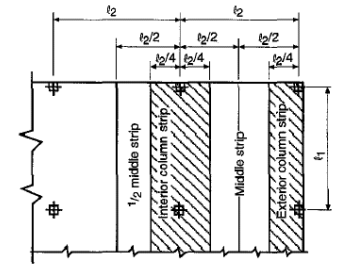

(a) Column strip for $l_2 \leq l_1$

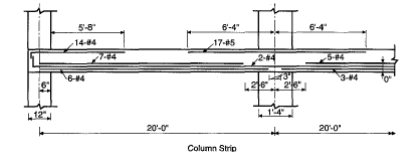

Column Strip

Reinforced Concrete Design

- one-way slabs (wide beam design)
 - approximate analysis for moment & shear coefficients
 - two or more spans
 - ~ same lengths
 - w_u from combos
 - uniform loads with $L/D \leq 3$
 - l_n is clear span (+M) or average of adjacent clear spans (-M)

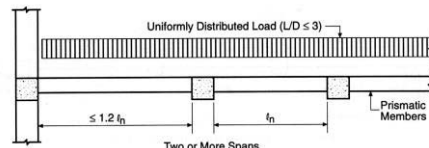

Figure 2-2 Conditions for Analysis by Coefficients (ACI 8.3.3)

Reinforced Concrete Design

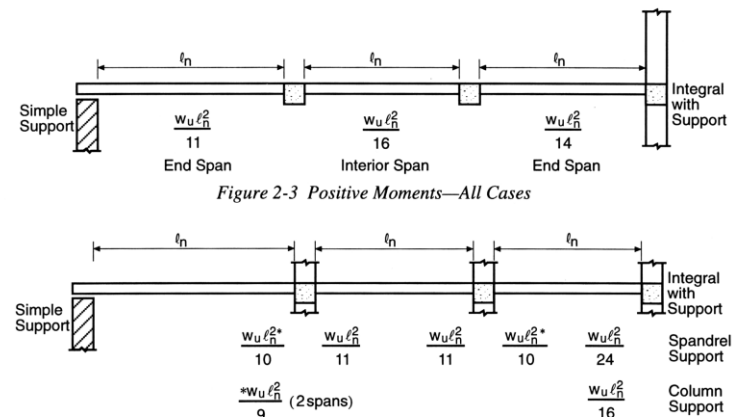
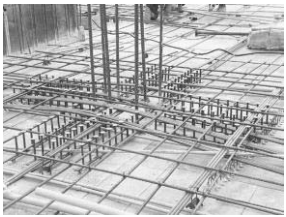

Figure 2-4 Negative Moments—Beams and Slabs

Shear in Concrete

- at columns
- want to avoid stirrups
- can use shear studs or heads



Concrete Spans 9
Lecture 24

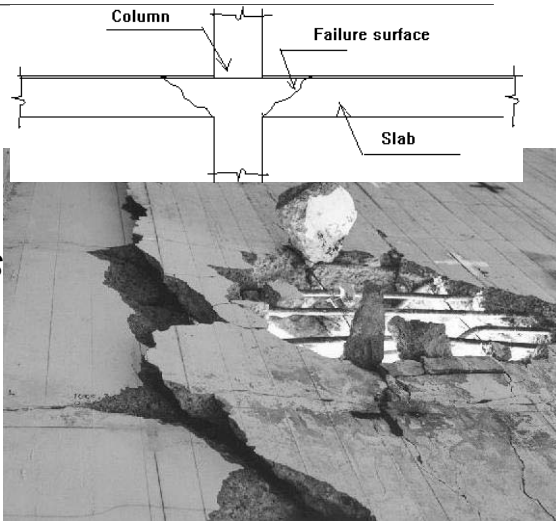

Elements of Architectural Structures
ARCH 614

S2007abn

Shear in Concrete

- critical section at $d/2$ from
 - column face, column capital or drop panel

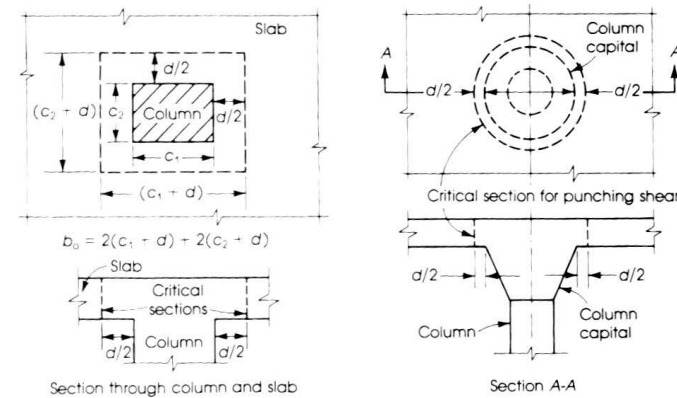

Concrete Spans 10
Lecture 24

Elements of Architectural Structures
ARCH 614

S2007abn

Shear in Concrete

- at columns with waffle slabs

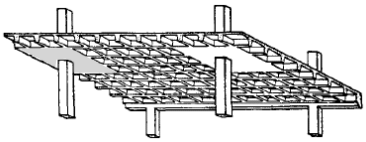

Concrete Spans 11
Lecture 24

Elements of Architectural Structures <http://nisee.berkeley.edu/godden> S2007abn
ARCH 614

Openings in Slabs

- careful placement of holes
- shear strength reduced
- bending & deflection can increase

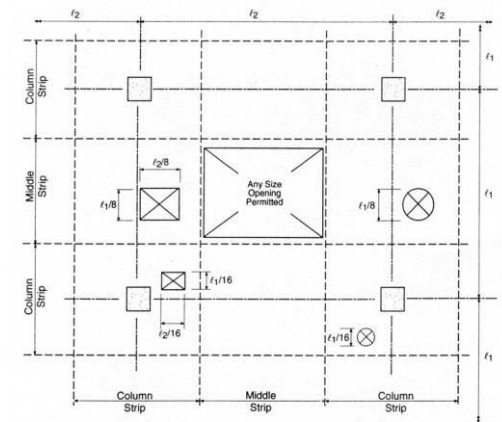

Figure 18-11 Openings in Slab Systems without Beams

Concrete Spans 12
Lecture 24

Elements of Architectural Structures
ARCH 614

S2007abn

General Beam Design

- f'_c & f_y needed
- usually size just b & h
 - even inches typical (forms)
 - similar joist to beam depth
 - $b:h$ of 1:1.5-1:2.5
 - b_w & b_f for T
 - to fit reinforcement + stirrups
- slab design, t
 - deflection control & shear

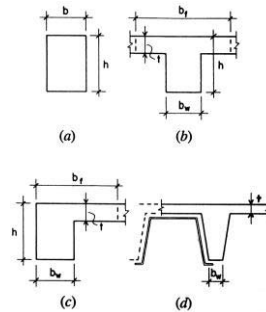

Figure 14.5 Common shapes for beams.

$$S = \frac{bh^2}{6}$$

General Beam Design (cont'd)

- custom design:
 - longitudinal steel
 - shear reinforcement
 - detailing

