

ELEMENTS OF ARCHITECTURAL STRUCTURES:  
FORM, BEHAVIOR, AND DESIGN

ARCH 614

DR. ANNE NICHOLS

SPRING 2013

lecture  
eleven

rigid frames:  
compression & bending



Rigid Frames 1  
Lecture 11

Elements of Architectural Structures  
ARCH 614 <http://nisee.berkeley.edu/godden> S2009abn

Rigid Frames

- rigid frames have no pins
- frame is all one body
- joints transfer moments and shear
- typically statically indeterminate
- types
  - portal
  - gable

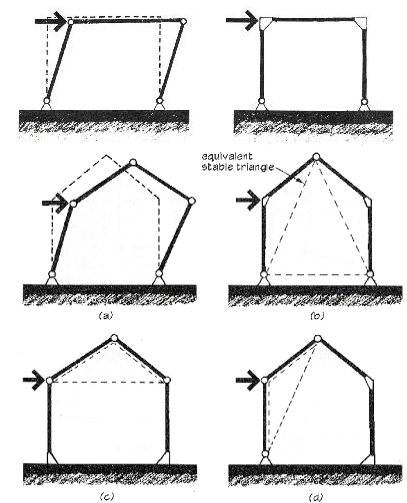

Rigid Frames 8  
Lecture 25

Elements of Architectural Structures  
ARCH 614

S2004abn

Rigid Frames

- behavior

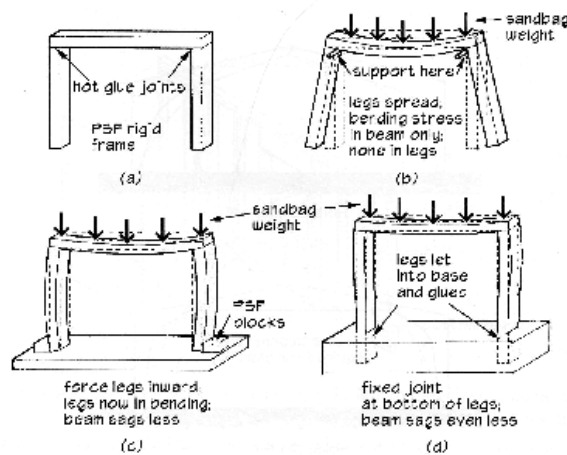

Rigid Frames 9  
Lecture 25

Elements of Architectural Structures  
ARCH 614

S2004abn

Rigid Frames

- moments get redistributed
- deflections are smaller
- effective column lengths are shorter
- very sensitive to settling

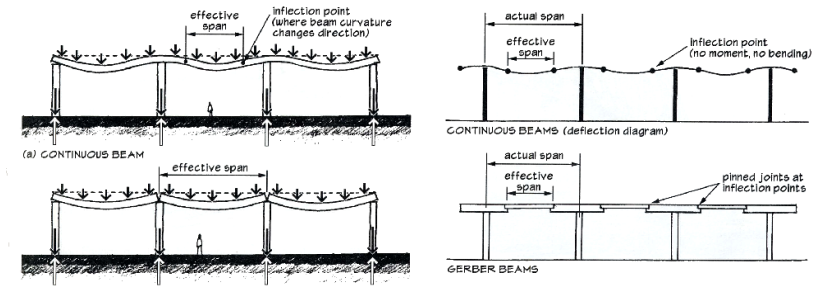

(b) SIMPLE BEAM  
Rigid Frames 10  
Lecture 25

Elements of Architectural Structures  
ARCH 614

S2004abn

# Rigid Frames

- resists lateral loadings
- shape depends on stiffness of beams and columns
- 90° maintained

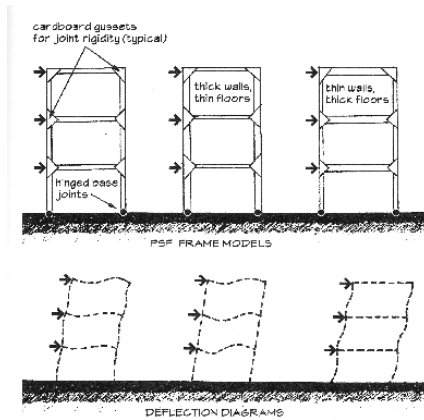
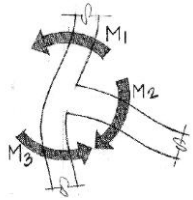

Figure 9.19: Modal demonstration of the effects of varying the stiffness of beams and columns when a building frame is subjected to lateral loads.

Rigid Frames 11  
Lecture 25

Elements of Architectural Structures  
ARCH 614

S2004abn

# Rigid Frames

- staggered truss
  - rigidity
  - clear stories

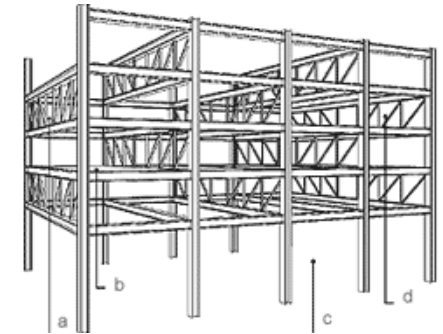

Rigid Frames 12  
Lecture 25

Elements of Architectural Structures  
ARCH 614

S2004abn

# Rigid Frames

- connections
  - steel
  - concrete

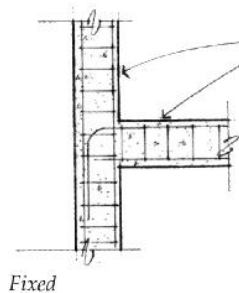
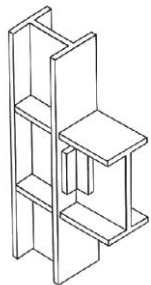

<http://nisee.berkeley.edu/godden>

Rigid Frames 13  
Lecture 25

Elements of Architectural Structures  
ARCH 614

S2004abn

# Braced Frames

- pin connections
- bracing to prevent lateral movements



<http://nisee.berkeley.edu/godden>

Rigid Frames 14  
Lecture 25

Elements of Architectural Structures  
ARCH 614

S2004abn

## Braced Frames

- types of bracing
  - knee-bracing
  - diagonal
  - X
  - K or chevron
  - shear walls

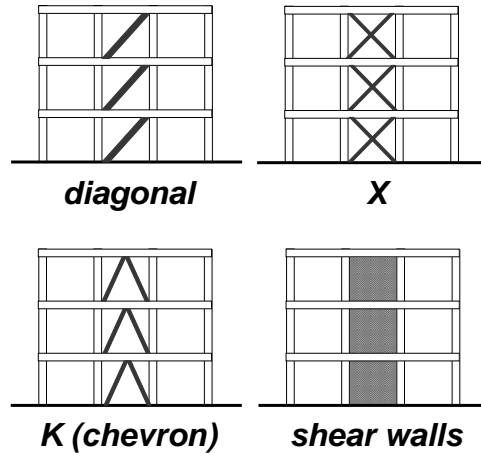
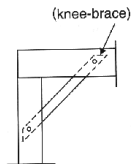

Rigid Frames 15  
Lecture 25

Elements of Architectural Structures  
ARCH 614

S2004abn

## Shear Walls

- resist lateral load in plane with wall

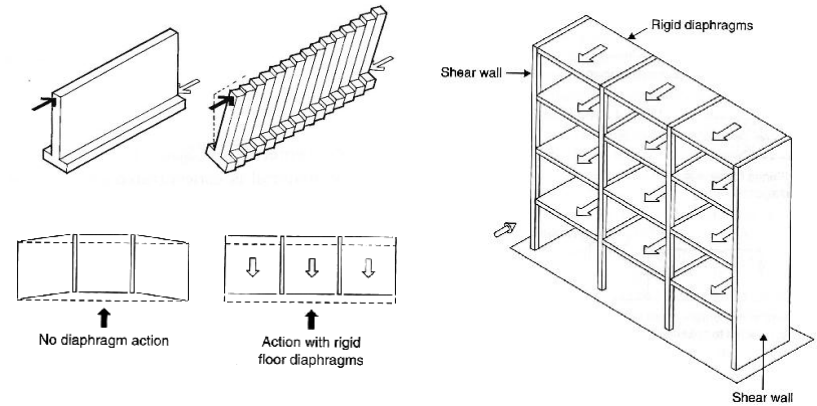

Rigid Frames 16  
Lecture 25

Elements of Architectural Structures  
ARCH 614

S2004abn

## Compression Members

- designed for strength & stresses
- designed for serviceability & deflection
- need to design for stability
  - ability to support a specified load without sudden or unacceptable deformations

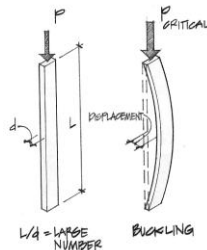

Stability and Columns 9  
Lecture 22

Elements of Architectural Structures  
ARCH 614

S2004abn

## Column Buckling

- axially loaded columns
- long & slender
  - unstable equilibrium = buckling
  - sudden and not good



Stability and Columns 14  
Lecture 22

Elements of Architectural Structures  
ARCH 614

S2004abn

# Modeling

- can be modeled with a spring at mid-height
- when moment from deflection exceeds the spring capacity ... “boing”
- critical load  $P$

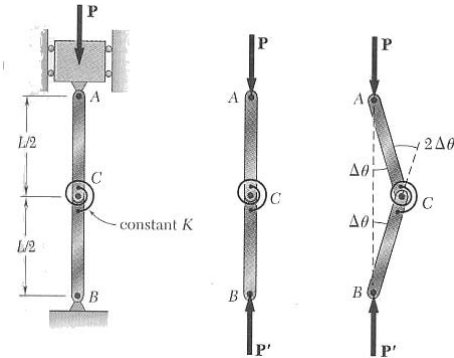

Stability and Columns 15  
Lecture 22

Elements of Architectural Structures  
ARCH 614

S2004abn

# Effect of Length

- long & slender
- short & stubby

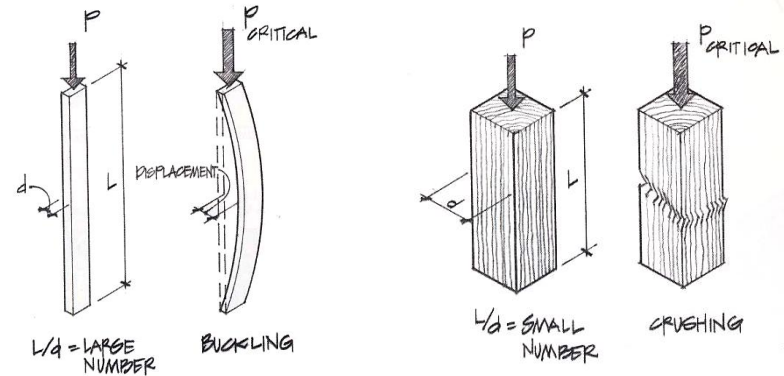

Stability and Columns 16  
Lecture 22

Elements of Architectural Structures  
ARCH 614

S2004abn

# Buckling Load

- related to deflected shape ( $P\Delta$ )
- shape of sine wave
- Euler’s Formula
- smallest  $I$  governs

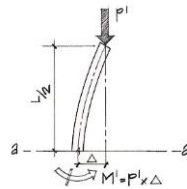

$$P_{critical} = \frac{\pi^2 EI}{(L)^2}$$



Figure 9.3 Leonhard Euler (1707–1783).

Stability and Columns 17  
Lecture 22

Elements of Architectural Structures  
ARCH 614

S2004abn

# Critical Stress

- short columns

$$f_{critical} = \frac{P_{actual}}{A} < F_a$$

- slenderness ratio =  $L_e/r$  ( $L/d$ )

- radius of gyration =  $r = \sqrt{\frac{I}{A}}$

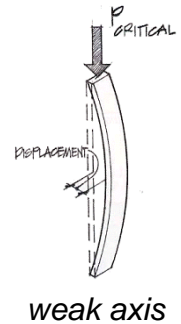

$$f_{critical} = \frac{P_{critical}}{A} = \frac{\pi^2 EAr^2}{A(L_e)^2} = \frac{\pi^2 E}{\left(\frac{L_e}{r}\right)^2} \quad P_{critical} = \frac{\pi^2 EA}{\left(\frac{L_e}{r}\right)^2}$$

Stability and Columns 18  
Lecture 22

Elements of Architectural Structures  
ARCH 614

S2004abn

# Critical Stresses

- when a column gets stubby,  $F_y$  will limit the load for steel
- real world has loads with eccentricity

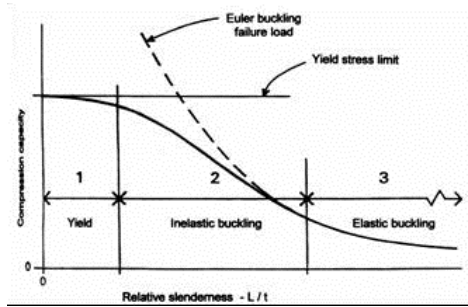

Stability and Columns 19  
Lecture 22

Elements of Architectural Structures  
ARCH 614

S2004abn

# Effective Length

- end conditions affect shape
- effective length factor,  $K$   $L_e = K \cdot L$

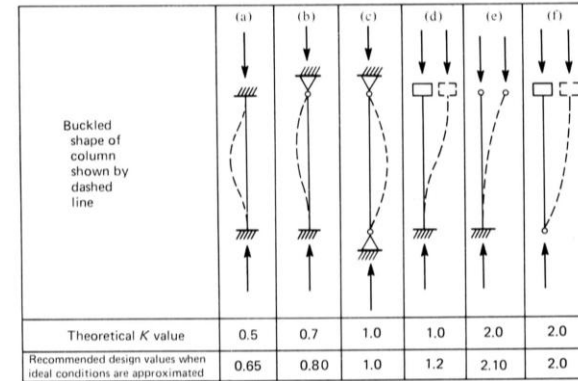

Stability and Columns 20  
Lecture 22

Elements of Architectural Structures  
ARCH 614

S2004abn

# Bracing

- bracing affects shape of buckle in one direction
- both should be checked!

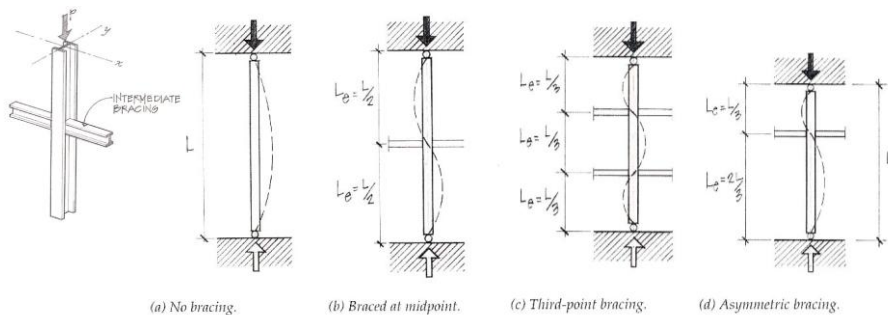

Stability and Columns 21  
Lecture 22

Elements of Architectural Structures  
ARCH 614

S2004abn

# Centric & Eccentric Loading

- centric
  - allowable stress from strength or buckling
- eccentric
  - combined stresses

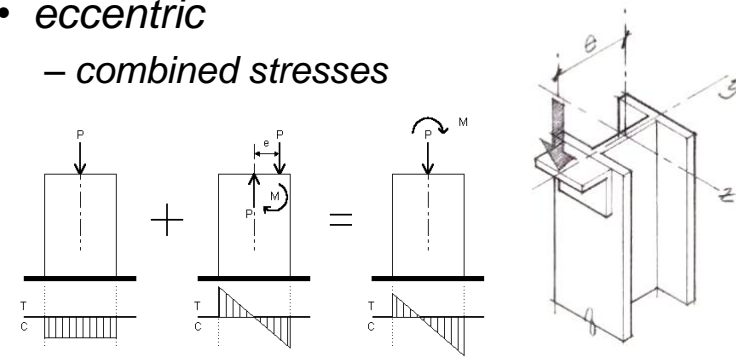

Column Eccentricity 18  
Lecture 23

Elements of Architectural Structures  
ARCH 614

S2004abn

## Combined Stresses

- axial + bending

$$f_{\max} = \frac{P}{A} + \frac{Mc}{I}$$

$$M = P \cdot e$$

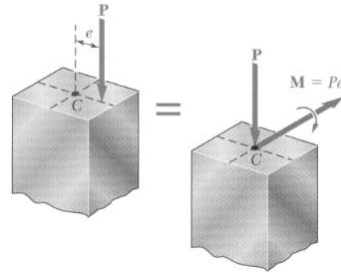

- design

$$f_{\max} \leq F_{cr} = \frac{f_{cr}}{F.S.}$$

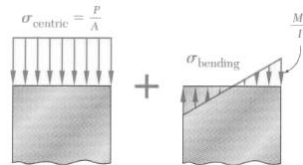

Column Eccentricity 19  
Lecture 23

Elements of Architectural Structures  
ARCH 614

S2004abn

## Stress Limit Conditions

- ASD interaction formula

$$\frac{f_a}{F_a} + \frac{f_b}{F_b} \leq 1.0$$

- with biaxial bending

$$\frac{f_a}{F_a} + \frac{f_{bx}}{F_{bx}} + \frac{f_{by}}{F_{by}} \leq 1.0$$

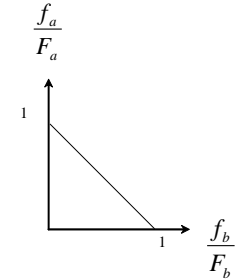

interaction diagram

Column Eccentricity 22  
Lecture 23

Elements of Architectural Structures  
ARCH 614

S2004abn

## Stress Limit Conditions

- in reality, as the column flexes,  
the moment increases

- P-Δ effect

$$\frac{f_a}{F_a} + \frac{f_b \times (\text{Magnification factor})}{F_{bx}} \leq 1.0$$

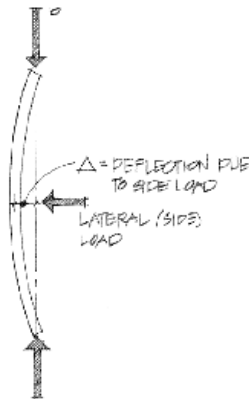

Column Eccentricity 23  
Lecture 23

Elements of Architectural Structures  
ARCH 614

S2004abn

## Rigid Frame Analysis

- members see
  - shear
  - axial force
  - bending
- V & M diagrams
  - plot on "outside"

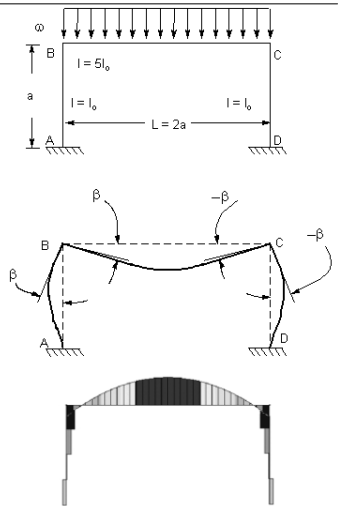

Rigid Frames 17  
Lecture 25

Elements of Architectural Structures  
ARCH 614

S2004abn

# Rigid Frame Analysis

- need support reactions
- free body diagram each member
- end reactions are equal and opposite on next member
- “turn” member like beam
- draw V & M

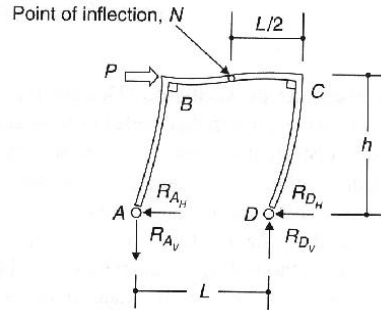

Rigid Frames 18  
Lecture 25

Elements of Architectural Structures  
ARCH 614

S2004abn

# Rigid Frame Analysis

- FBD & M
- opposite end reactions at joints

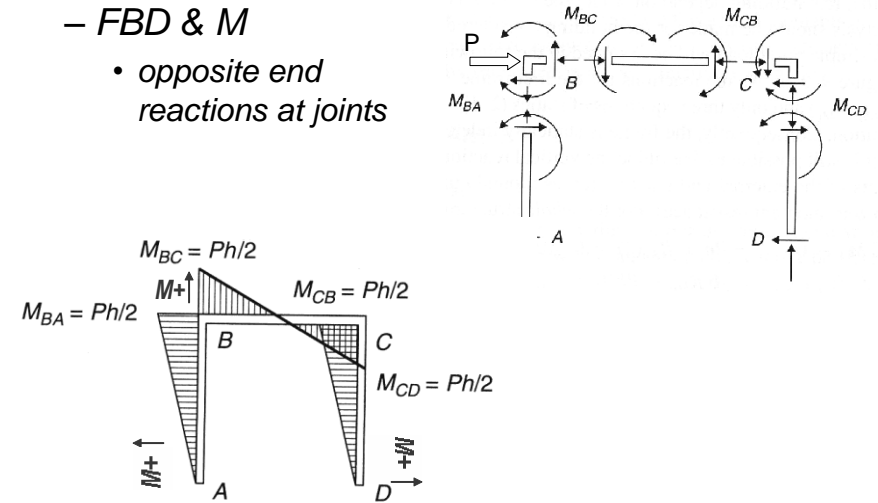

Rigid Frames 19  
Lecture 25

Elements of Architectural Structures  
ARCH 614

S2004abn

# Rigid Frame Design

- columns in frames
- ends can be “flexible”
- stiffness affected by beams and column =  $EI/L$

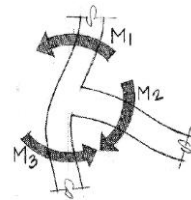

$$G = \Psi = \frac{\sum EI/l_c}{\sum EI/l_b}$$

- for the joint
  - $l_c$  is the column length of each column
  - $l_b$  is the beam length of each beam
  - measured center to center

Rigid Frames 24  
Lecture 25

Elements of Architectural Structures  
ARCH 614

S2004abn

# Rigid Frame Design

- column effective length,  $k$

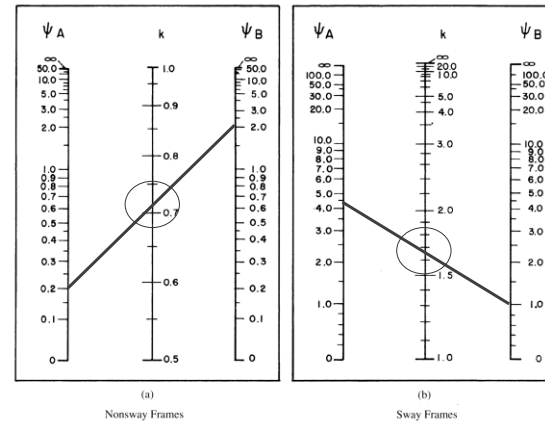

(a) Nonsway Frames

(b) Sway Frames

Rigid Frames 19  
Lecture 26

Elements of Architectural Structures  
ARCH 614

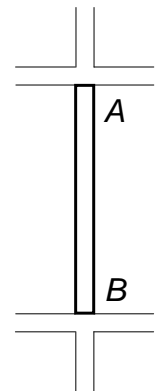

S2006abn

## Tools – Multiframe

- in computer lab

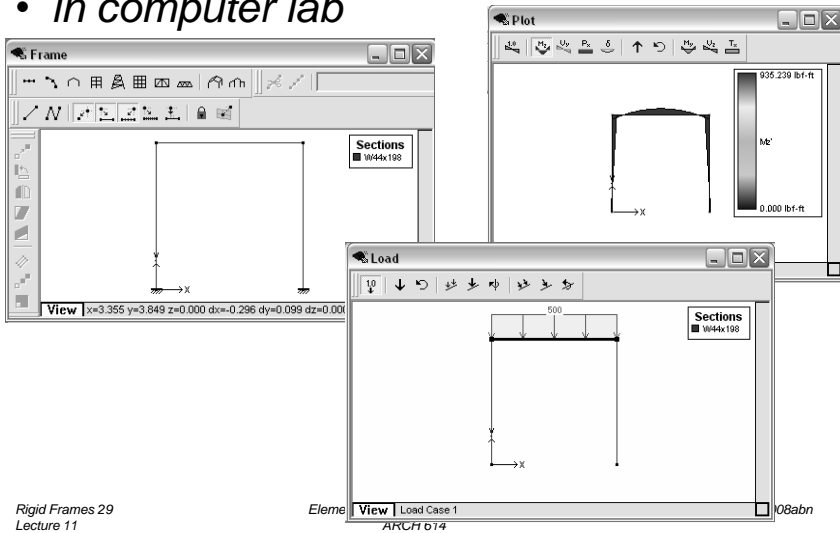

Rigid Frames 29  
Lecture 11

Elernel View Load Case 1 ARCH 614 08abn

## Tools – Multiframe

- frame window
  - define frame members
    - or pre-defined frame
  - select points, assign supports
  - select members, assign section
  - load window
  - select point or member, add point or distributed loads

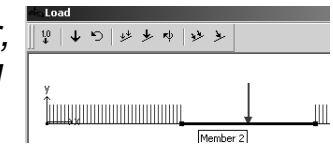
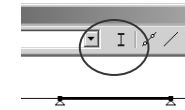
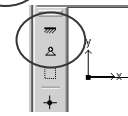
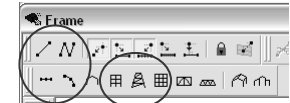

Rigid Frames 30  
Lecture 11

Elements of Architectural Structures  
ARCH 614

S2008abn

## Tools – Multiframe

- to run analysis choose
  - Analyze menu
    - Linear
- plot
  - choose options
- results
  - choose options

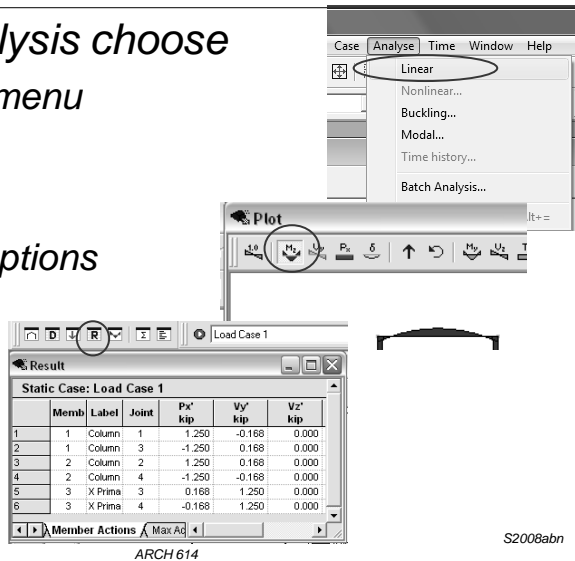

Rigid Frames 31  
Lecture 11

ARCH 614

S2008abn