

ELEMENTS OF ARCHITECTURAL STRUCTURES:

FORM, BEHAVIOR, AND DESIGN

ARCH 614

DR. ANNE NICHOLS

SPRING 2013

**lecture
one**

**behavior and design
of structures**



Introduction 1
Lecture 1

Elements of Architectural Structures
ARCH 614

www.greatbuildings.com
S2009abn

Course Description

- **statics**
 - physics of forces and reactions on bodies and systems
 - equilibrium (bodies at rest)
- **structures**
 - something made up of interdependent parts in a definite pattern of organization
- **design**
 - assessing and meeting structural requirements of parts and the whole

Introduction 3
Lecture 1

Elements of Architectural Structures
ARCH 614

S2006abn

Syllabus & Student Understandings

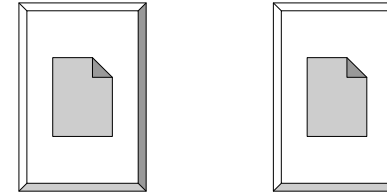

Introduction 2
Lecture 1

Elements of Architectural Structures
ARCH 614

S2005abn

Course Description

- **mechanics of materials**
 - external loads and effect on deformable bodies
 - use it to answer question if structure meets requirements of
 - stability and equilibrium
 - strength and stiffness
 - other principle building requirements
 - economy, functionality and aesthetics

Introduction 4
Lecture 1

Elements of Architectural Structures
ARCH 614

S2005abn

Structure Requirements

- *stability & equilibrium*
– *STATICS*

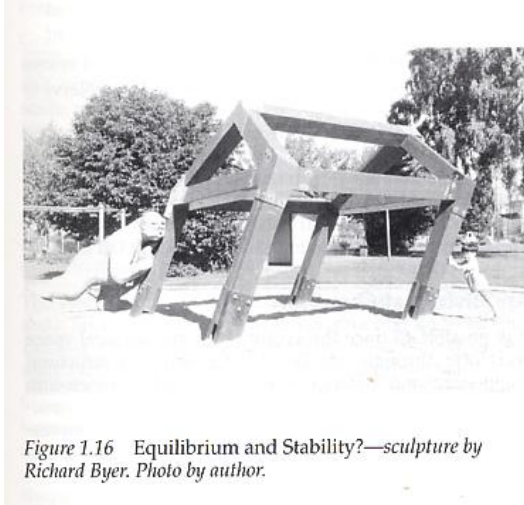

Figure 1.16 Equilibrium and Stability?—sculpture by Richard Byer. Photo by author.

Introduction 5
Lecture 1

Elements of Architectural Structures
ARCH 614

S2005abn

Structure Requirements (cont)

- *strength & stiffness*
– *concerned with stability of components*



Figure 1.15 Stability and the strength of a structure—the collapse of a portion of the UW Husky stadium during construction (1987) due to a lack of adequate bracing to ensure stability. Photo by author.

Introduction 6
Lecture 1

Elements of Architectural Structures
ARCH 614

S2005abn

Structural System Selection

- *kind & size of loads*
- *building function*
- *soil & topology of site*
- *systems integration*
- *fire rating*
- *construction (\$\$, schedule)*
- *architectural form*

Introduction 7
Lecture 1

Elements of Architectural Structures
ARCH 614

S2006abn

Knowledge Required

- *external forces*
- *internal forces*
- *material properties*
- *member cross sections*
- *ability of a material to resist breaking*
- *structural elements that resist excessive*
– *deflection*
– *deformation*

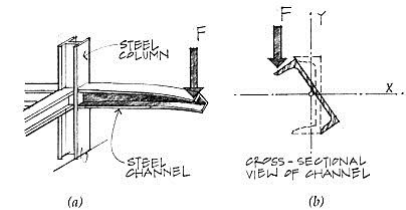

Figure 2.34 An example of torsion on a cantilever beam.

Introduction 7
Lecture 1

Elements of Architectural Structures
ARCH 614

S2005abn

Problem Solving

1. STATICS:

equilibrium of external forces,
internal forces, stresses

2. GEOMETRY:

cross section properties, deformations and
conditions of geometric fit, strains

3. MATERIAL PROPERTIES:

stress-strain relationship for each material
obtained from testing



Relation to Architecture

“The geometry and arrangement of the load-bearing members, the use of materials, and the crafting of joints all represent opportunities for buildings to express themselves. The best buildings are not designed by architects who after resolving the formal and spatial issues, simply ask the structural engineer to make sure it doesn’t fall down.” -Onouye & Kane

*Statics and Strength of Materials for
Architecture and Building Construction*

Architectural Structures

- *incorporates*
 - *stability and equilibrium*
 - *strength and stiffness*
 - *economy, functionality and aesthetics*
- *uses*
 - *sculpture*
 - *furniture*
 - *buildings*



*The “Fist”
Detroit, MI*

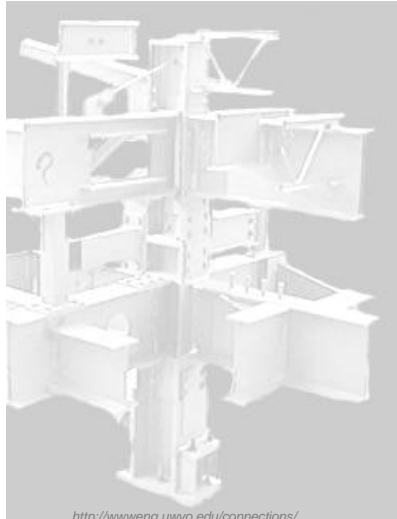

*AISC (Steel)
Sculpture
College Station, TX*

<http://www.eng.uwo.edu/connections/>
Introduction 12
Lecture 1

Elements of Architectural Structures
ARCH 614

S2005abn



*“Jamborie”
Philadelphia, PA
Daniel Barret*

Introduction 13
Lecture 1

Elements of Architectural Structures
ARCH 614

S2005abn

*Exploris Mobile
Heath Satow*



Introduction 14
Lecture 1

Elements of Architectural Structures
ARCH 614

S2005abn



*“Telamones”
Chicago, IL
Walter Arnold*

Introduction 15
Lecture 1

Elements of Architectural Structures
ARCH 614

S2005abn



“Free Ride Home” 1974
Kenneth Snelson

Introduction 16
Lecture 1

Elements of Architectural Structures
ARCH 614

S2005abn

“Zauber”
Laudenslager, Jeffery



Introduction 17
Lecture 1

Elements of Architectural Structures
ARCH 614

S2005abn



*Conference
Table*
Heath Satow

Introduction 18
Lecture 1

Elements of Architectural Structures
ARCH 614

S2005abn

Bar Stool
“Stainless Butterfly”
Daniel Barret



Introduction 19
Lecture 1

Elements of Architectural Structures
ARCH 614

S2005abn



Chair
Paul Freundt

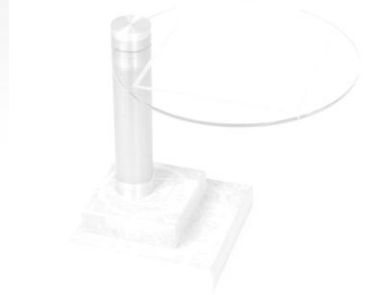
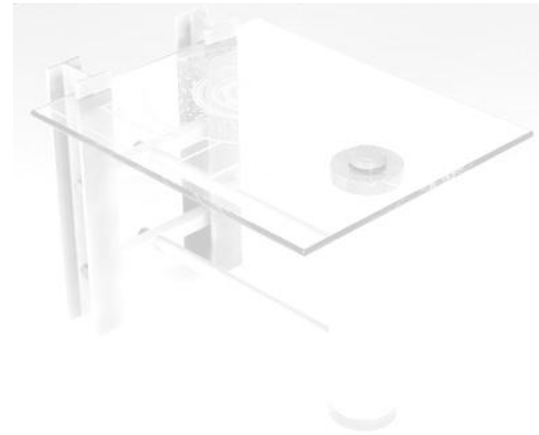

End Tables
Rameu-Richard

Introduction 20
Lecture 1

Elements of Architectural Structures
ARCH 614

S2005abn

Introduction 21
Lecture 1

Elements of Architectural Structures
ARCH 614

S2005abn



Steel House, Lubbock, TX
Robert Bruno

Introduction 22
Lecture 1

Elements of Architectural Structures
ARCH 614

S2005abn



Guggenheim Museum Bilbao
Frank Gehry (1997)

Introduction 23
Lecture 1

Elements of Architectural Structures
ARCH 614

S2005abn

*Tjibaou Cultural Center,
New Caledonia
Renzo Piano*



Photographer: John Gollings

Introduction 24
Lecture 1

Elements of Architectural Structures
ARCH 614

S2005abn



*Padre Pio Pilgrimage Church, Italy
Renzo Piano*

Photographer: Michel Denancé

Introduction 25
Lecture 1

Elements of Architectural Structures
ARCH 614

S2005abn



*Athens Olympic Stadium
and Velodrome
Santiago Calatrava (2004)*

Introduction 26
Lecture 1

Elements of Architectural Structures
ARCH 614

S2005abn

*Milwaukee Art Museum
Quadracci Pavilion (2001)
Santiago Calatrava*



Introduction 27
Lecture 1

Elements of Architectural Structures
ARCH 614

S2005abn

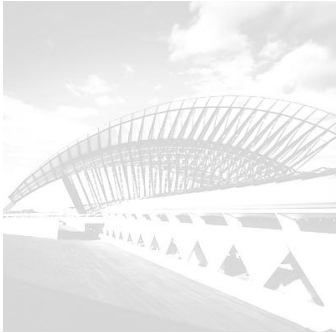

Airport Station, Lyon, France
Santiago Calatrava (1994)

Introduction 28
Lecture 1

Elements of Architectural Structures
ARCH 614

S2005abn



Centre Georges Pompidou, Paris
Piano and Rogers (1978)

Introduction 29
Lecture 1

Elements of Architectural Structures
ARCH 614

S2005abn



Hongkong Bank Building (1986)
Foster and Partners

Introduction 30
Lecture 1

Elements of Arch
ARCH 614

www.greatbuildings.com

Meyerson Symphony Center
Dallas, TX
Pei Cobb Freed & Partners



Introduction 31
Lecture 1

Elements of Architectural Structures
ARCH 614

S2005abn

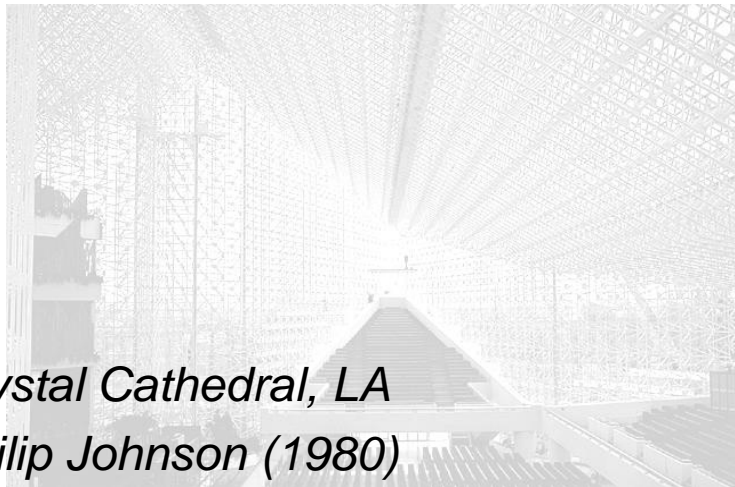

*Crystal Cathedral, LA
Philip Johnson (1980)*

Introduction 32
Lecture 1

Elements of Architectural Structures
ARCH 614

S2005abn



*Federal Reserve Bank
Minneapolis, MN
Gunnar Birkerts & Associates*

Introduction 33
Lecture 1

Elements of Architectural Structures
ARCH 614

S2005abn



www.greatbuildings.com

*Hysolar Research Building
Stuttgart, Germany
(1986 -87)
Gunter Behnisch*

Introduction 34
Lecture 1

Elements of Architectural Structures
ARCH 614

S2005abn



www.greatbuildings.com

*Notre Dame Cathedral
Paris, France
Maurice de Sully*

Introduction 35
Lecture 1

Elements of Architectural Structures
ARCH 614

S2005abn



Habitat 67, Montreal
Moshe Safdie (1967)

Introduction 36
Lecture 1

Elements of Architectural Structures
ARCH 614

S2005abn



Villa Savoye, Poissy, France
Le Corbusier (1929)

Introduction 37
Lecture 1

Elements of Architectural Structures
ARCH 614

S2005abn



Riola Parish Church
Riola, Italy
Alvar Aalto

Introduction 38
Lecture 1

Elements of Architectural Structures
ARCH 614

S2005abn



Kimball Museum, Fort Worth
Kahn (1972)

Introduction 39
Lecture 1

Elements of Architectural Structures
ARCH 614

S2005abn

Architectural Space and Form

- evolution traced to developments in structural engineering and material technology
 - stone & masonry
 - timber
 - concrete
 - cast iron, steel
 - tensile fabrics, pneumatic structures.....

Architectural Space and Form

- structure is a device for channeling loads that result from the use and/or presence of the building to the ground
 - span a roof
 - hold up a floor
 - cross a river
 - suspend a canopy

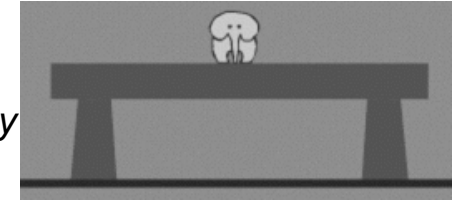

www.pbs.org/wgbh/buildingbig/

Introduction 40
Lecture 1

Elements of Architectural Structures
ARCH 614

S2005abn

Introduction 41
Lecture 1

Elements of Architectural Structures
ARCH 614

S2005abn

Stone + Masonry

- columns
- walls
- lintels
- arches



Introduction 42
Lecture 1

Elements of Architectural Structures
ARCH 614

S2005abn

Wood

- columns
- beams
- trusses



Introduction 43
Lecture 1

Elements of Architectural Structures
ARCH 614

S2005abn

Steel

- cast iron – wrought iron - steel
- cables
- columns
- beams
- trusses
- frames



Introduction 44
Lecture 1

<http://nisee.berkeley.edu/godden>
Elements of Architectural Structures
ARCH 614

S2005abn

Concrete

- columns
- beams
- slabs
- domes

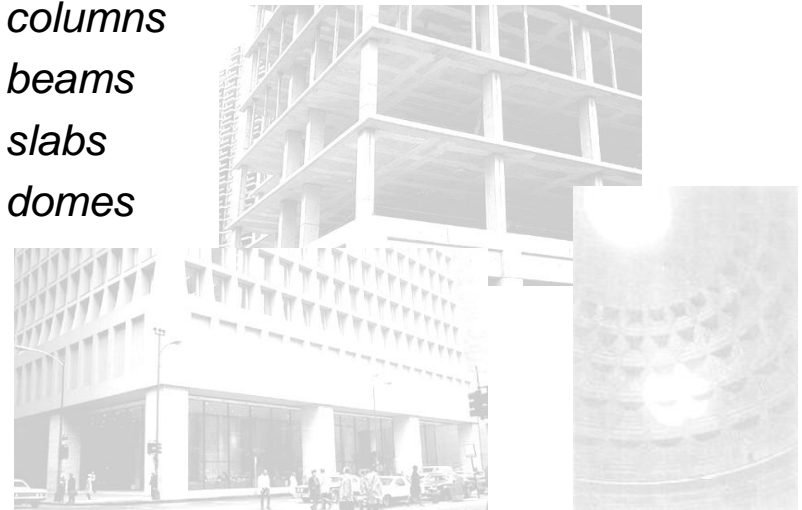

Introduction 45
Lecture 1

<http://nisee.berkeley.edu/godden>
Elements of Architectural Structures
ARCH 614

S2005abn

Structural Components

- bearing walls
- columns
- beams
- flat plates
- trusses
- arches
- shells
- cables

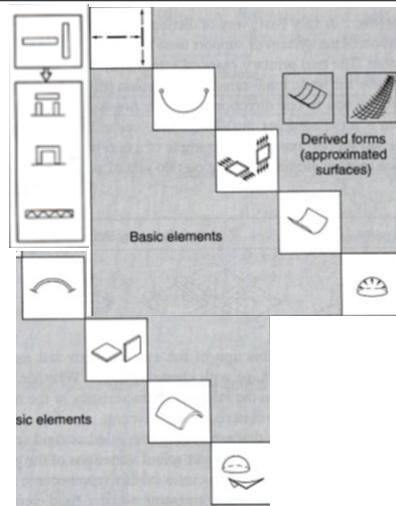

Introduction 46
Lecture 1

Elements of Architectural Structures
ARCH 614

S2005abn

Bearing Walls

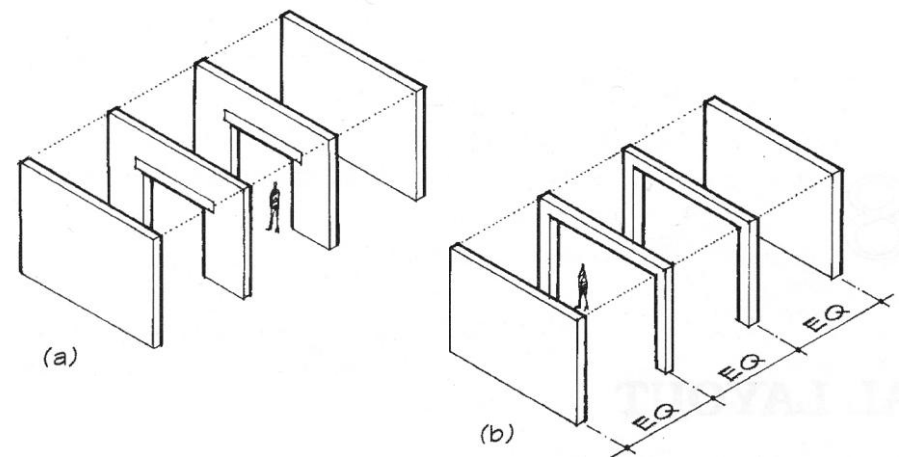

Introduction 47
Lecture 1

Elements of Architectural Structures
ARCH 614

S2005abn

Bearing Walls

- behavior as “deep beams”

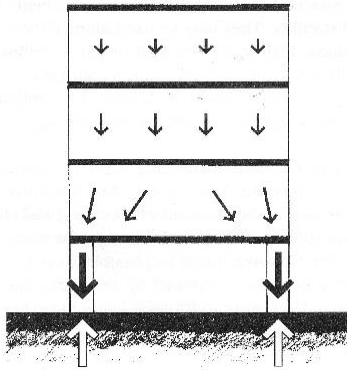

Introduction 48
Lecture 1

Elements of Architectural Structures
ARCH 614

S2005abn

Beams & Plates

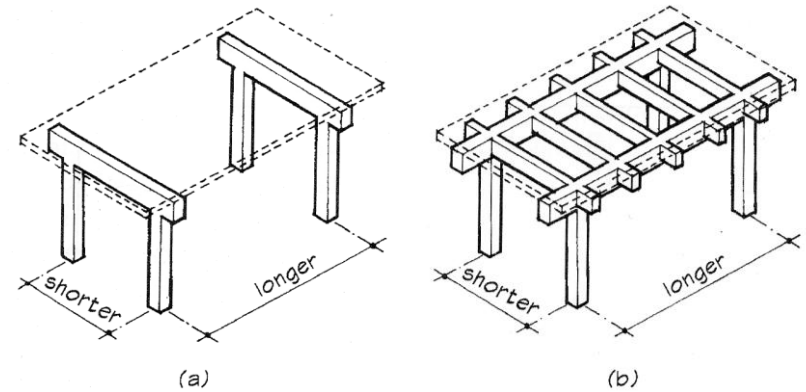

Introduction 49
Lecture 1

Elements of Architectural Structures
ARCH 614

S2005abn

Beams & Plates

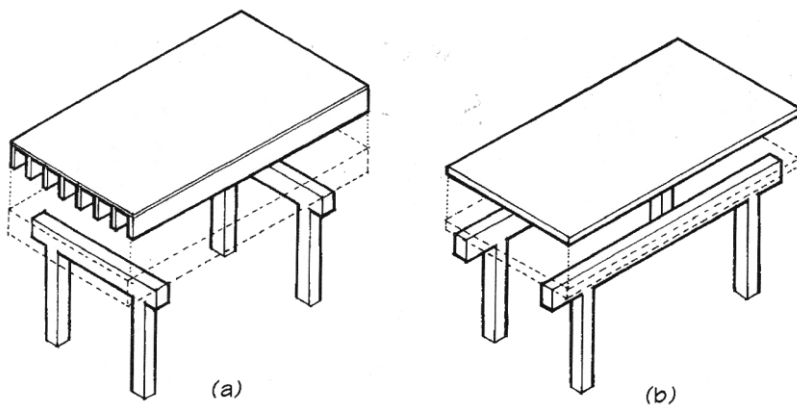

Introduction 50
Lecture 1

Elements of Architectural Structures
ARCH 614

S2005abn

Building Framing

- Components or Assemblages

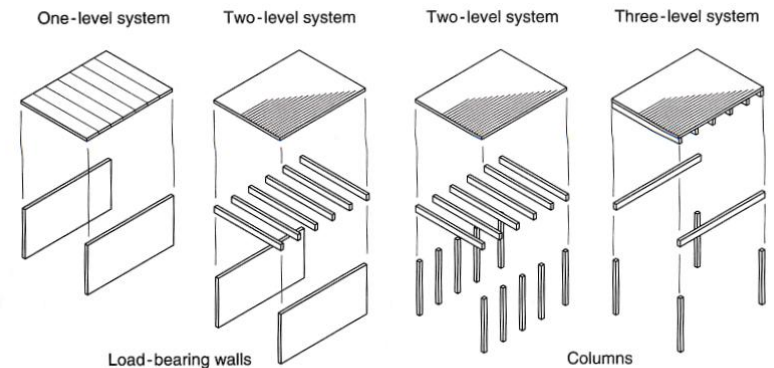

(a) Common types of horizontal spanning systems (one, two, and three level systems) used in relation to different types of load-bearing wall and columnar vertical support systems.

Introduction 51
Lecture 1

Elements of Architectural Structures
ARCH 614

S2005abn

Building Framing

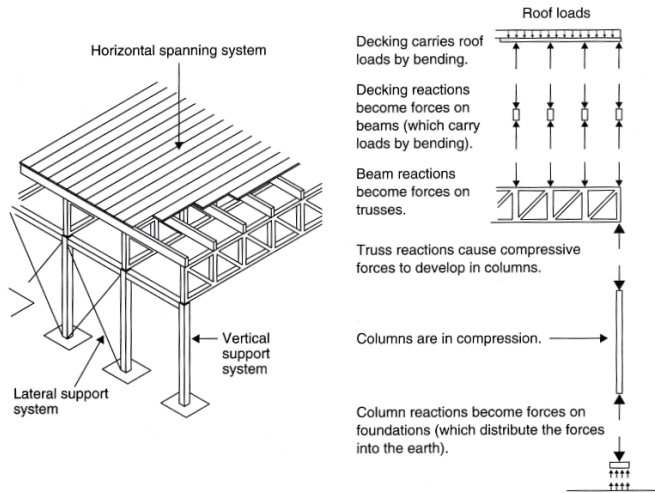

Introduction 52
Lecture 1

Elements of Architectural Structures
ARCH 614

S2005abn

System Selection

- evaluation of alternatives

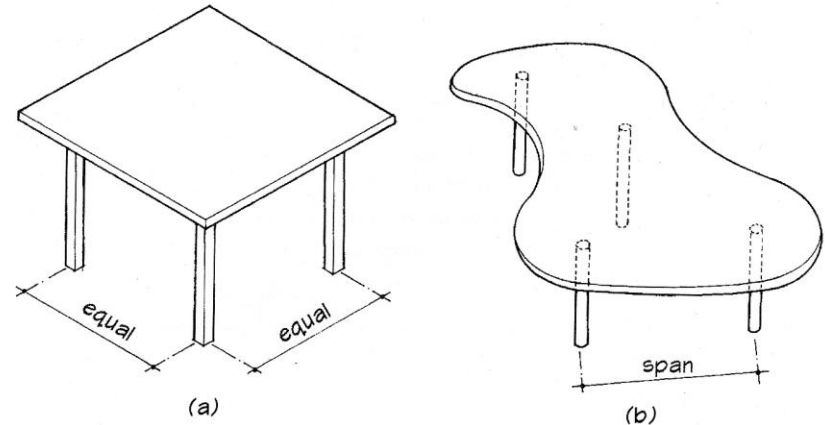

Introduction 53
Lecture 1

Elements of Architectural Structures
ARCH 614

S2005abn

DESIGN CRITERIA	Light-frame timber	Heavy-frame timber	Masonry bearing wall	Steel frame (hinge connections)	Steel frame (rigid connections)	Steel open-web joists	Steel space frame	Steel decking	Site-cast concrete: one-way slab	Site-cast concrete: two-way plate	Site-cast concrete: two-way slab	Site-cast concrete: one-way joists	Site-cast concrete: waffle slab	Precast concrete: solid slab	Precast concrete: hollow-core slab	Precast concrete: single tee	Precast concrete: double tee	RATIONALE
Exposed, fire-resistive construction																		Inherently fire-resistive construction
Irregular building form																		Simple, site-fabricated systems
Irregular column placement																		Systems without beams in roof or floors
Minimize floor thickness																		Precast-concrete systems without ribs
Allow for future renovations																		Short-span, one-way, easily modified
Permit construction in poor weather																		Quickly erected; avoid site-cast concrete
Minimize off-site fabrication time																		Easily formed or built on site
Minimize on-site erection time																		Highly prefabricated; modular components
Minimize low-rise construction time																		Lightweight, easily formed or prefabricated
Minimize medium-rise construction time																		Precast, site-cast concrete; steel frames
Minimize high-rise construction time																		Strong; prefabricated; lightweight
Minimize shear walls or diagonal bracing																		Capable of forming rigid joints
Minimize dead load on foundations																		Lightweight, short-span systems
Minimize damage due to foundation settlement																		Systems without rigid joints
Minimize the number of separate trades on job																		Multipurpose components
Provide concealed space for mech. services																		Systems that inherently provide voids
Minimize the number of supports																		Two-way, long-span systems
Long spans																		Long-span systems

Introduction 54
Lecture 1

Elements of Architectural Structures
ARCH 614

S2005abn

Structural Math

- quantify environmental loads
 - how big is it?
- evaluate geometry and angles
 - where is it?
 - what is the scale?
 - what is the size in a particular direction?
- quantify what happens in the structure
 - how big are the internal forces?
 - how big should the beam be?

Math 4
Lecture 2

Elements of Architectural Structures
ARCH 614

S2005abn

On-line Practice

- Vista / Study Aids

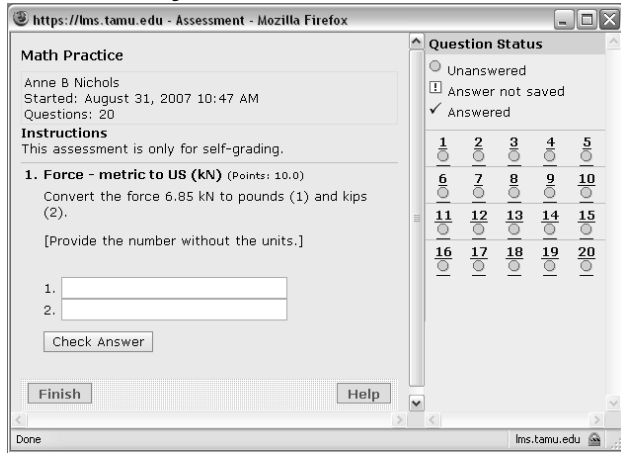

Introduction 61
Lecture 1

Elements of Architectural Structures
ARCH 614

S2008abn

Geometry

- shapes

- rectangle
- triangle
- right triangle
- equilateral triangle
- rhomboid
- parallelogram



Math 9
Lecture 2

Elements of Architectural Structures
ARCH 614

S2005abn

Geometry

- angles

- right = 90°
- acute $< 90^\circ$
- obtuse $> 90^\circ$
- $\pi = 180^\circ$

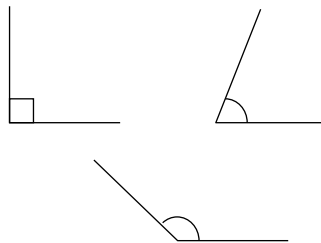

- triangles

- area
- hypotenuse
- total of angles = 180°

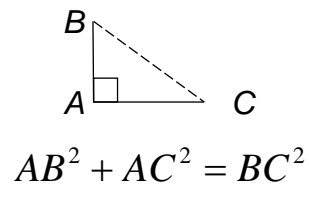

Math 10
Lecture 2

Elements of Architectural Structures
ARCH 614

S2005abn

Geometry

- lines and relation to angles

- parallel lines can't intersect
- perpendicular lines cross at 90°
- intersection of two lines is a point
- opposite angles are equal when two lines cross

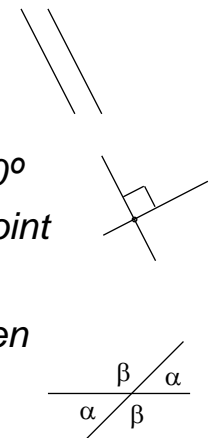

Math 11
Lecture 2

Elements of Architectural Structures
ARCH 614

S2005abn

Geometry

– intersection of a line with parallel lines results in identical angles

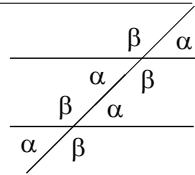

– two lines intersect in the same way, the angles are identical

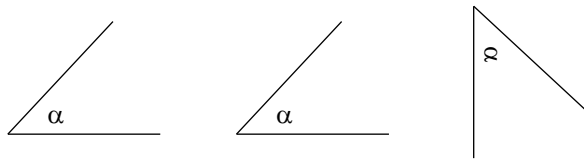

Math 12
Lecture 2

Elements of Architectural Structures
ARCH 614

S2005abn

Geometry

– sides of two angles are parallel and intersect opposite way, the angles are supplementary - the sum is 180°



– two angles that sum to 90° are said to be complimentary

$$\beta + \gamma = 90^\circ$$

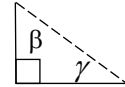

Math 13
Lecture 2

Elements of Architectural Structures
ARCH 614

S2005abn

Geometry

– sides of two angles bisect a right angle (90°), the angles are complimentary

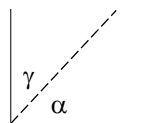

$$\alpha + \gamma = 90^\circ$$

– right angle bisects a straight line, remaining angles are complimentary

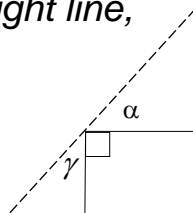

Math 14
Lecture 2

Elements of Architectural Structures
ARCH 614

S2005abn

Geometry

– similar triangles have proportional sides

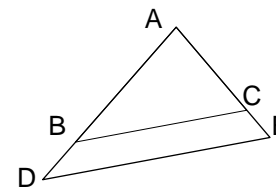

$$\frac{AB}{AD} = \frac{AC}{AE} = \frac{BC}{DE}$$

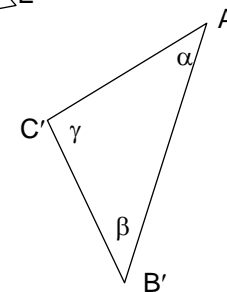
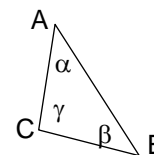

$$\frac{AB}{A'B'} = \frac{AC}{A'C'} = \frac{BC}{B'C'}$$

Math 15
Lecture 2

Elements of Architectural Structures
ARCH 614

S2005abn

Trigonometry

- for right triangles

$$\sin = \frac{\text{opposite side}}{\text{hypotenuse}} = \sin \alpha = \frac{AB}{CB}$$

$$\cos = \frac{\text{adjacent side}}{\text{hypotenuse}} = \cos \alpha = \frac{AC}{CB}$$

$$\tan = \frac{\text{opposite side}}{\text{adjacent side}} = \tan \alpha = \frac{AB}{AC}$$

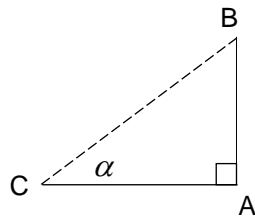

SOHCAHTOA

Math 16
Lecture 2

Elements of Architectural Structures
ARCH 614

S2005abn

Trigonometry

- cartesian coordinate system

- origin at 0,0
- coordinates in (x,y) pairs
- x & y have signs

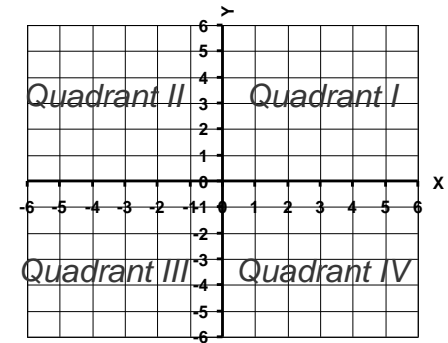

Math 17
Lecture 2

Elements of Architectural Structures
ARCH 614

S2005abn

Trigonometry

- for angles starting at positive x

- sin is y side
- cos is x side

$\sin < 0$ for 180-360°
 $\cos < 0$ for 90-270°
 $\tan < 0$ for 90-180°
 $\tan < 0$ for 270-360°

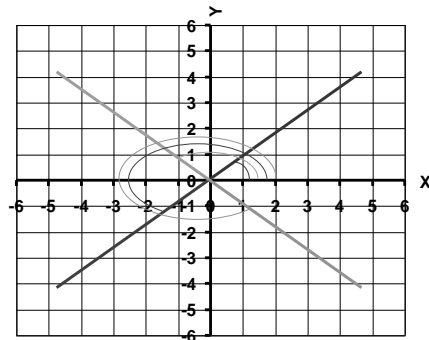

Math 18
Lecture 2

Elements of Architectural Structures
ARCH 614

S2005abn

Trigonometry

- for all triangles

- sides A, B & C are opposite angles α , β & γ

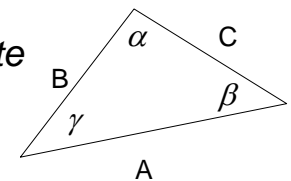

- LAW of SINES

$$\frac{\sin \alpha}{A} = \frac{\sin \beta}{B} = \frac{\sin \gamma}{C}$$

- LAW of COSINES

$$A^2 = B^2 + C^2 - 2BC \cos \alpha$$

Math 19
Lecture 2

Elements of Architectural Structures
ARCH 614

S2005abn

Algebra

- equations (something = something)
- constants
 - real numbers or shown with $a, b, c...$
- unknown terms, variables
 - names like R, F, x, y
- linear equations
 - unknown terms have no exponents
- simultaneous equations
 - variable set satisfies all equations

Math 20
Lecture 2

Elements of Architectural Structures
ARCH 614

S2005abn

Algebra

- solving one equation
 - only works with one variable
 - ex:
 - add to both sides $2x - 1 = 0$
 $2x - 1 + 1 = 0 + 1$
 $2x = 1$
 - divide both sides $\frac{2x}{2} = \frac{1}{2}$
 - get x by itself on a side $x = \frac{1}{2}$

Math 21
Lecture 2

Elements of Architectural Structures
ARCH 614

S2005abn

Algebra

- solving one equations
 - only works with one variable
 - ex: $2x - 1 = 4x + 5$
 - subtract from both sides
 $2x - 1 - 2x = 4x + 5 - 2x$
 - subtract from both sides
 $-1 - 5 = 2x + 5 - 5$
 - divide both sides $\frac{-6}{2} = \frac{-3 \cdot 2}{2} = \frac{2x}{2}$
 - get x by itself on a side
 $x = -3$

Math 22
Lecture 2

Elements of Architectural Structures
ARCH 614

S2005abn

Algebra

- solving two equation
 - only works with two variables
 - ex: $2x + 3y = 8$
 - look for term similarity $12x - 3y = 6$
 - can we add or subtract to eliminate one term?
 - add $2x + 3y + 12x - 3y = 8 + 6$
 $14x = 14$
 - get x by itself on a side $\frac{14x}{14} = \frac{14}{14} = x = 1$

Math 23
Lecture 2

Elements of Architectural Structures
ARCH 614

S2005abn

Physics for Structures

- *measures*
- *vectors*
- *motion of particles*
- *center of mass*
- *equilibrium of bodies*
- *gravitation*
- *fluid mechanics*
- *temperature*

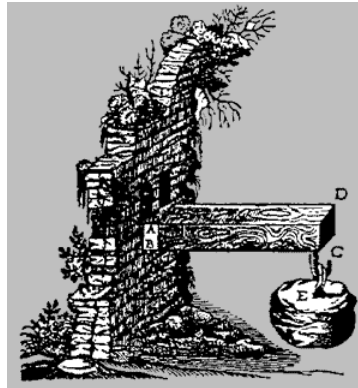

Galileo Galilei

Math 24
Lecture 2

Elements of Architectural Structures
ARCH 614

S2005abn

Physics for Structures

- *measures*
 - *US customary & SI*

Units	US	SI
Length	in, ft, mi	mm, cm, m
Volume	gallon	liter
Mass	lb mass	g, kg
Force	lb force	N, kN
Temperature	F	C

Math 25
Lecture 2

Elements of Architectural Structures
ARCH 614

S2005abn

Physics for Structures

- *scalars – any quantity*
- *vectors - quantities with direction*
 - *like displacements*
 - *summation results in the “straight line path” from start to end*
 - *normal vector is perpendicular to something*

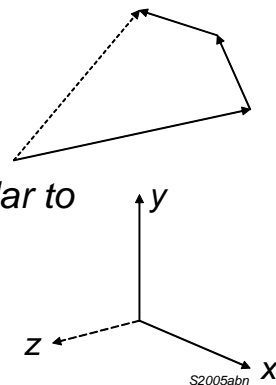

Math 26
Lecture 2

Elements of Architectural Structures
ARCH 614

S2005abn

Physics for Structures

- *motion of particles*
 - *displacement*
 - *velocity*
 - *acceleration*
 - *rotation*
 - *cause by forces*



<http://www.physics.umd.edu/>

Math 27
Lecture 2

Elements of Architectural Structures
ARCH 614

S2005abn

Physics for Structures

- gravity
 - acceleration of mass toward the earth
 - weight or force due to gravity
- center of gravity
 - location of mass doesn't change with motion



Math 28
Lecture 2

Elements of Architectural Structures
ARCH 614

S2005abn

Physics for Structures

- equilibrium of particles – no movement

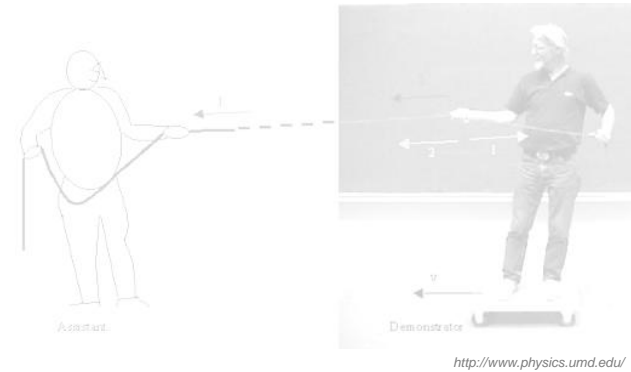

Math 29
Lecture 2

Elements of Architectural Structures
ARCH 614

S2005abn

Physics for Structures

- fluid mechanics
 - weight of water or fluid causes pressure on any surface it interacts with
 - pressure is force over an area
 - air pressure causes forces
 - water pressure gets greater as it gets deeper

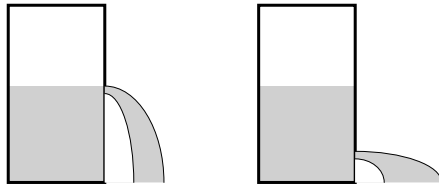

Math 30
Lecture 2

Elements of Architectural Structures
ARCH 614

S2005abn

Physics for Structures

- temperature
 - atoms respond to heat (physical chemistry)
 - with heat solid goes to liquid goes to gas
 - excited electrons move apart
 - movement is linear
 - base 0 or freezing at the temperature water freezes at

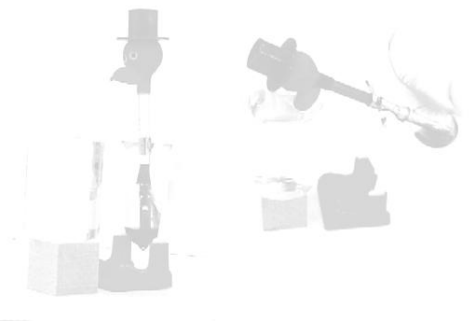

Math 31
Lecture 2

Elements of Architectural Structures
ARCH 614

S2005abn