

*ELEMENTS OF ARCHITECTURAL STRUCTURES:
FORM, BEHAVIOR, AND DESIGN*

ARCH 614

DR. ANNE NICHOLS

SPRING 2013

lecture
nine

*beams:
bending and shear stress*

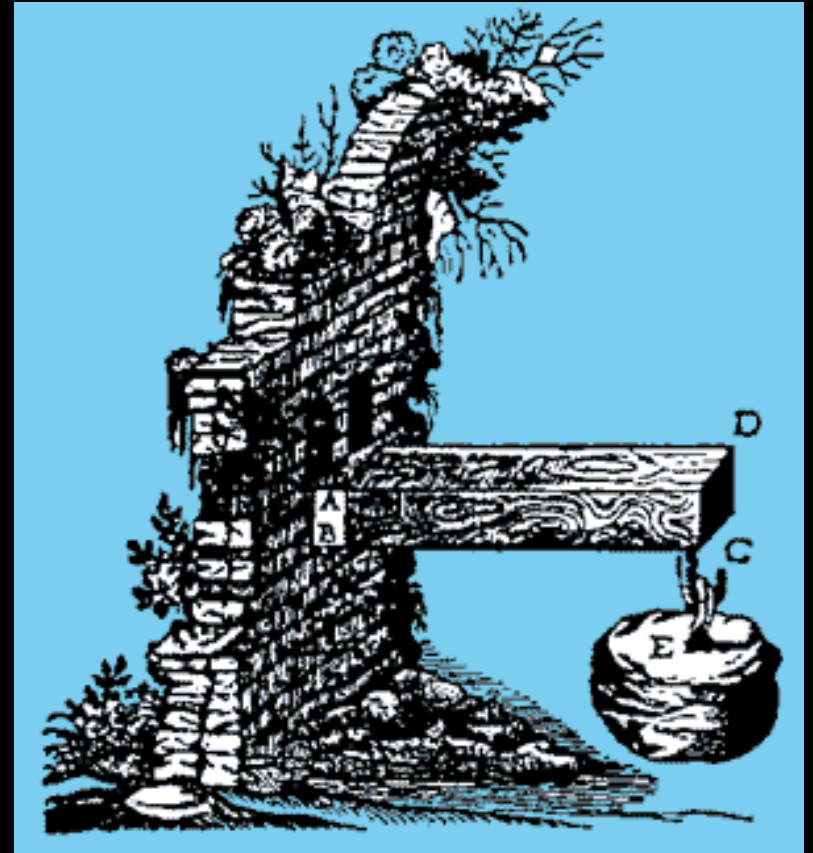

Beam Bending

- Galileo
 - relationship between stress and depth²
- can see
 - top squishing
 - bottom stretching

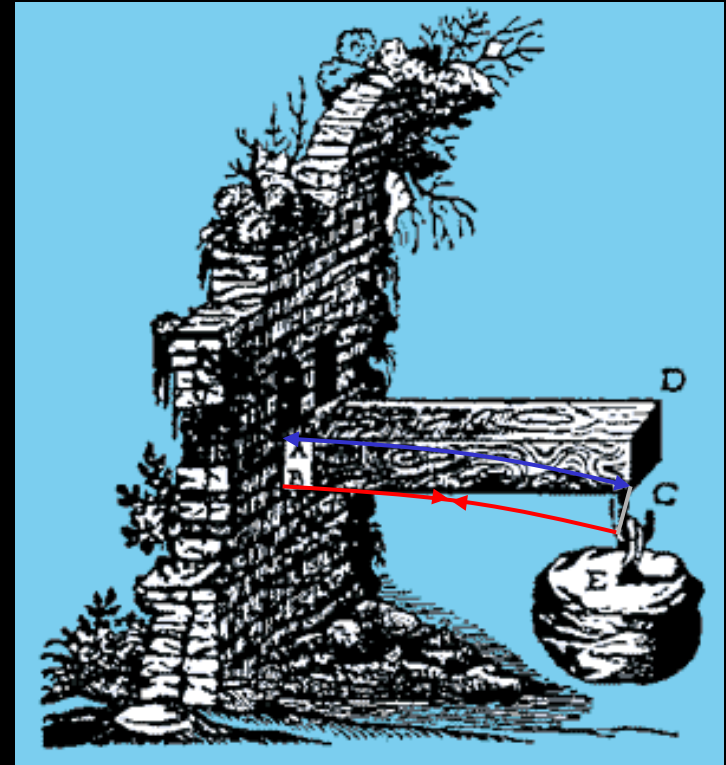

- what are the stress across the section?

Pure Bending

- *bending only*
- *no shear*
- *axial normal stresses from bending can be found in*
 - *homogeneous materials*
 - *plane of symmetry*
 - *follow Hooke's law*

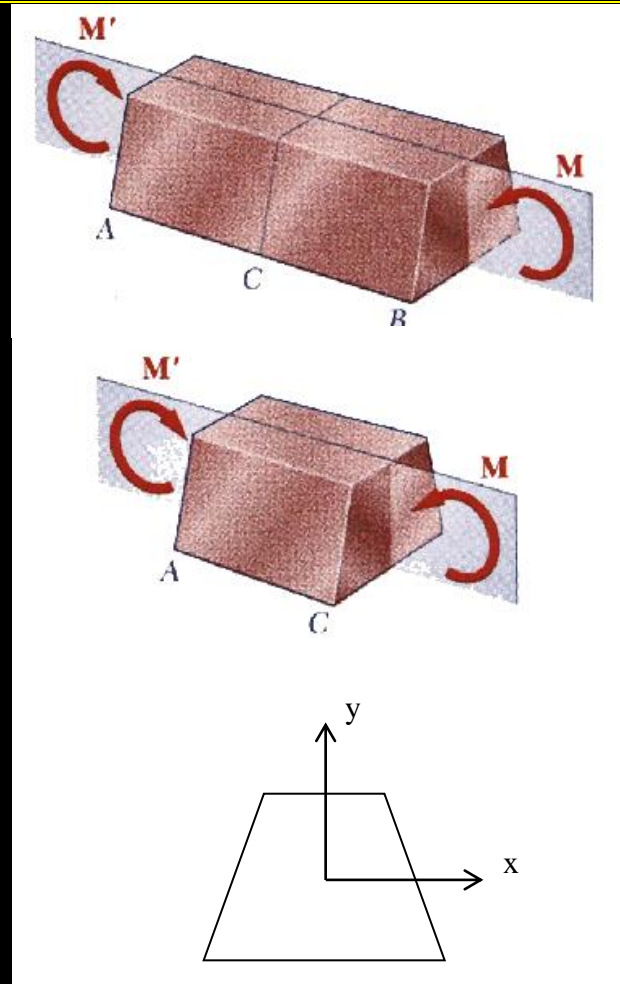

Bending Moments

- *sign convention:*

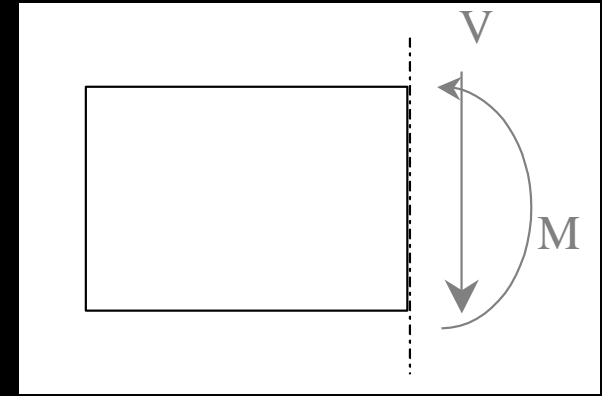
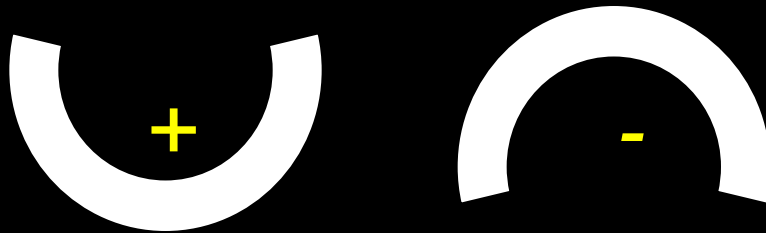

- *size of maximum internal moment will govern our design of the section*

Normal Stresses

- *geometric fit*
 - *plane sections remain plane*
 - *stress varies linearly*

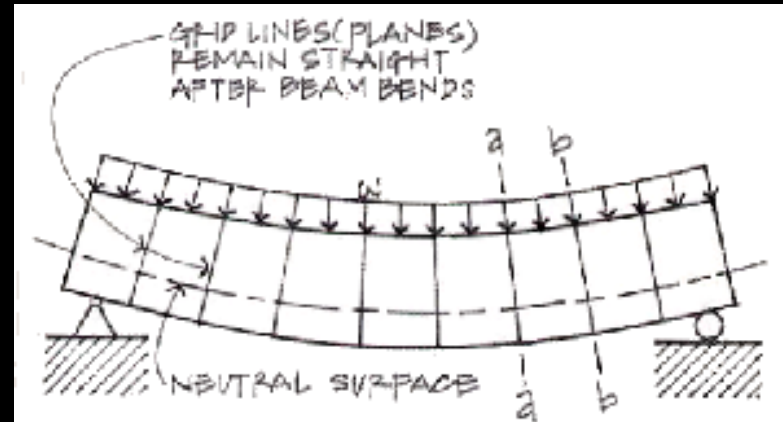

Figure 8.5(b) Beam bending under load.

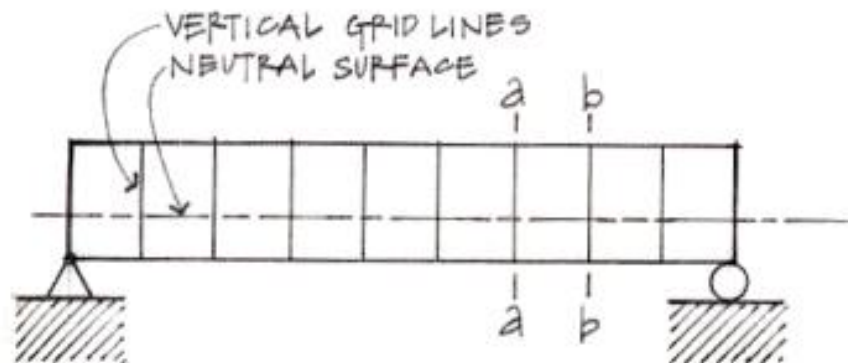
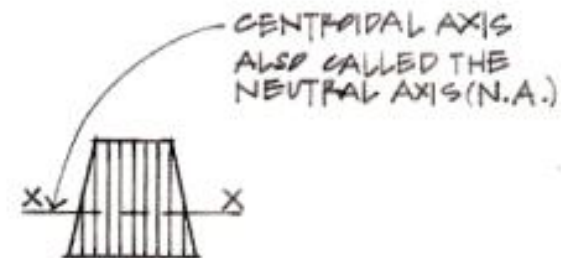

Figure 8.5(a) Beam elevation before loading.



Beam cross section.

Neutral Axis

- *stresses vary linearly*
- *zero stress occurs at the centroid*
- *neutral axis is line of centroids (n.a.)*

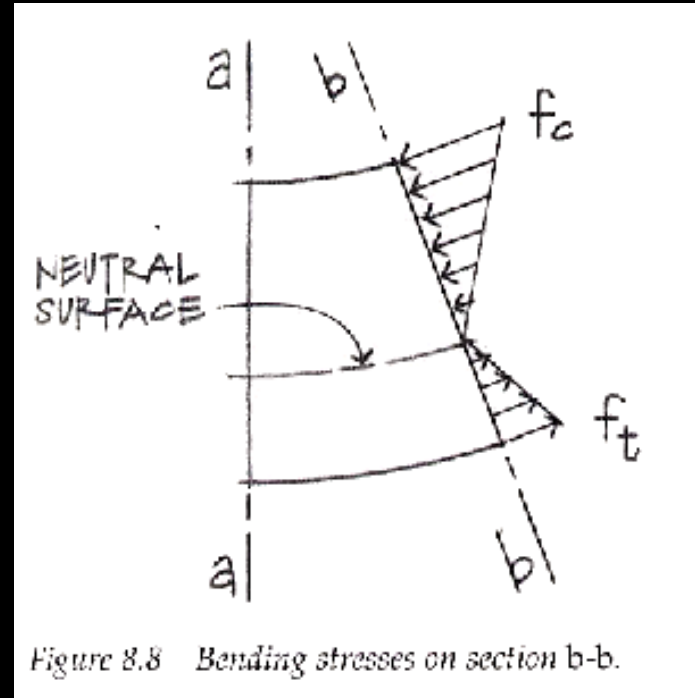

Derivation of Stress

- zero stress at n.a.

$$f = E\varepsilon = \frac{Ey}{R}$$

$$f_{\max} = \frac{Ec}{R}$$

$$f = \frac{y}{c} f_{\max}$$

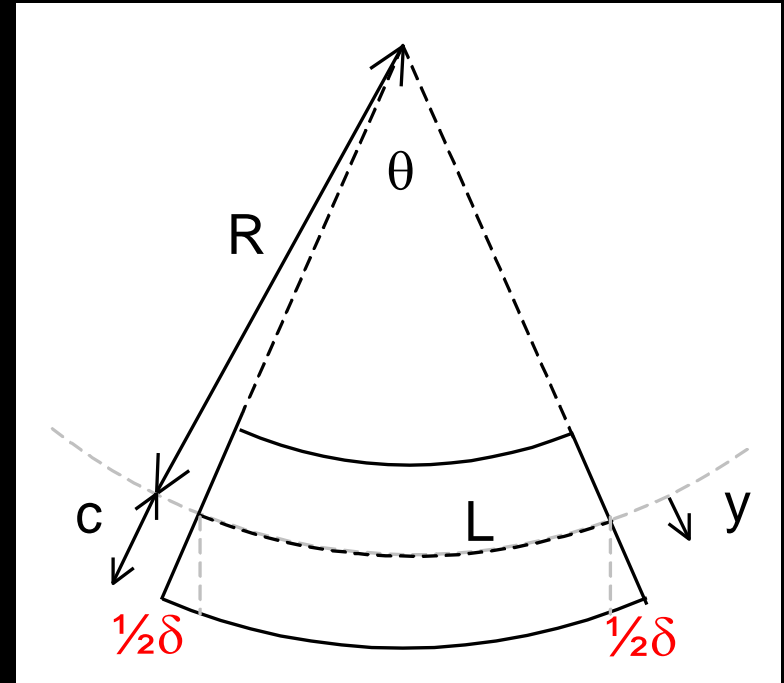

Bending Moment

- resultant moment from stresses = bending moment!

$$M = \sum f y \Delta A$$

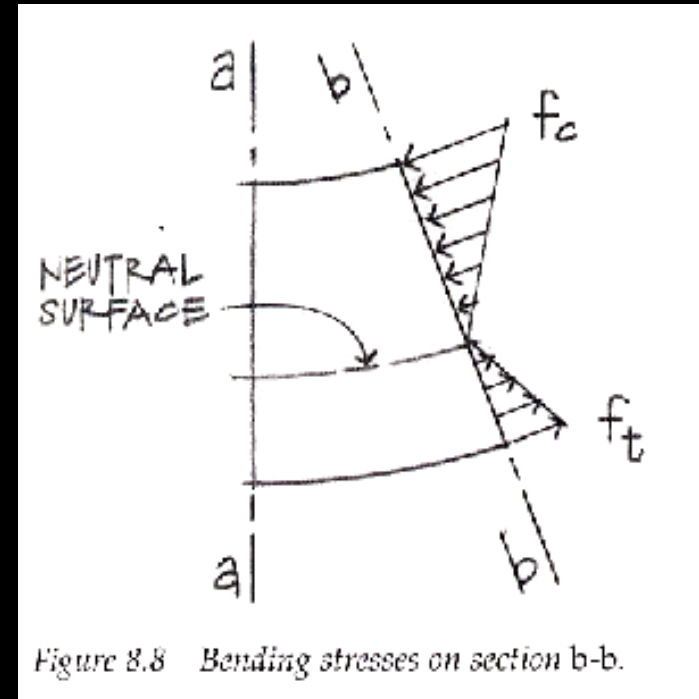
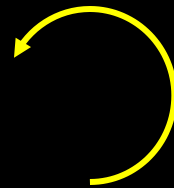

Figure 8.8 Bending stresses on section b-b.

$$= \sum \frac{y f_{max}}{c} y \Delta A = \frac{f_{max}}{c} \underline{\sum y^2 \Delta A} = \frac{f_{max}}{c} I = f_{max} S$$

Bending Stress Relations

$$\frac{1}{R} = \frac{M}{EI}$$

curvature

$$f_b = \frac{My}{I}$$

general bending stress

$$S = \frac{I}{c}$$

section modulus

$$f_b = \frac{M}{S}$$

maximum bending stress

$$S_{required} \geq \frac{M}{F_b}$$

required section modulus for design

Transverse Loading and Shear

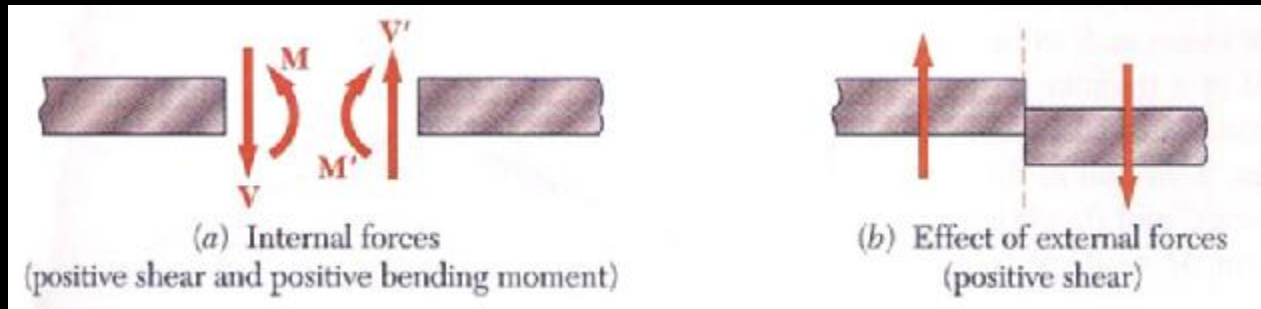

- *perpendicular loading*
- *internal shear*
- *along with bending moment*

Bending vs. Shear in Design

- *bending stresses dominate*
- *shear stresses exist horizontally with shear*
- *no shear stresses with pure bending*

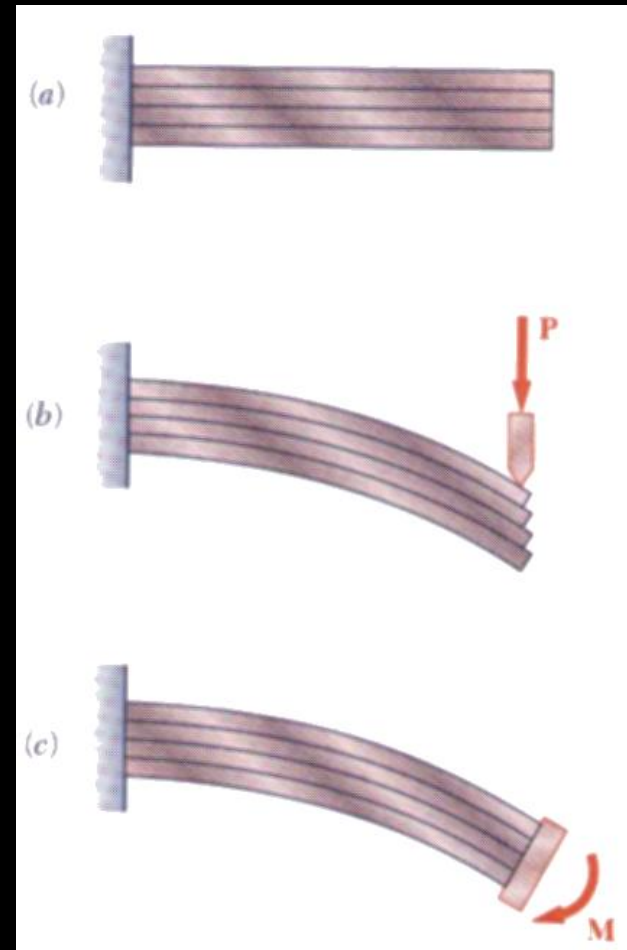

Shear Stresses

- *horizontal & vertical*

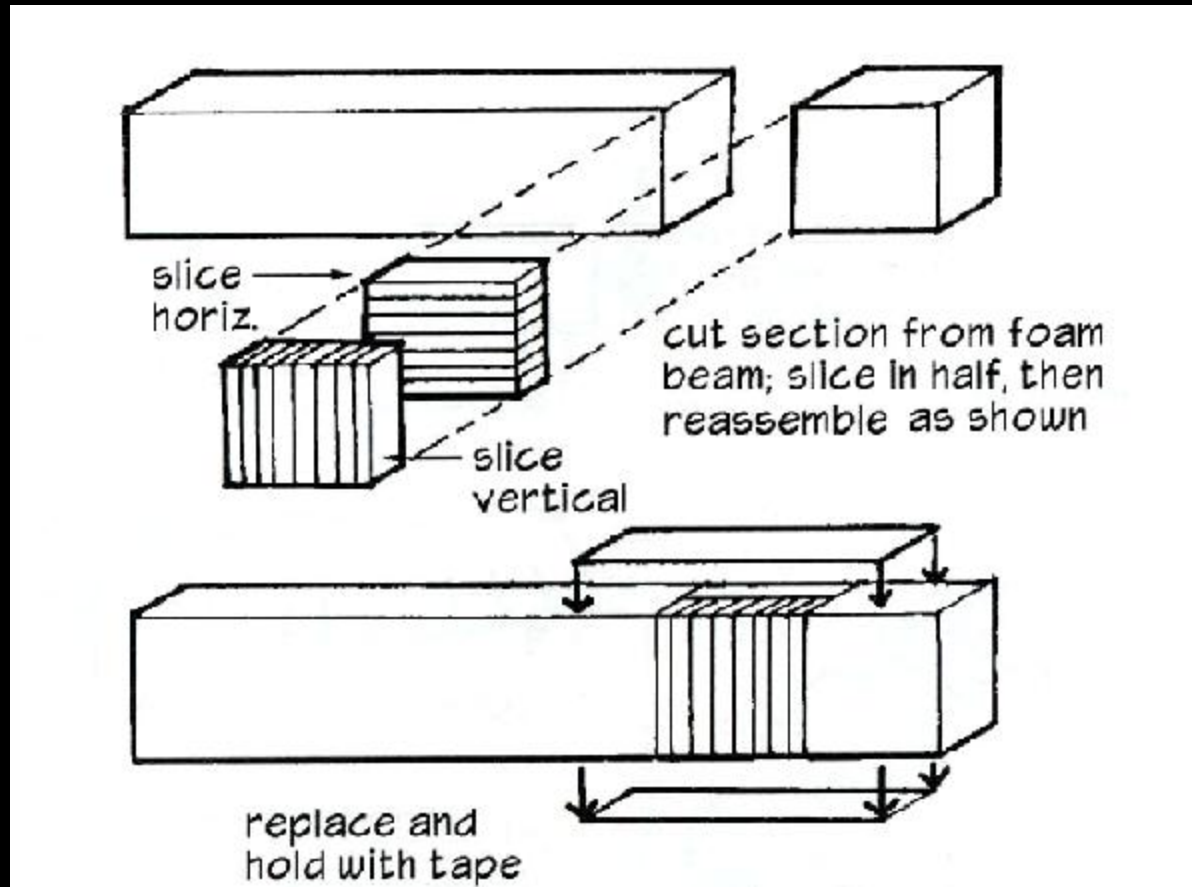

Shear Stresses

- *horizontal & vertical*

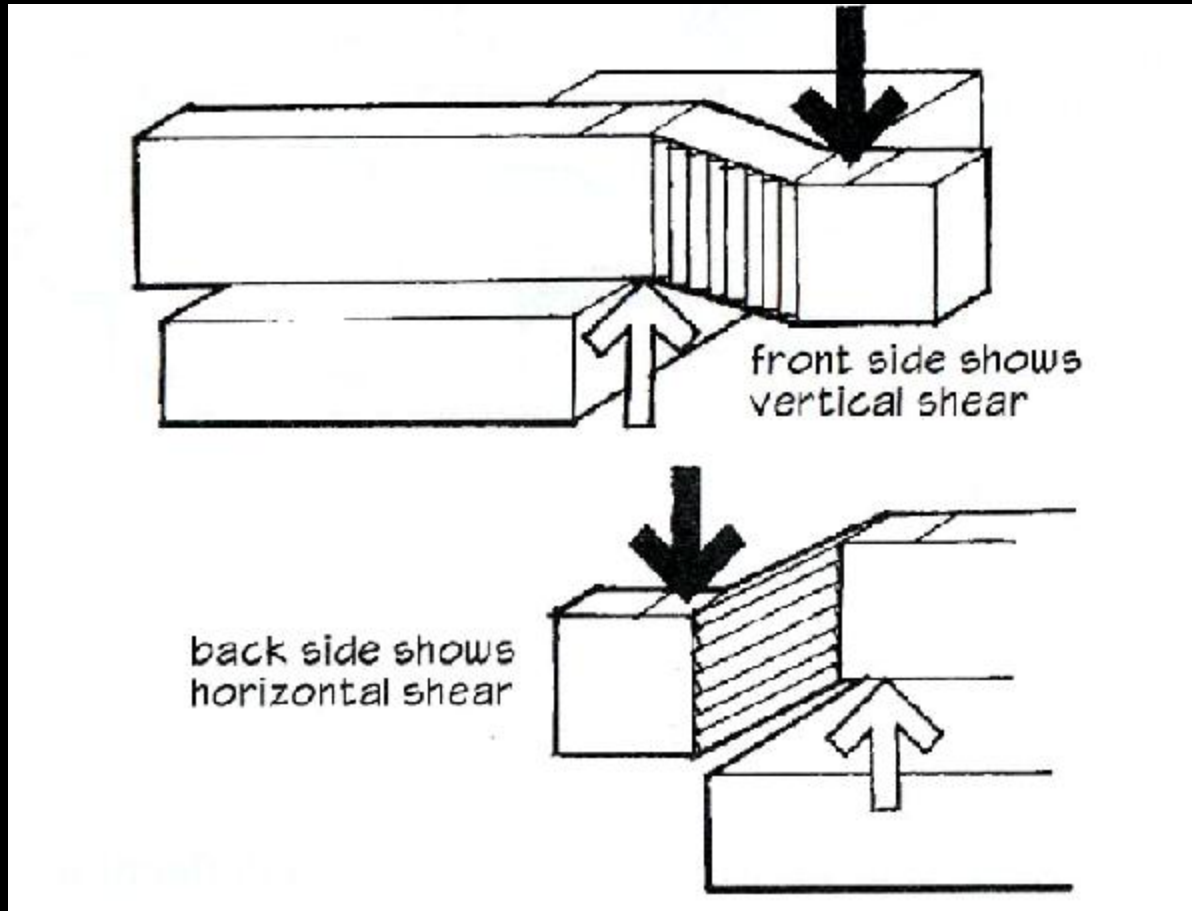

Beam Stresses

- *horizontal with bending*

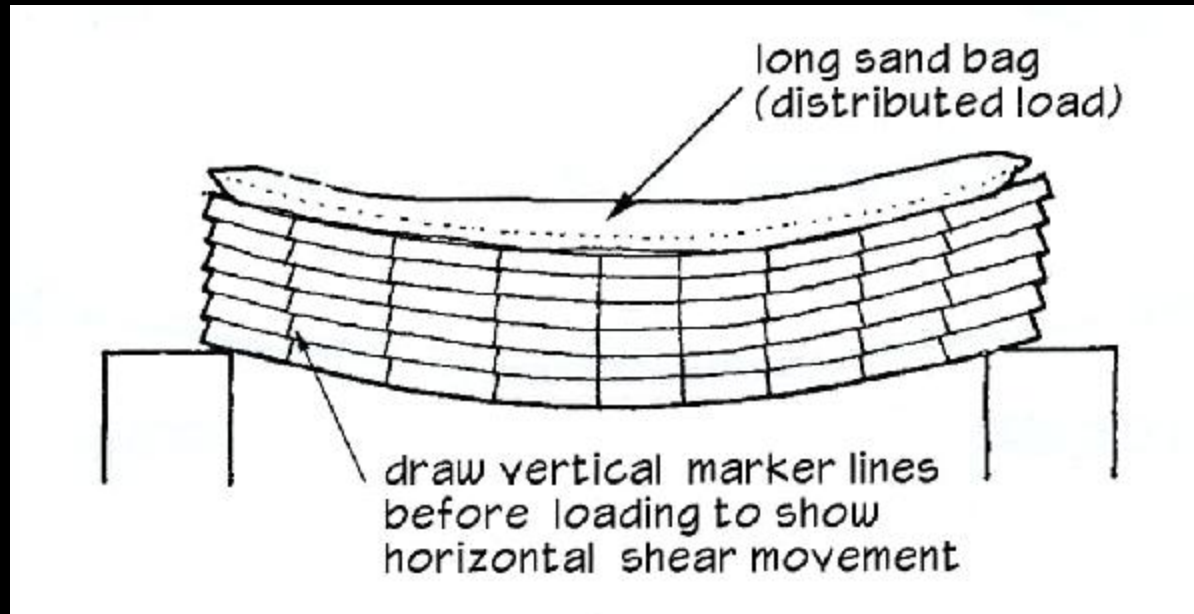

Equilibrium

- horizontal force V needed

$$V_{longitudinal} = \frac{V_T Q}{I} \Delta x$$

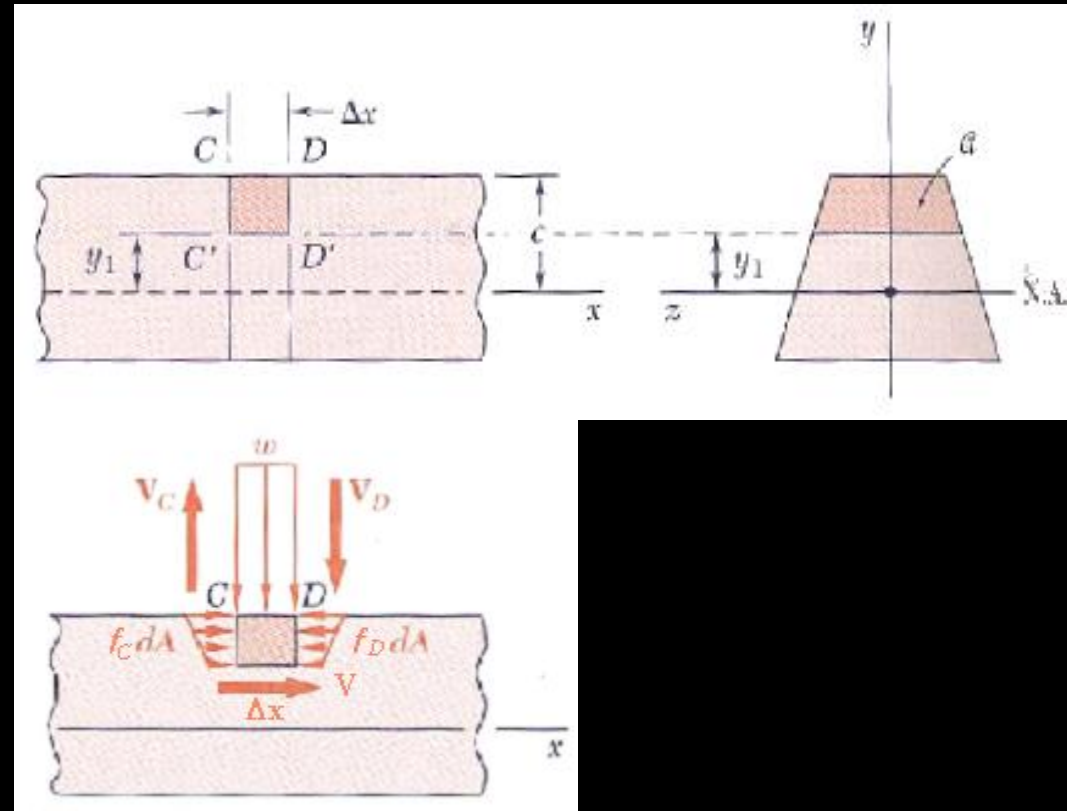

- Q is a moment area

Moment of Area

- Q is a moment area with respect to the n.a. of area above or below the horizontal

- Q_{max} at $y=0$
(neutral axis)

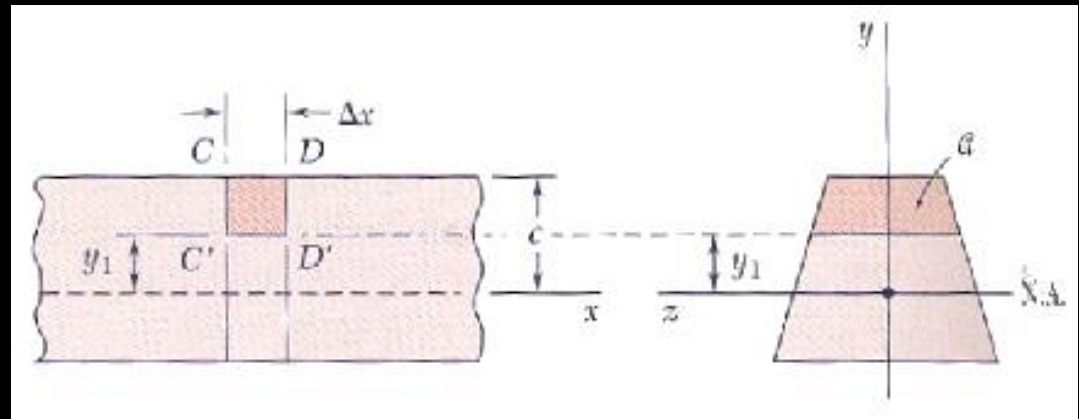

- q is shear flow:

$$q = \frac{V_{longitudinal}}{\Delta x} = \frac{V_T Q}{I}$$

Shearing Stresses

$$f_v = \frac{V}{\Delta A} = \frac{V}{b \cdot \Delta x}$$

$$f_{v-ave} = \frac{VQ}{Ib}$$

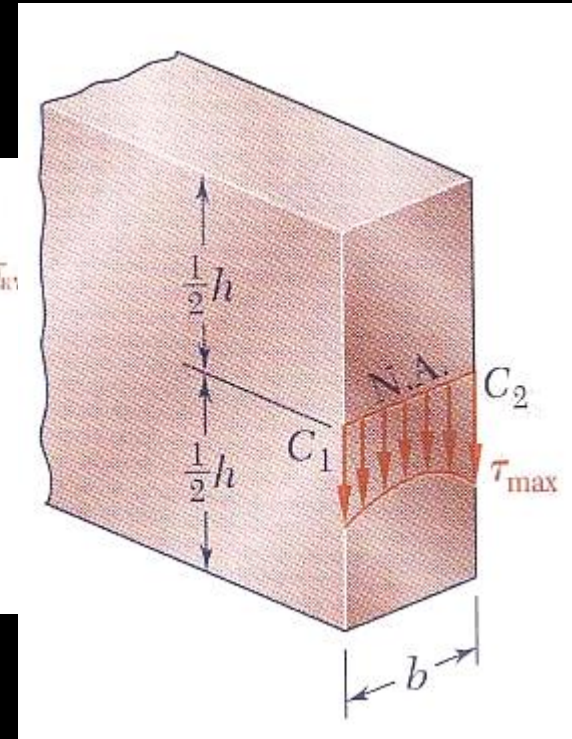
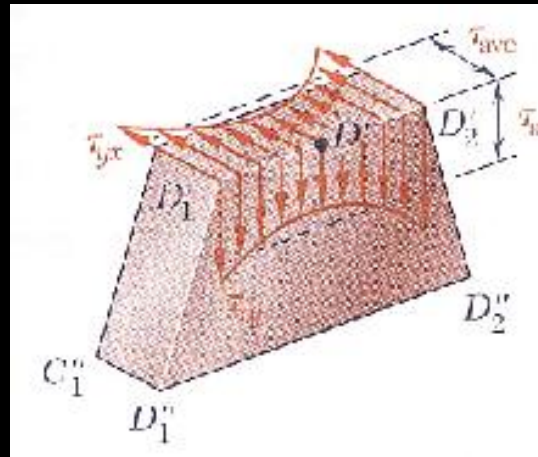

- $f_{v-ave} = 0$ on the top/bottom
- b min may not be with Q max
- with $h/4 \geq b$, $f_{v-max} \leq 1.008 f_{v-ave}$

Rectangular Sections

$$I = \frac{bh^3}{12} \quad Q = A\bar{y} = bh^2/8$$

$$f_v = \frac{VQ}{Ib} = \frac{3V}{2A}$$

- f_{v-max} occurs at n.a.

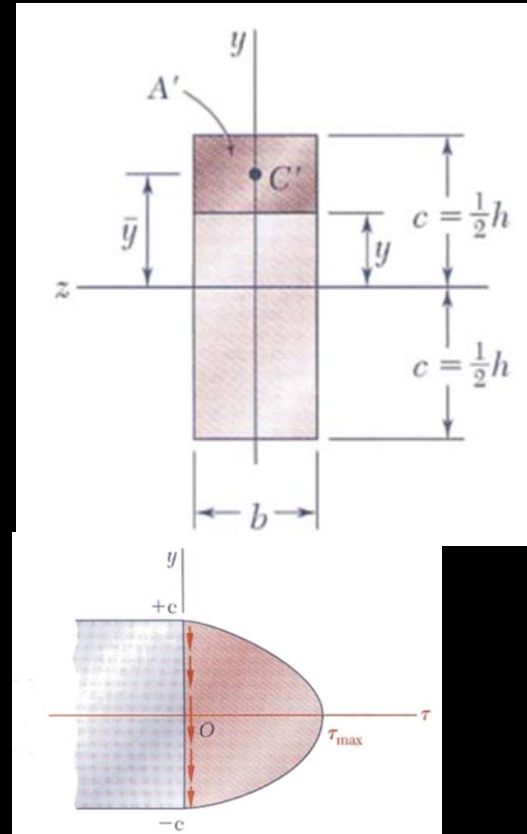

Steel Beam Webs

- *W and S sections*
 - *b varies*

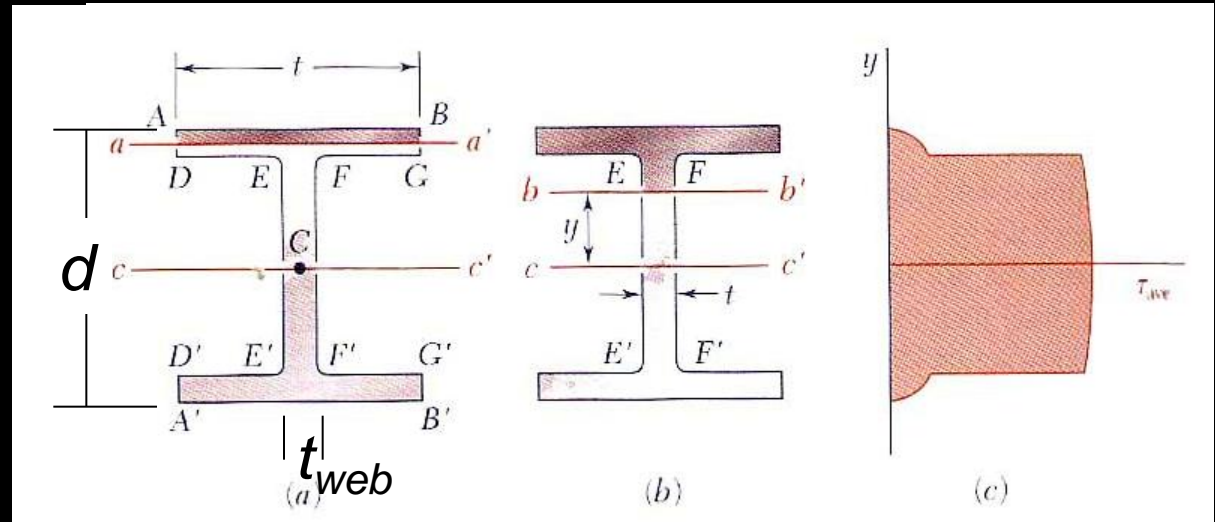

- *stress in flange negligible*
- *presume constant stress in web*

$$f_{v-\max} = \frac{3V}{2A} \approx \frac{V}{A_{web}}$$

Shear Flow

- loads applied in plane of symmetry
- cut made perpendicular

$$q = \frac{VQ}{I}$$

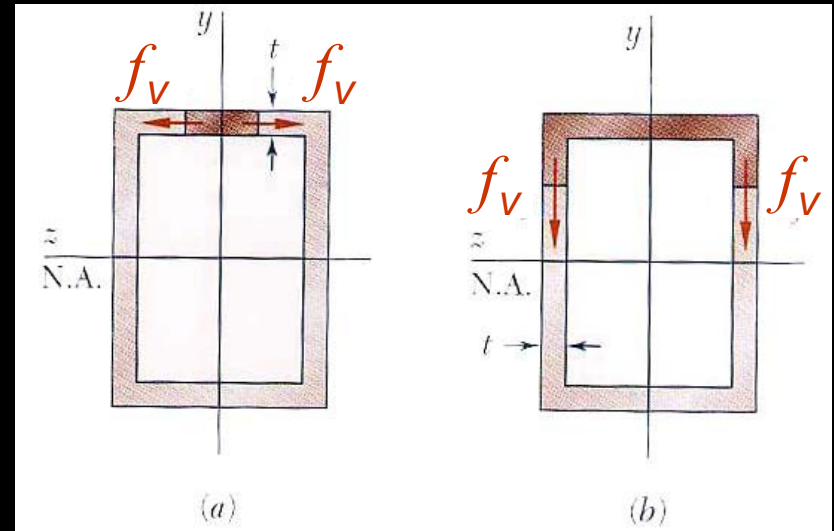
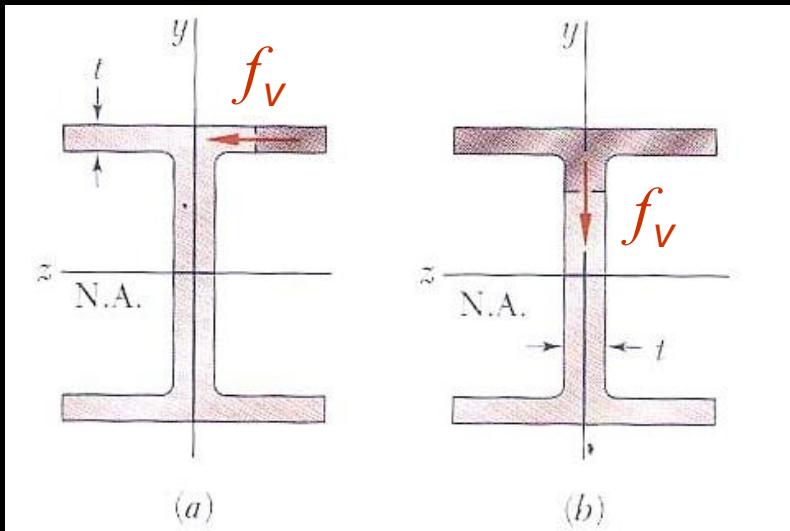

Shear Flow Quantity

- sketch from Q

$$q = \frac{VQ}{I}$$

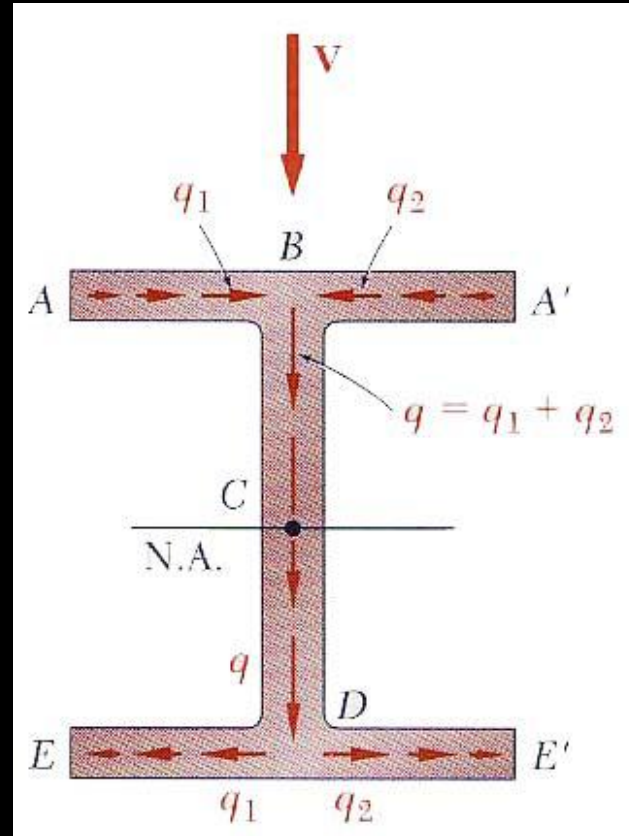

Connectors Resisting Shear

- plates with
 - nails
 - rivets
 - bolts
- splices

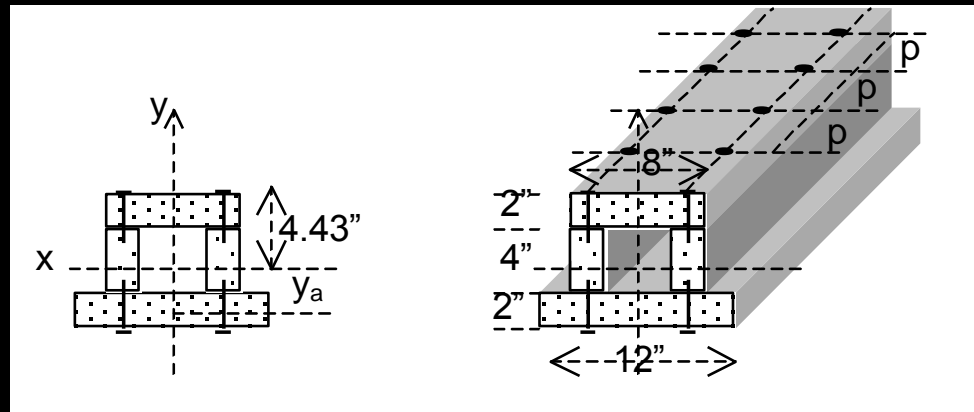

$$\frac{V_{longitudinal}}{p} = \frac{VQ}{I}$$

$$nF_{connector} \geq \frac{VQ_{connected\ area}}{I} \cdot p$$

Vertical Connectors

- isolate an area with vertical interfaces

$$nF_{connector} \geq \frac{VQ_{connected\ area}}{I} \cdot p$$

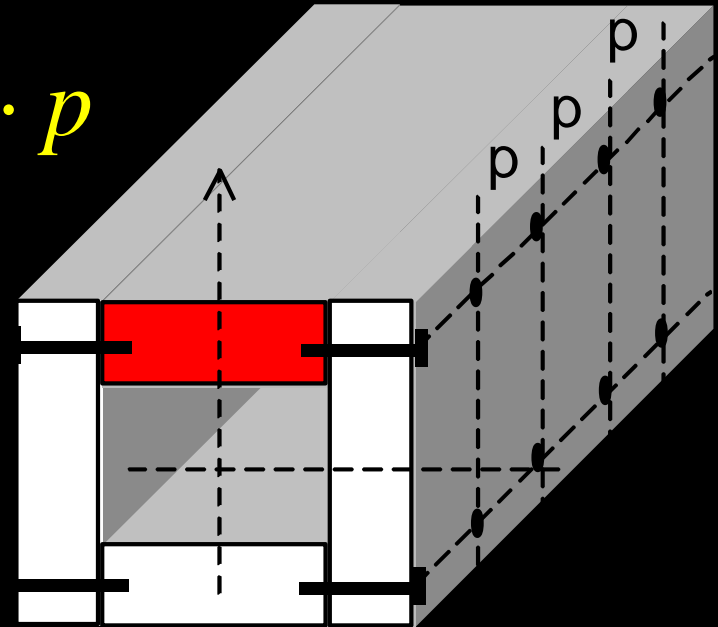

Unsymmetrical Shear or Section

- *member can bend and twist*
 - *not symmetric*
 - *shear not in that plane*
- *shear center*
 - *moments balance*

