

EXAMPLE CARDBOARD COUCH-SWING PROJECT REPORT - PART I  
ARCH 614

TEAM UMIZOOMI

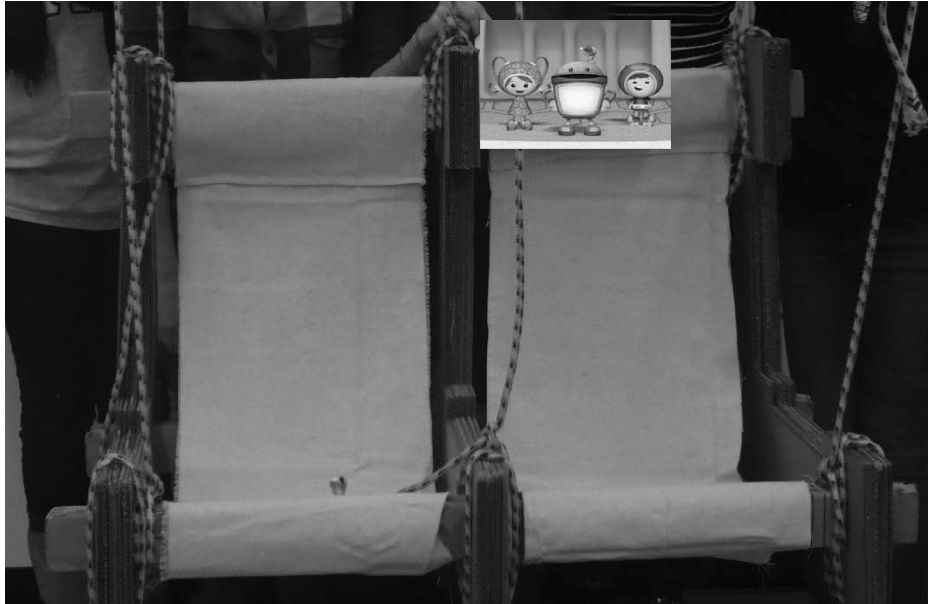

**Project Description:**

Our cardboard couch has L-shaped side and middle members connected by rails of stacked cardboard with seats of white canvas accented by yellow and black diamond-braid nylon rope.

**Project Objectives:**

Our cardboard couch meets the requirements that it "looks good" using the proper materials (with no lamination), supports the two loads due to gravity of 55.2 kg and 58.2 kg comfortably facing forward. Our team worked together to meet the objectives and produce a stunning report.

**Materials and Quantities:**

Rails (top back and front): There are a total of 39 pieces of dimension 70 mm x 1080 mm (0.0756 m<sup>2</sup>)

Side chair pieces: There are a total of 30 L-shaped chair pieces that were 700 mm tall and 710 mm wide for a total area each of 0.1748 m<sup>2</sup>

Seat canvas: There are two seats with a width used of 400 mm and length of 1.35 m for a total area each of 0.54 m<sup>2</sup>. 1 m of heavy duty upholstery thread was used to sew the seat to the front and top rails.

Rope: There are three longer ropes of 1.75 m each, and three shorter ropes of 1.5 m in length for a total of 9.75 m. The nylon rope has a test strength of 150 lb.

Summary: A total of 8.1924 m<sup>2</sup> of recycled cardboard was used.

### **Design Process:**

Our team was inspired by the geometric architecture of the firm Milli Geo and Bot, Ltd., famous for the design many buildings in Umi City. We wanted to make the couch as small and as lightweight as possible, but found that in our first design the cross section of the side and rail members were just too thick, and the seat base was too small.

In our revised design, we were careful not to glue the strips we wanted to use to make our frame members out of, but wanted to make them wider than a single ply of cardboard. In order to hold our strips together we chose to make slots in our side chair members. We wanted to avoid using glue altogether to keep the structure pure, and so the joints for the top rails and front rails were reinforced with the rope tied around the joints in a figure-8 and took advantage of friction.

We found that by cutting a slot for the assembly of the rails, that we needed to increase the thickness around the hole so that the members would not pull out or rip. We were also careful not to splice or join any of the side or rail members to avoid any ripping or twisting at those locations.

We chose a neutral canvas color so that the couch will reflect the colors of the clothing of the occupants and allow them to blend in with the architecture. We folded it over on each side to strengthen and stiffen the cut edges. We carefully sewed it around the top and front rail and used lots of knots and extra thread for redundancy in case any pulling would open the fabric joint.

The rope color was also chosen carefully. We believe this color has high impact and visibility, so that the occupants can easily find where to sit and how to swing. Anchor-hitch sailor knots were used to tie the loops for the clips and around the chair members to rail connections.

### **Anticipated Behavior:**

We expect that when the two load are seated on the structure, it will sag when the ropes stretch, but will still be high enough for the requirements. The fabric of the seats will go taught and pull tightly on the top and front rails. The back rail should remain straight. The vertical force pulling down on the top and front rails will try to twist the vertically stacked cardboard, but it should act as a unit. The ropes should transmit the pull on the rails into the sides and up to the test frame at the chains.

Our loads will swing happily for more than the comfortable resting time required.

Plans:

Front Elevation (mm)

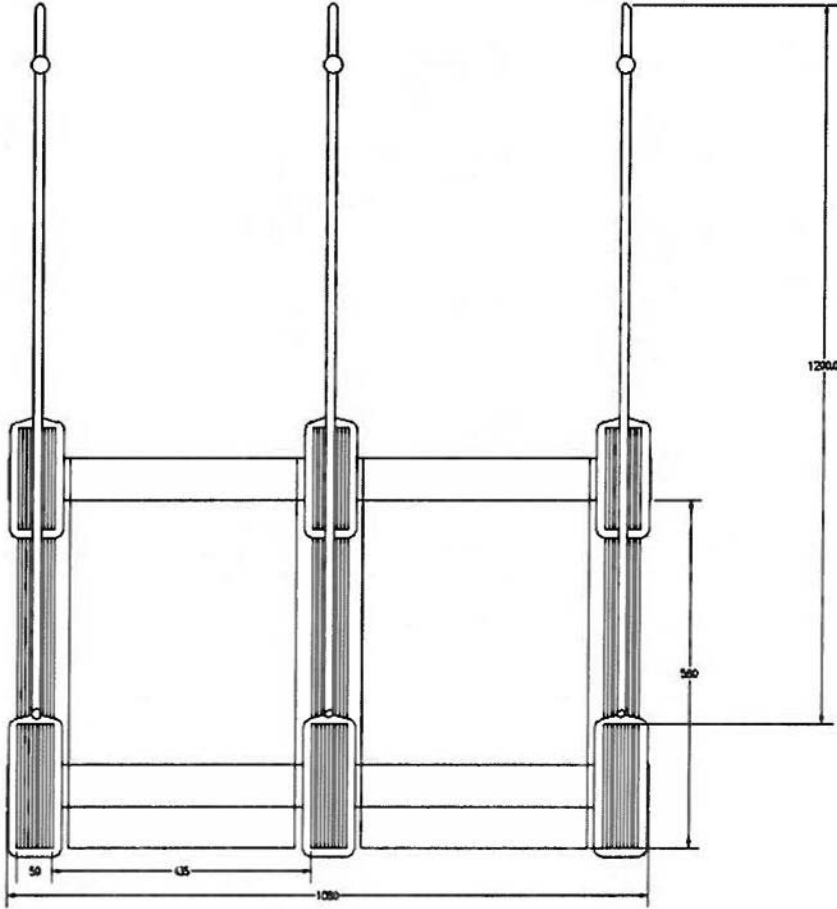

Plan (mm)

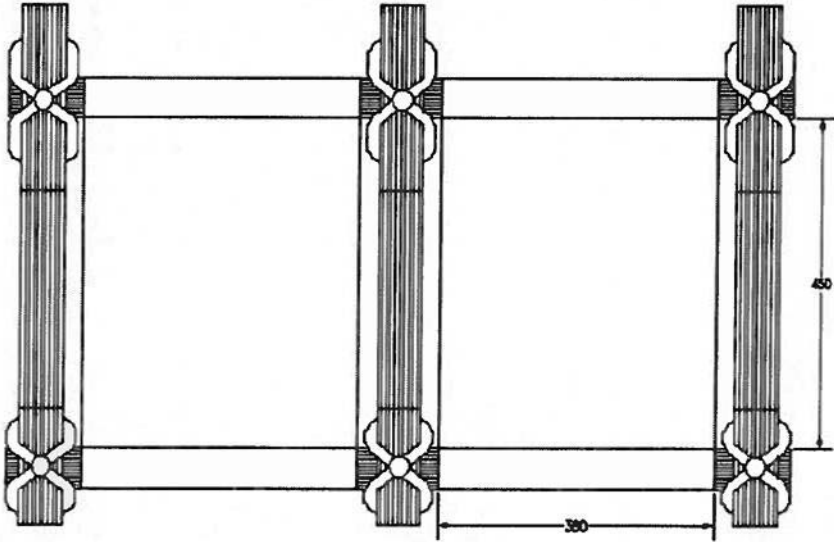

Side Elevation (mm)

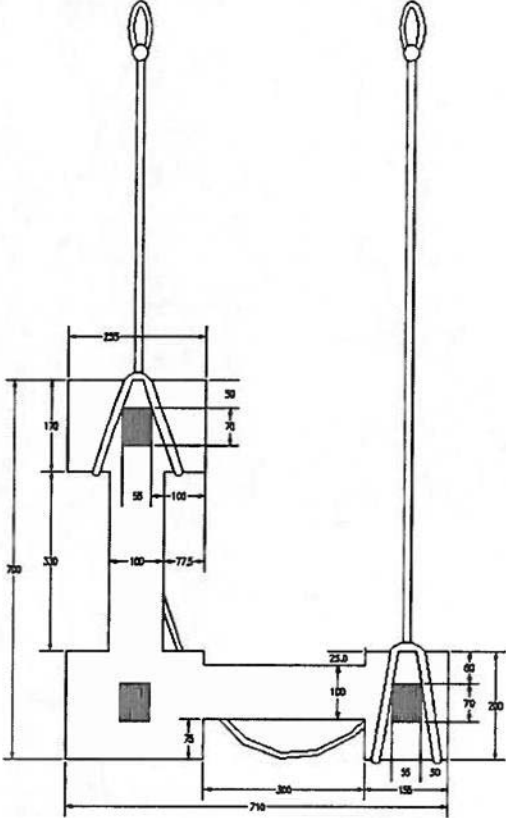

Joint Detail

