



Example
Cardboard Swing Couch Project:
Part II
Team C²+A²

ARCH 614: Elements of Architectural Structures
Prof. Anne Nichols
2010

Contents

- Introduction** 1
- Design** 1
 - Project Development 2
- Construction** 3
 - Materials and Specifications 4
 - Assembly 4
- Performance** 5
 - Mechanical Testing 6
 - Structural Modeling 6
 - Evaluation 9
- Enhancement** 10
 - Exploration 10
 - Revision 12
 - Structural Modeling 12
- Effect** 13
 - Stresses 15
 - Deflection 16
- Summary** 16
- References** 17
- Appendix** 18

Introduction

The cardboard couch-swing project consists of two parts. The first part was the construction of a swing of original design to hold two people comfortable using only recycled single-ply corrugated cardboard, cloth, rope and glue. This couch was tested on February 2, 2010 and a brief report was submitted. The second part of the project was an evaluation of the structure to determine how the structure can be improved using tools and knowledge acquired through this course, and documentation of an investigation for and evaluation of changes to the original design.

This report documents the history and the evolution of the design through the application of structural principles. The structural response of the swing as it was built (*prototype*) and the swing as it is envisioned (*design development*) will be examined in detail. Supporting experimental work as it relates to the structural analysis is presented along with the design decisions based on the modeling results.

Design

The design of the cardboard couch-swing had to meet the requirements that the cardboard shapes be made by hand and that they not be laminated using flat sheets with glue. The loads were from classmates with masses of 54.8 kg (121 lb) and 79.8 kg (176 lb)¹, respectively, and the loads would choose which side of the couch they would sit on. The couch had to have cardboard members to provide stiffness, especially for the seating which had to be constructed using only cloth (no rope reinforcement). Only one frame member was allowed between the seats within the base perimeter. The cross section of the members were restricted to a maximum dimension of 75 mm x 100 mm (2.95 in x 3.94 in.)

The couch had to fit within a 1.8 m ((5.9 ft) width of the test frame and could be suspended by a as few as 3 ropes and as many as 6 ropes with looped end attached to carabineers clipped to chains around any of 3 parallel top rails (Figure 1).

¹ Using the ACI Structural Journal format



Figure 1: Couch-Swing and Frame

Project Development

The team began by exploring the main structural material for the project in order to determine the best way to create a strong structural component to be used as a repeating unit in the assembly. Previous prototypes (from other student projects) used box shapes, triangular tube shapes, stacked flat sheets with separators, and rolled tubes (being the most frequent shape). A box shape was originally chosen (see Figure 2), but the method to connect the bars appeared complicated. The tube shape was chosen using rope to connect them, and it was found that by tightly rolling the tubes the members were quite stiff and could support 125 lb in tension.

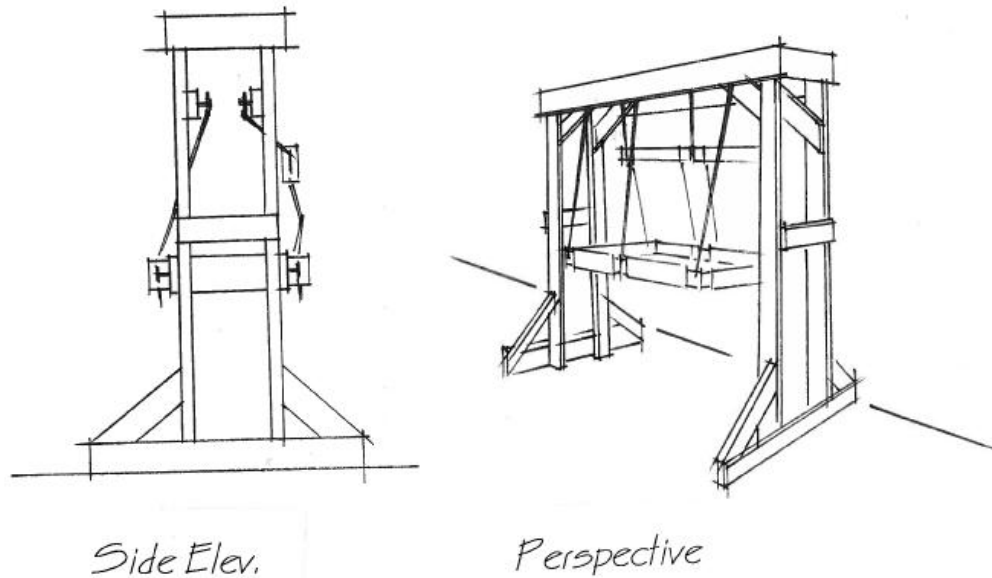

Figure 2: Preliminary Design

With the basic component shape determined, the program requirements of comfort and size limits informed the design and structural decisions. The area for each seat base was chosen as 610 mm (24 in) deep and 680 mm (26.8 in) wide to provide adequate area. The seat back was chosen as 610 mm (24 in) in height to allow for a comfortable reclining angle and prevent the user's body from curling up into an uncomfortable c-shape curve! Cardboard tubes would form the seat perimeters with rope tying the tubes together. Tubes would be provided to support the cloth for the seat back and bottom which spanned front to back. The maximum number of 6 ropes to support the couch was chosen.

Construction

The couch was constructed using two tubes having lengths of 760 mm (29.9 in) each for the front and rear of the seat, three tubes having lengths of 610 mm (24 in) at the edges of each seat, and two smaller tubes having lengths of 760 mm (29.9 in.) each for the top of the seat backs. A 3-layer fabric panel was sewn around the seat back top tube to the seat back bottom tube, and another was sewn from the seat back bottom tube to the front tube for each seat.

Materials and Specifications

A total of 4.5 m² (48.4 ft²) of recycled cardboard was used. Four 1.18 m x 1.18 m (30" x 30") pieces were cut for the front and back tube members. Two 1.18 m x 0.79 m (30" x 20") pieces were cut for the seat back tubes. Three 0.94 m x 1.18 m (24" x 30") pieces were cut for the side and middle tubes of the seat base. All tubes were rolled to no more than 75 mm (3 in.) in diameter. A lightweight, woven water resistant Nylon fabric was cut into twelve pieces of 0.94 m x 1.42 m (24" x 36") for a total of 2.2 m² (24 ft²). 3/8" diameter Nylon rope of 0.8 kN (175 lb) test was cut into two lengths of 7 m (23 ft) for the front and rear, one length of 6.4 m (20.9 ft) for the middle two hangers, two lengths of 2.6 m (5.3 ft) for the seat base ends, and two lengths of 1.7 m (5.5 ft) for a total of 27 m (88.5 ft).

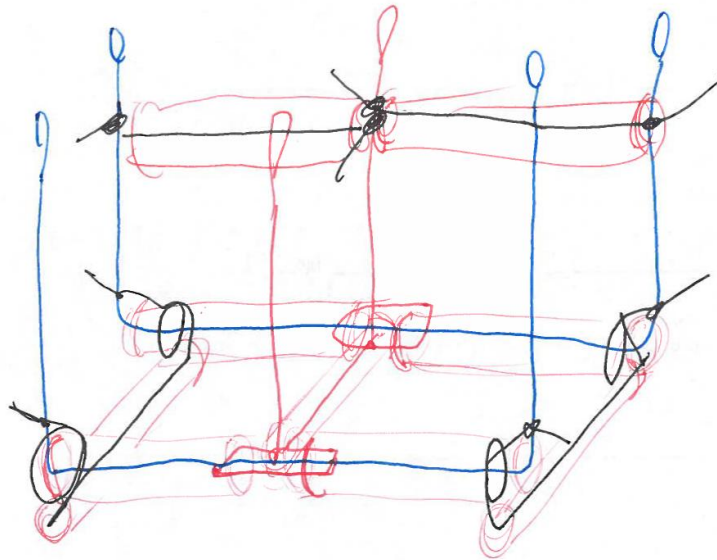

Figure 3: Rope Diagram

All specification drawings, including plan, elevations and joint detail are provided in the Appendix.

Assembly

The cardboard tubes were rolled prior to threading the rope through the tubes. After rolling the first tube, we discovered that threading the rope was a trial-and-error process. We quickly learned to place the roll in the cardboard and then roll it into the tube, which meant we had to carefully order adding each additional piece!

The front two tubes of the seat frame were rolled with one rope, and the back two tubes of the seat frame were rolled in the same manor. The perpendicular tubes in the seat frame and the seat back tubes were rolled with one rope. The ropes were tied around the front and back seat frame tube assemblies and knotted, while the middle tube was carefully threaded through holes cut through the diameter of the tubes at the intersection (as seen in the Appendix). Knots were used to tie the seat back tubes to the side and middle back ropes. All hanging ropes were measured and 100 mm (3.9 in) long loops were knotted to clip on the carabineers.

Three layers of the seat and seat back material were hemmed together at the side with seam binding. One end was cut in a saw-toothed manner with our design of interlocking pieces at the lower back of the seat to allow this location, expected to hold the most weight, to be strong while creating a large and comfortable back to sit on at a comfortable angle of no more than 30 degrees. The fabric tabs were wrapped around the tubes and sewn into place. The fabric at the front and top of the seat was wrapped around the tubes and sewn into place

Performance

The anticipated behavior of the constructed couch-swing consisted of the following:

1. The seams of the material could rip, tear or pop due to the tensile forces in the material. To minimize this problem, we selected a nylon material that we anticipated would stretch, but not excessively. We also provided three layers of the material to share the stress and provide a safety net. With the addition of seam binding we anticipated the material would rip before the seams would break.
2. The ropes that connect the cardboard tube could press in on the cardboard or possible tear through the holes made when the stress from the loads are distributed. We tried to reduced the stresses by minimizing the number of connection points, drilling as few holes as possible, and putting the rope through the middle of the rolled tubes.
3. The tied joints of the front and back rails to the perpendicular members of the seat base could slip off when the load is distributed to the hanging ropes.
4. The hanging ropes will stretch, and not break under the anticipated loads distributed to 6 ropes. We were unable to hang the frame and test this theory before testing.
5. The cardboard tubes may bend or break when the load is applied, but we believed the thickness and short length of the tubes will distribute the stress more evenly.

Mechanical Testing

When the couch-swing was loaded, it behaved well under the load by supporting the occupants. The fabric stretched, while the tubes moved somewhat independently because of the flexible rope joints. The tubes supporting the seat fabric did bow a little. In addition, the seat backs were pulled "up" vertically from the top of the occupants' shoulders, which did not allow the occupants head to recline comfortably.

Structural Modeling

From the mechanical testing, it was anticipated that the weakest member would be the cardboard tube and that the original design would distribute the total load from the occupants evenly over the front and back tubes once seated. While the occupant was sitting, however, the total load would be distributed over the front rails based on each occupant's force due to gravity (54.8 kg and 79.8 kg or 121 lb and 176 lb). The tension force in side ropes would be roughly half of the tension force in the middle ropes of 330.25 N and 660.5 N (74.25 lb and 148.5 lb), respectively.

The model was constructed in Multiframe[1] with rotational releases at the joints for the rope ends and for the front and back tubes at the middle cross tube (Figure 4). (Releasing too joints many made it unstable). Two load cases were considered. When the occupants were sitting, distributed loads of the total weight of each load were applied to the front tubes (Figure 5a). When the occupants were seated the 1/3 the total distributed loads was applied to the seat base front, 2/3 was applied to the seat base back, and 1/4 was applied to the seat top tubes (from the pulling of the seat) in addition to a lateral distributed load of 1/8 (from the occupants back and head) (Figure 5b).

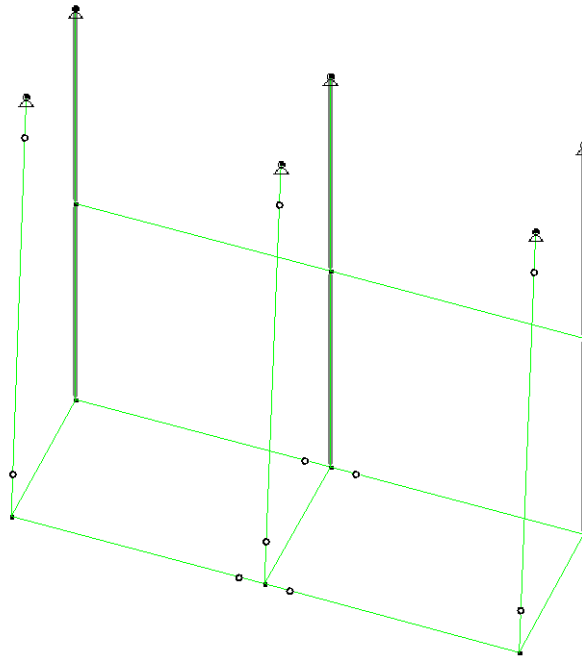

Figure 4: Model of Couch-Swing

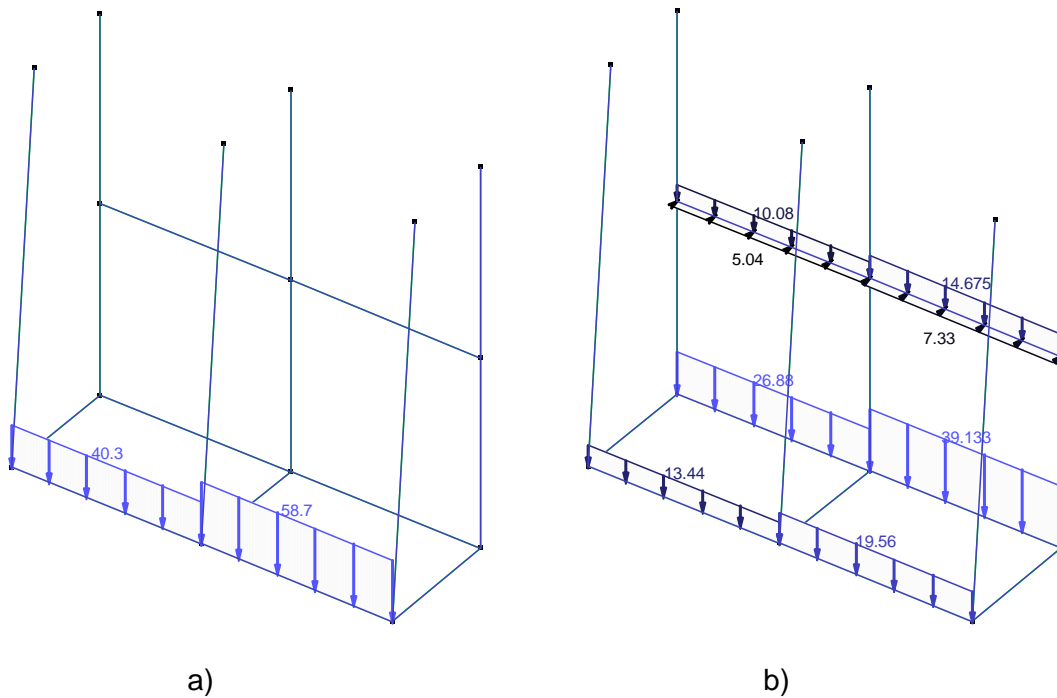

Figure 5: Load Cases a) 1- all load on front, b) 2- load to seat and back

The results of the modeling are shown in Figure 6 (Case 1 with loads on front only) and Figure 7 (with loads to front and back). For case 1, the bending moment is highest at the back

connections and at the midspan of both front tubes. The maximum shear occurs in the front tubes at the middle joint, while the maximum tensile force in the ropes is in the middle front. For case 2, the bending moment is highest at the back connections and at the midspan of both rear tubes. The maximum shear occurs in the back tubes at the middle joint, while the maximum tensile force in the ropes is in the rear middle tube. For both loadings, the deflection shows that the couch will swing forward, with a little more swing with case 2.

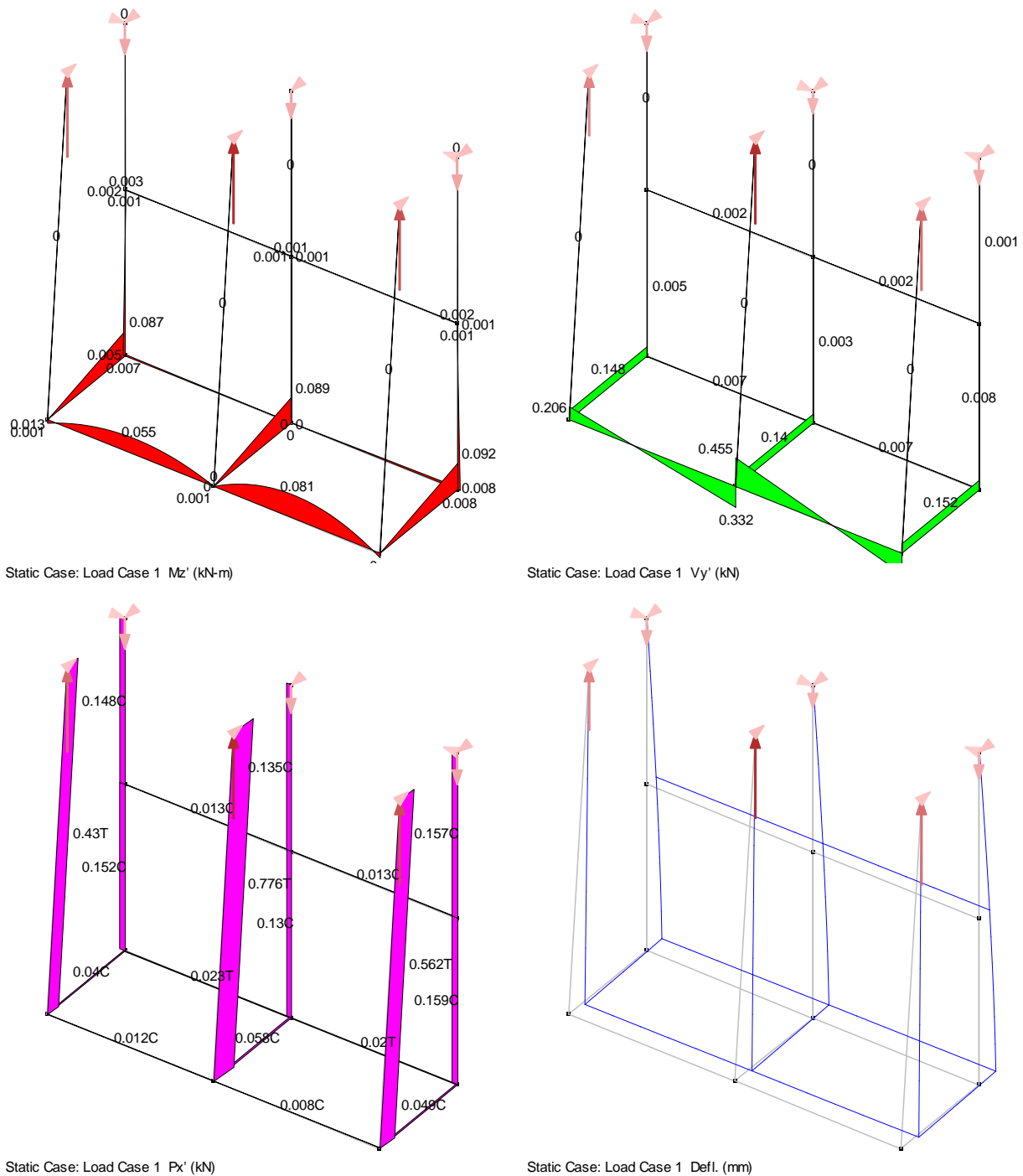

Figure 6: Load Case 1 Results

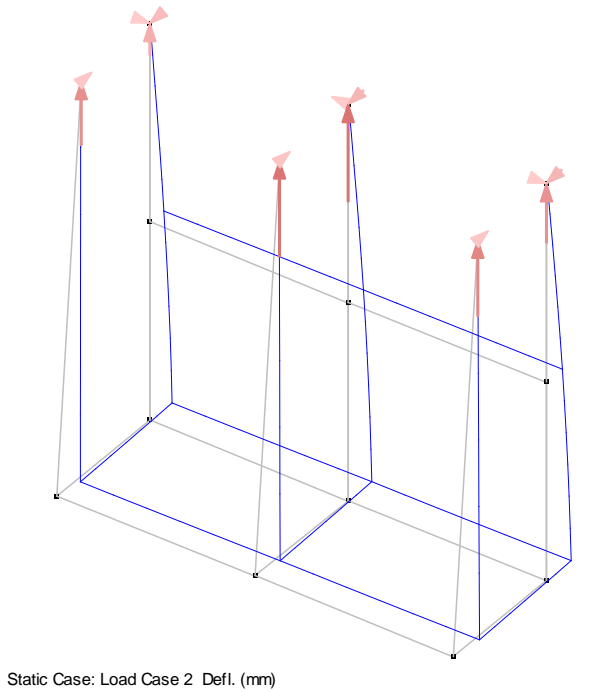
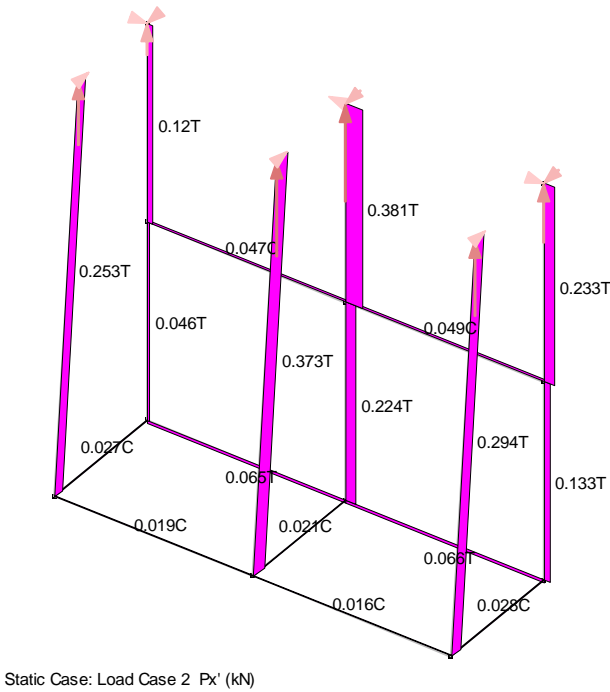
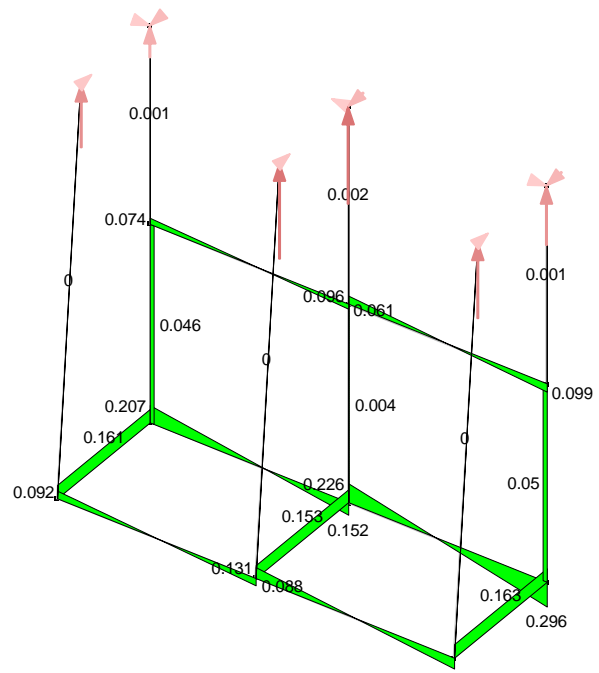
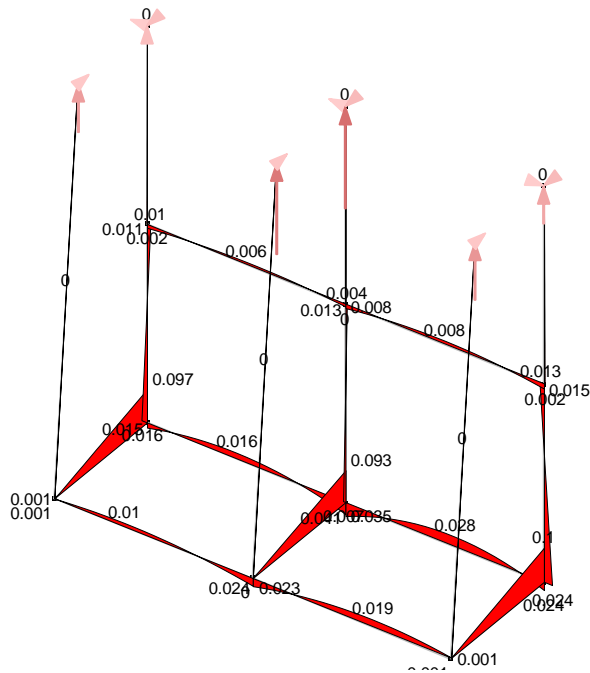

Figure 7: Load Case 2 Results

Evaluation

The results suggest that the front tubes need to resist larger bending stresses than the rear tubes, so that the sizes can be adjusted accordingly. The results also show that there are large

bending moments which will result in large connection stresses at the rear tube. The results also show that the largest rope force is 0.778 kN (174 lb), while the rope test strength is 0.8 kN (175 lb). This suggests that the rope is adequate, but could be unsafe for heavier occupants.

Enhancement

The mechanical testing of the couch-swing provided visual data on the functionality and the locations of high stress as indicated by deflections, motion, and compressing of joints. The structural modeling of the frame provided analysis results based on assumptions of the joints and supports of the swing. In order to make design decisions using the analysis data, we needed to obtain some information about the material strength and serviceability limits of our materials.

Exploration

In order to investigate the material strength and limitations of the materials used, a full scale test was performed on the as-constructed couch-swing. (*NOTE: This is not the material testing specified in the current instructions which ask the teams to investigate material properties and strength separately from the constructed unit.*) The couch-swing was hung from a porch roof, and two plastic containers were suspended from a Nylon rope at the center of one member to create a single concentrated load at the point expected to create the largest bending moment. (See Figure 8) The load applied at rupture could be then used to determine what an equivalent distributed load would be for the same bending moment. 14.25 gallons of water were added to the containers at the point the beam-tube failed, representing a load of 529.3 N (119 lb). For the 0.91 m (36 in.) beam member, the maximum bending moment is $PL/4$ or 129.5 N-m (95.5 lb-ft). The total distributed load can be found from $1/8wL^2$ and is 1157.5 N/m (79.3 lb/ft). With an estimated cross section modulus (based on a solid tube) of $\pi d^3/32 = 43,437.5 \text{ mm}^3$ (2.65 in³), the maximum stress is 3.0 MPa (432 psi).



Figure 8: Testing for Bending Capacity

The seat material was tested by hanging the plastic containers at the center of the remaining seat. A total of 16 gallons of water, representing 594.25 N (133.6 lb) at the capacity of the containers was applied with no noticeable fault. *(NOTE: A more appropriate way to find the properties of the fabric was to perform a tensile test and measure the force and displacement to determine how much it would stretch if it was not possible to load it to failure.)*

The Nylon rope was tested by suspending the two plastic containers from the ropes. A total of 16 gallons of water was applied resulting in a lengthening of the ropes stretched 23 mm (0.9 in.) and did not fail at the capacity of the containers.

Revision

To reduce the bending stresses in the tubes, the suggestions were to reduce the length or to make the front and back tubes continuous, however continuous beams have larger shear force at the middle support. This could reduce the amount of cardboard needed and reduce the cross section size of the tubes if shear is adequate.

The observations of the testing suggested the three layers of fabric for the seats was more than adequate and could be reduce to two layers. The height of the back was too tall for occupants with height under 1.8 m (6 ft) and that the seat depth was also too deep for these occupants. The revised couch will reduce the side dimension of the seat base from 0.61 m to 0.30 m (24 in to 12 in), and reduce the height of the seat back from 0.61 m to 0.36 m (24 in to 14 in). The front and rear tubes will be reduced from 0.76 m to 0.46 m (30 in. to 18 in.) The revised plans are provided in the Appendix.

Structural Modeling

The model members were shortened, and the joint at the middle front and back tubes was made rigid, while the joint at the rear of each seat cross member was released (Figure 9). The front joint of the middle cross member was released. The only way to model the tension force in the middle front rope was to provide a support. The loads were determined in the same manner as for the as-built model by taking the total load of each person and distributing over the length (now shorter), increasing the loads for each case.

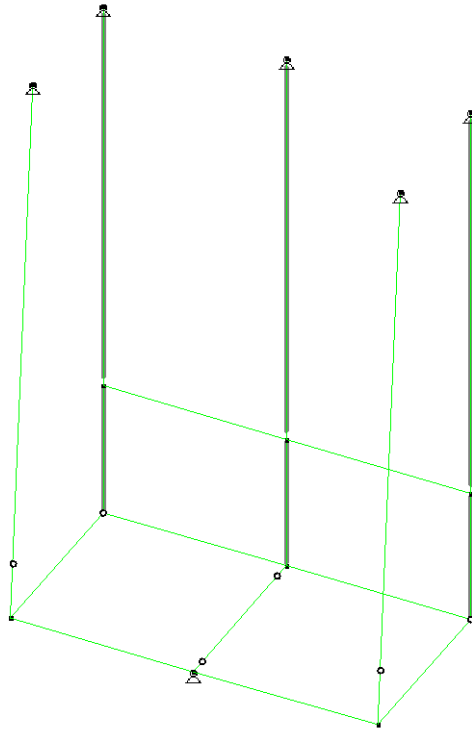
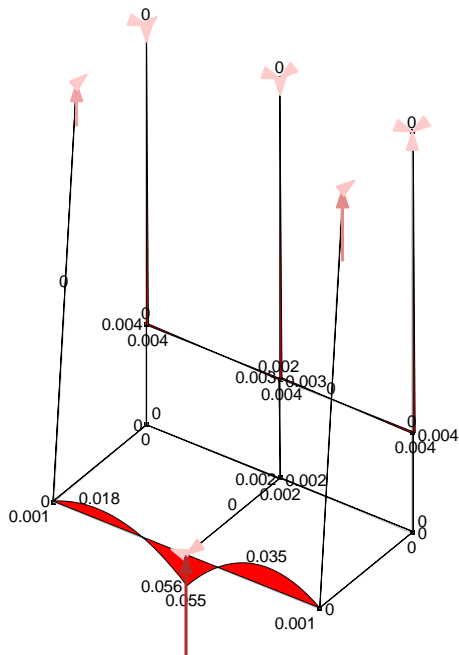

Figure 9: Model of Couch-Swing Revision

Effect

The revisions reduced the size of the bending moment in the front tube under load case 1 (Figure 10), but had little effect on the size of the bending moment on the rear tube under load case 2 (Figure 11). The change to the seat frame cross tubes was significant, in that the bending moment was virtually eliminated and the members became axial members in compression in case 1 and tension in case 2. The size of the shear in the front tubes increased, but not a great deal from the as-built model analysis shows.

The size of the tension for case 1 in the middle rope from the support reactions is nearly 0.84 kN (190 lb), which is over the test strength amount, so that a larger test strength rope would be required. The force in the back middle rope in case 2 has nearly doubled, but is still under the maximum of 0.84 kN of case 1.



Static Case: Load Case 1 M_z' (kN-m)

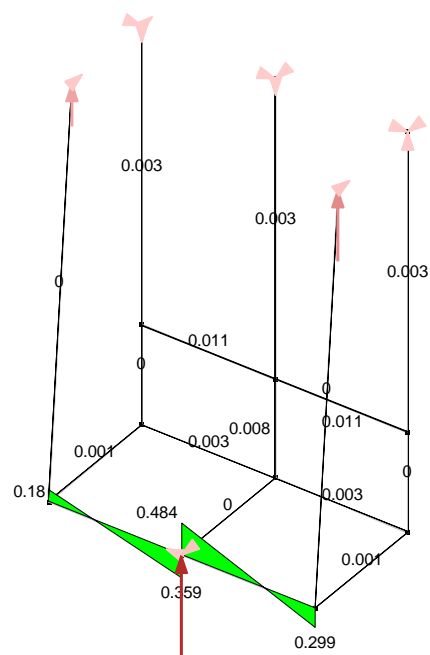

Static Case: Load Case 1 V_y' (kN)

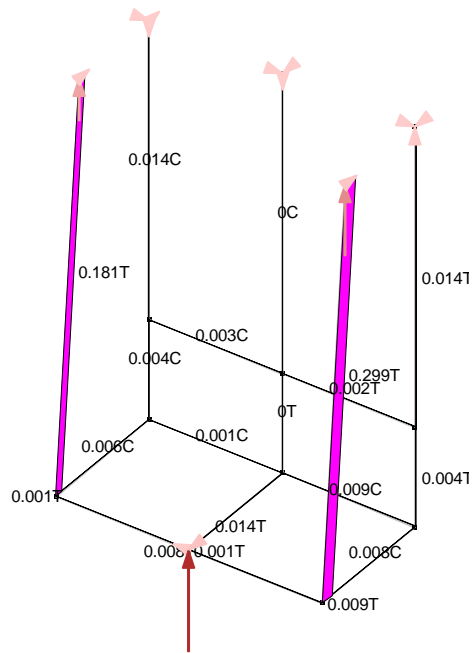

Static Case: Load Case 1 P_x' (kN)

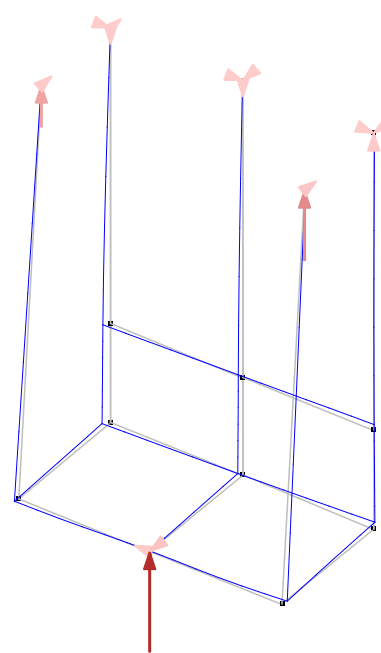

Static Case: Load Case 1 Defl. (mm)

Figure 10: Load Case 1 Results for Revised Model

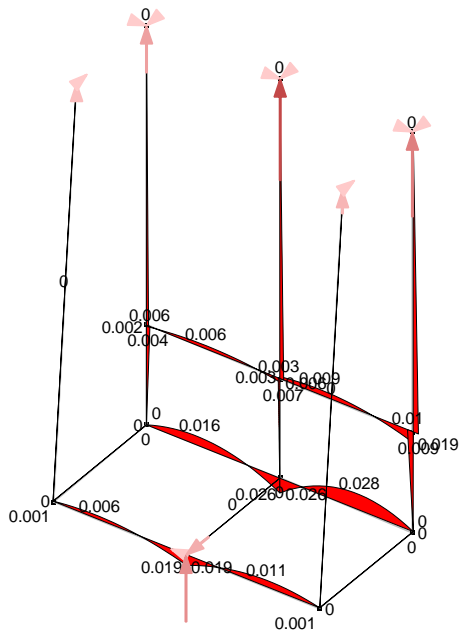

Static Case: Load Case 2 Mz' (kN-m)

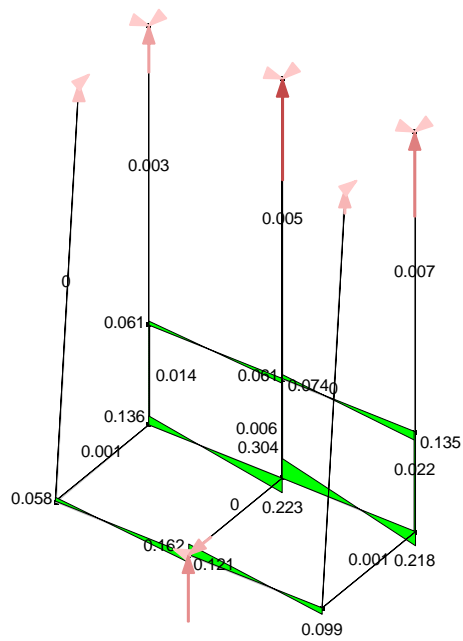

Static Case: Load Case 2 Vy' (kN)

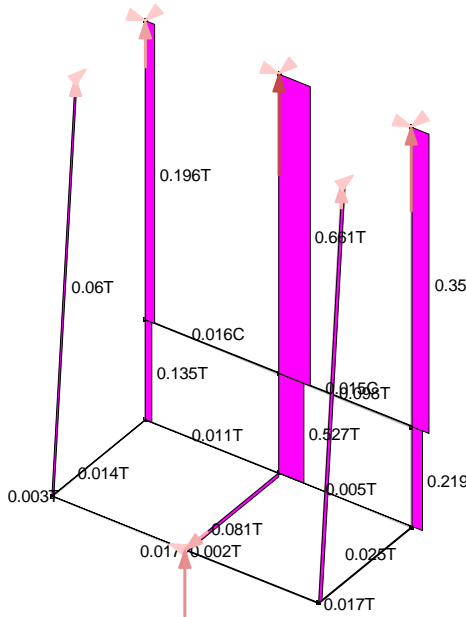

Static Case: Load Case 2 Px' (kN)

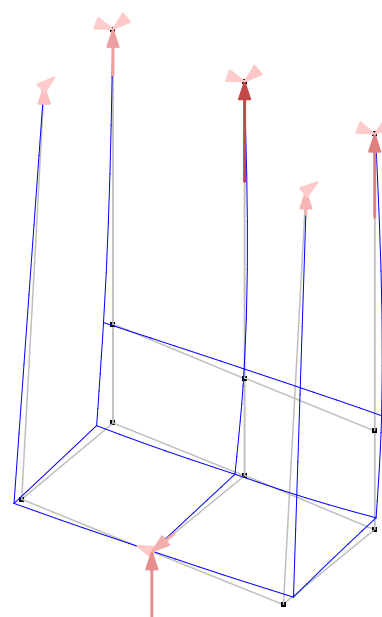

Static Case: Load Case 2 Defl. (mm)

Figure 11: Load Case 2 Results for revised model

Stresses

If the maximum bending stress from testing was found to be 3.0 kPa (432 psi), the required diameter of a "solid" cardboard tube can be determined from the section modulus found from $0.056 \text{ kN-m} / 3.0 \text{ MPa} = 18,667 \text{ mm}^3$ and using $\frac{\pi d^3}{32}$ to be 26.5 mm (1 in.) This small diameter,

unless the shear strength of cardboard is quite high, would probably not be large enough to resist the shear forces.

Deflection

Because of the modeling with a support for the design revision, the deflections do not appear to be as large, although it is interesting that the frame appears twist in the direction of the larger load in both load cases. With the concentration of load over a shorter length, the back rests appear to move further back, most likely providing the occupant comfort level envisioned.

Summary

This report documents the construction and structural analysis of a cardboard couch-swing. In order to investigate the efficiency of the design in terms of strength and serviceability, we investigated the material properties in order to evaluate the results of the load analysis for two cases - with the occupants sitting on the front tubes as they got into the couch and when the occupants were completely seated with their back against the seat back fabric.

The analysis showed that large bending moments were produced by the way the joints were assembled using flexible ropes at some joints, and overlapped tubes tightly bound at others. With this information, and the observed behavior when the couch-swing was loaded and tested, design revisions were identified. The resulting revisions, which included shortening the length of the front, rear, and seat back tubes, shortening the cross members of the seat base, lowering the height of the seat back tubes, and changing some flexible connections to rigid, and rigid connections to flexible, reduced the bending moment and allowing the tube section modulus to decrease, but the changes increased the rope tension which could be accommodated by rope with a larger test strength.

The investigation shows that design revisions are possible based on structural investigation and design principles such as allowable stress design that could reduce the amount of material used and how the material is used effectively. It was also possible to make architectural revisions to improve the occupant comfort level and design to the dimensions of and loads produced by the users of the couch-swing structure.

Acknowledgement

This report was modified from the original work submitted by Team C² (Change of Career), April 2010.

References

- [1] Multiframe 4D software, Version 11.5 (2010). Formation Design Systems, Fremantle, Western Australia.

Appendix

Drawings (with ropes and dimensions required) of Project Report Part I

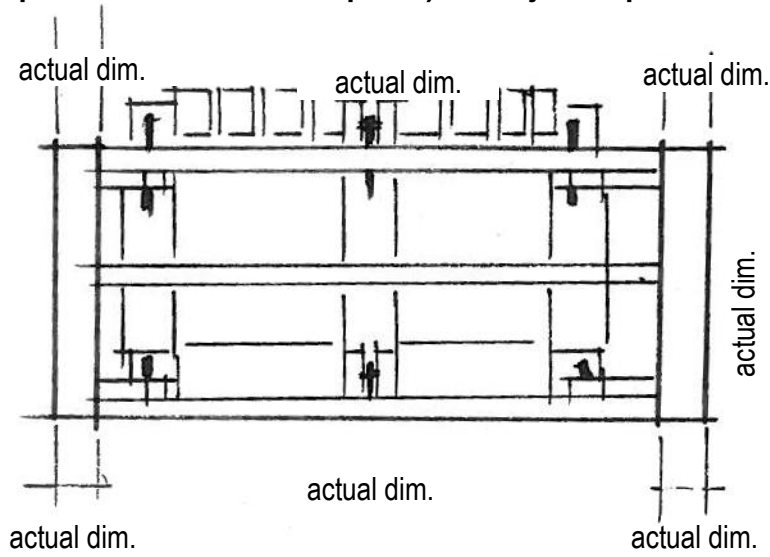

Plan

scale = ?

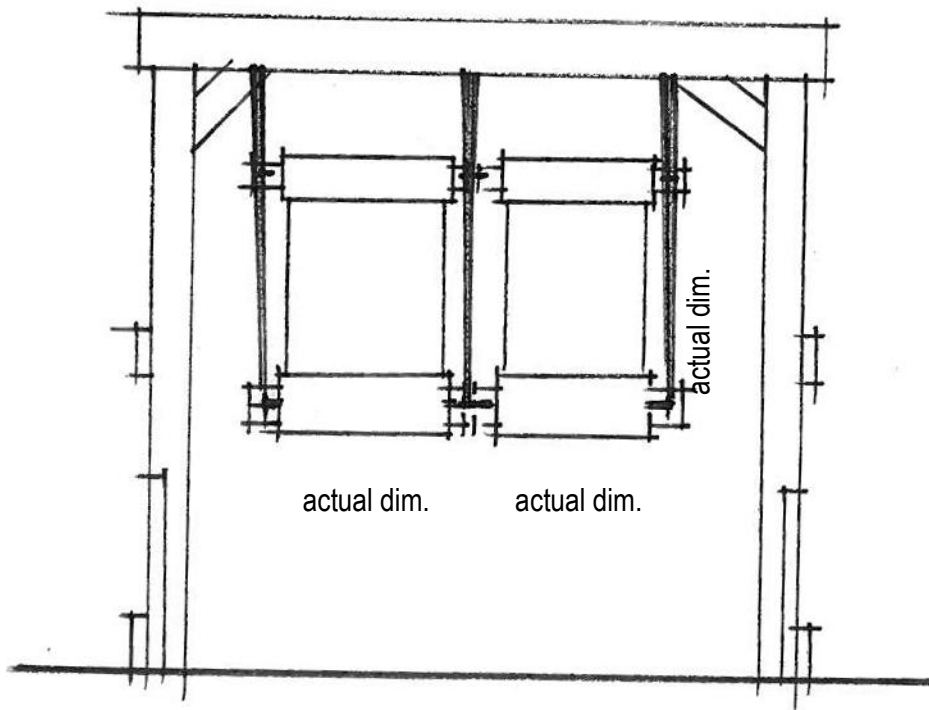

Elevation

Side Elev.

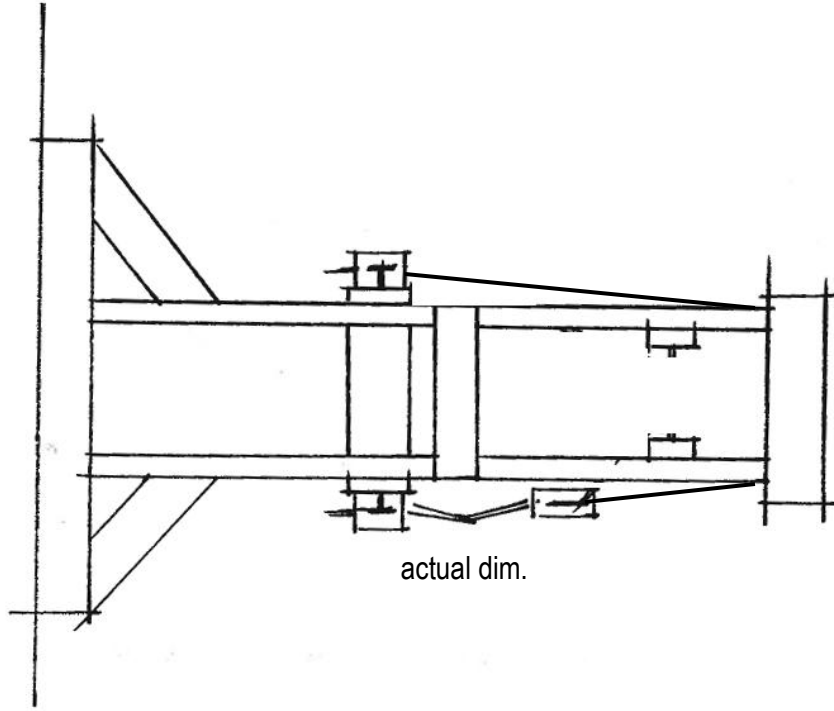

Perspective

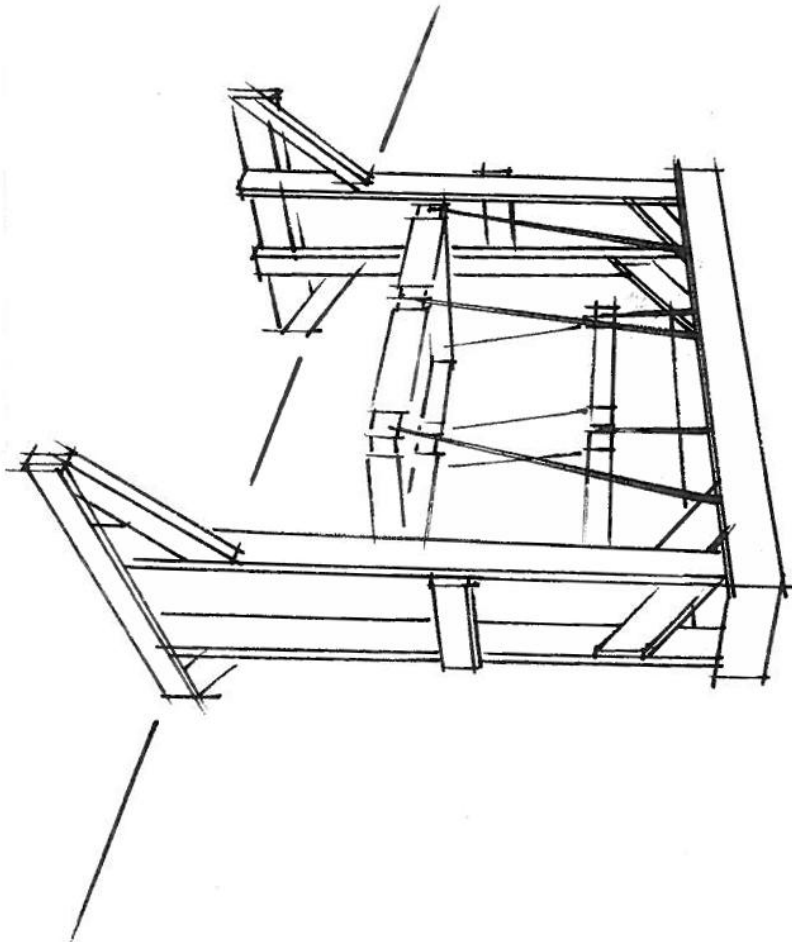

JOINT DETAIL

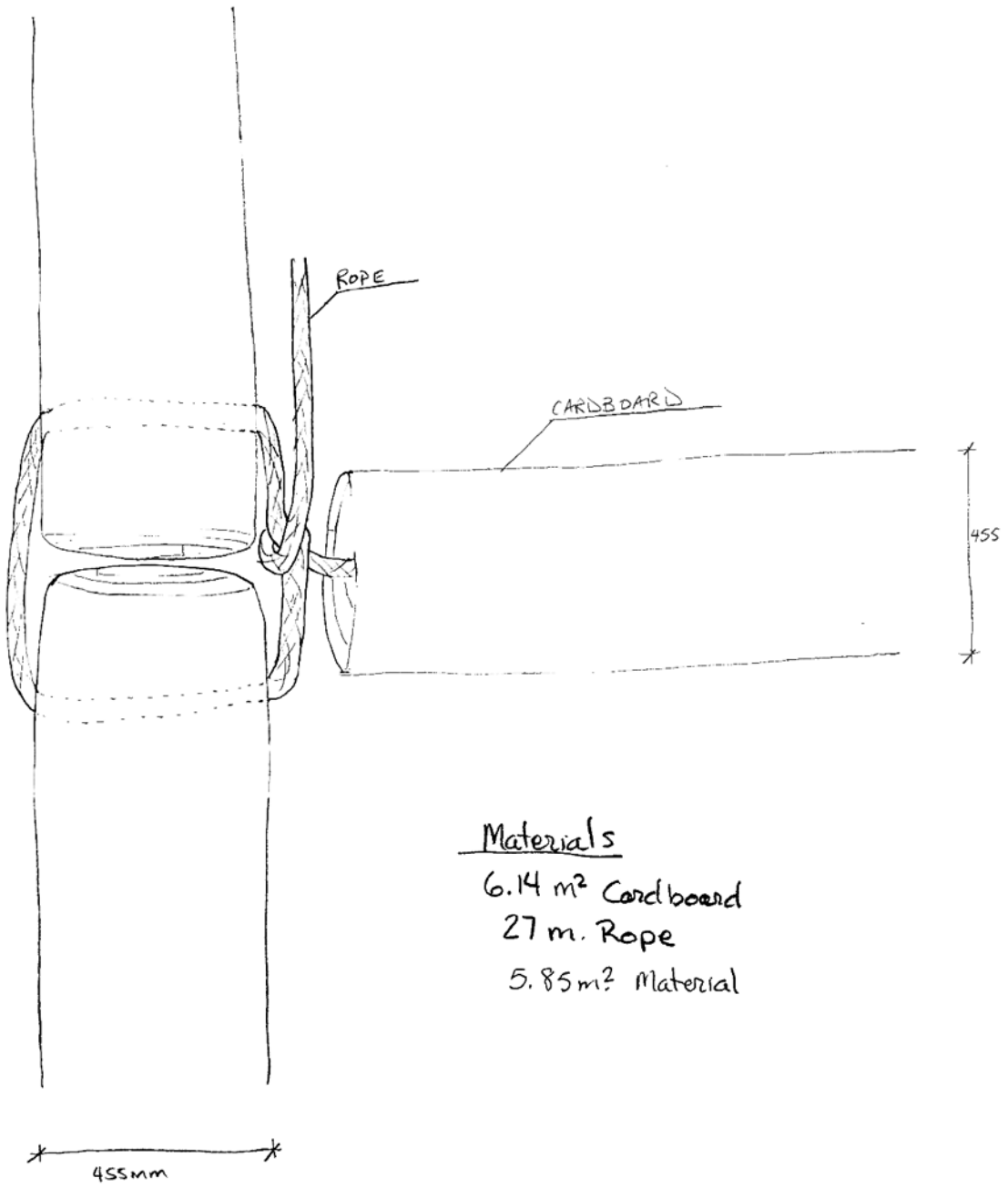

Materials

- 6.14 m² Cardboard
- 27 m. Rope
- 5.85 m² Material

Drawings for Revised Couch Design

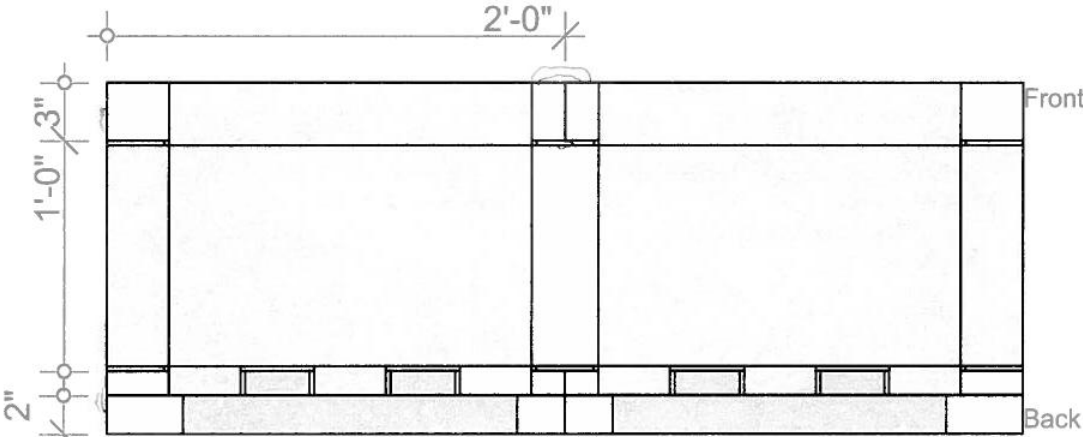

Plan

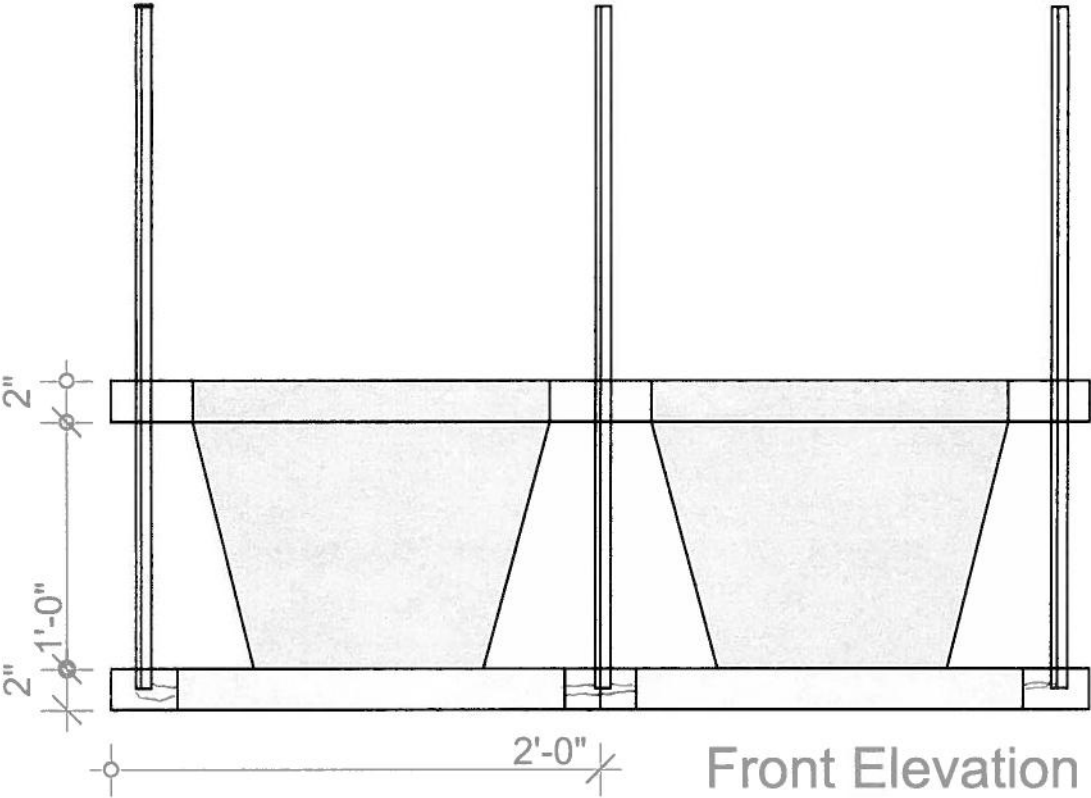

Front Elevation

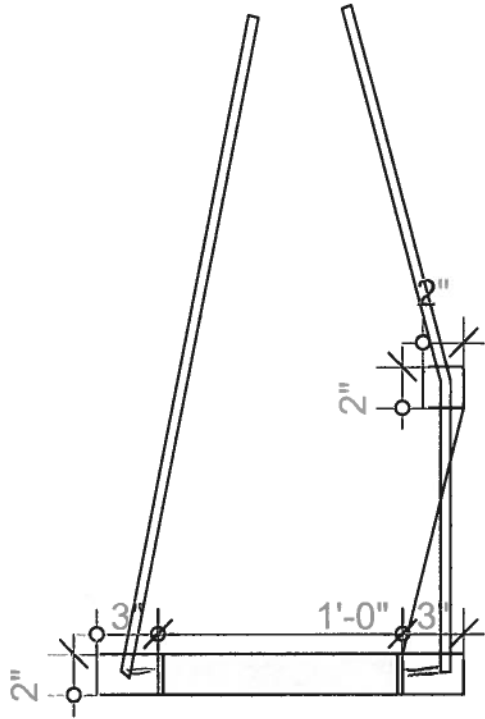

Side Elevation