

Centroids & Moments of Inertia of Beam Sections

Notation:

<p>A = name for area</p> <p>b = name for a (base) width</p> <p>C = designation for channel section</p> <p>= name for centroid</p> <p>d = calculus symbol for differentiation</p> <p>= name for a difference</p> <p>= name for a depth</p> <p>d_x = difference in the x direction between an area centroid (\bar{x}) and the centroid of the composite shape (\hat{x})</p> <p>d_y = difference in the y direction between an area centroid (\bar{y}) and the centroid of the composite shape (\hat{y})</p> <p>F_z = force component in the z direction</p> <p>h = name for a height</p> <p>\bar{I} = moment of inertia about the centroid</p> <p>I_c = moment of inertia about the centroid</p> <p>I_x = moment of inertia with respect to an x-axis</p> <p>I_y = moment of inertia with respect to a y-axis</p> <p>J_o = polar moment of inertia, as is J</p> <p>L = name for length</p> <p>O = name for reference origin</p> <p>Q_x = first moment area about an x axis (using y distances)</p> <p>Q_y = first moment area about an y axis (using x distances)</p>	<p>r_o = polar radius of gyration</p> <p>r_x = radius of gyration with respect to an x-axis</p> <p>r_y = radius of gyration with respect to a y-axis</p> <p>t = name for thickness</p> <p>t_f = thickness of a flange</p> <p>t_w = thickness of web of wide flange</p> <p>W = name for force due to weight</p> <p>= designation for wide flange section</p> <p>x = horizontal distance</p> <p>\bar{x} = the distance in the x direction from a reference axis to the centroid of a shape</p> <p>\hat{x} = the distance in the x direction from a reference axis to the centroid of a composite shape</p> <p>y = vertical distance</p> <p>\bar{y} = the distance in the y direction from a reference axis to the centroid of a shape</p> <p>\hat{y} = the distance in the y direction from a reference axis to the centroid of a composite shape</p> <p>z = distance perpendicular to x-y plane</p> <p>\mathcal{L} = plate symbol</p> <p>\int = symbol for integration</p> <p>Δ = calculus symbol for small quantity</p> <p>γ = density of a material (unit weight)</p> <p>Σ = summation symbol</p>
---	--

- The cross section shape and how it resists bending and twisting is important to understanding beam and column behavior.
- The *center of gravity* is the location of the equivalent force representing the total weight of a body comprised of particles that each have a mass gravity acts upon.

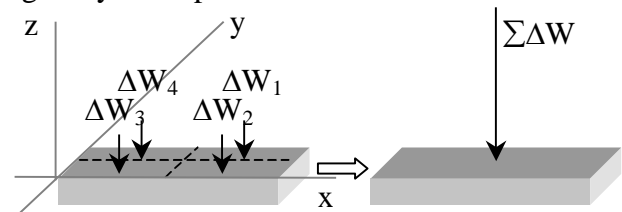

Resultant force: Over a body of constant thickness in x and y

$$\sum F_z = \sum_{i=1}^n \Delta W_i = \mathbf{W} \quad \mathbf{W} = \int dW$$

Location: \bar{x} , \bar{y} is the equivalent location of the force \mathbf{W} from all ΔW_i 's over all x & y locations (with respect to the moment from each force) from:

$$\sum M_y = \sum_{i=1}^n x_i \Delta W_i = \bar{x} \mathbf{W} \quad \bar{x} \mathbf{W} = \int x dW \Rightarrow \bar{x} = \frac{\int x dW}{\mathbf{W}} \quad \text{OR} \quad \boxed{\bar{x} = \frac{\sum(x \Delta W)}{\mathbf{W}}}$$

$$\sum M_x = \sum_{i=1}^n y_i \Delta W_i = \bar{y} \mathbf{W} \quad \bar{y} \mathbf{W} = \int y dW \Rightarrow \bar{y} = \frac{\int y dW}{\mathbf{W}} \quad \text{OR} \quad \boxed{\bar{y} = \frac{\sum(y \Delta W)}{\mathbf{W}}}$$

- The *centroid of an area* is the average x and y locations of the area particles

For a shape of a uniform thickness and material:

$$\Delta W_i = \gamma t \Delta A_i \quad \text{where:}$$

γ is weight per unit **volume** (= specific weight) with units of N/m^3 or lb/ft^3

$t \Delta A_i$ is the volume

So if $\mathbf{W} = \gamma t \mathbf{A}$:

$$\bar{x} \gamma t \mathbf{A} = \int x \gamma t dA \Rightarrow \bar{x} \mathbf{A} = \int x dA \quad \text{OR} \quad \boxed{\bar{x} = \frac{\sum(x \Delta A)}{\mathbf{A}}} \quad \text{and similarly} \quad \boxed{\bar{y} = \frac{\sum(y \Delta A)}{\mathbf{A}}}$$

Similarly, for a line with constant cross section, a ($\Delta W_i = \gamma a \Delta L_i$):

$$\bar{x} \mathbf{L} = \int x dL \quad \text{OR} \quad \boxed{\bar{x} = \frac{\sum(x \Delta L)}{\mathbf{L}}} \quad \text{and} \quad \bar{y} \mathbf{L} = \int y dL \quad \text{OR} \quad \boxed{\bar{y} = \frac{\sum(y \Delta L)}{\mathbf{L}}}$$

- \bar{x} , \bar{y} **with respect to an x, y coordinate system** is the centroid of an area AND the center of **gravity** for a body of uniform material and thickness.

- The *first moment of the area* is like a force moment: and is the **area** multiplied by the perpendicular distance to an axis.

$$Q_x = \int y dA = \bar{y} A \quad Q_y = \int x dA = \bar{x} A$$

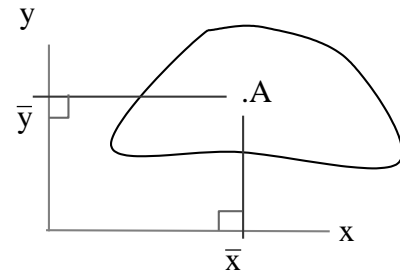

• Centroids of Common Shapes

Centroids of Common Shapes of Areas and Lines

Shape		\bar{x}	\bar{y}	Area
Triangular area		$\frac{b}{3}$	$\frac{h}{3}$	$\frac{bh}{2}$
Quarter-circular area		$\frac{4r}{3\pi}$	$\frac{4r}{3\pi}$	$\frac{\pi r^2}{4}$
Semicircular area		0	$\frac{4r}{3\pi}$	$\frac{\pi r^2}{2}$
Semiparabolic area		$\frac{3a}{8}$	$\frac{3h}{5}$	$\frac{2ah}{3}$
Parabolic area		0	$\frac{3h}{5}$	$\frac{4ah}{3}$
Parabolic spandrel		$\frac{3a}{4}$	$\frac{3h}{10}$	$\frac{ah}{3}$
Circular sector		$\frac{2r \sin \alpha}{3\alpha}$	0	αr^2
Quarter-circular arc		$\frac{2r}{\pi}$	$\frac{2r}{\pi}$	$\frac{\pi r}{2}$
Semicircular arc		0	$\frac{2r}{\pi}$	πr
Arc of circle		$\frac{r \sin \alpha}{\alpha}$	0	$2\alpha r$

- Symmetric Areas

- An area is symmetric with respect to a line when every point on one side is mirrored on the other. The line divides the area into equal parts and the centroid will be on that axis.
- An area can be symmetric to a *center point* when every (x,y) point is matched by a (-x,-y) point. It does not necessarily have an axis of symmetry. The center point is the *centroid*.
- If the symmetry line is on an axis, the centroid location is on that axis (value of 0). With double symmetry, the centroid is at the intersection.
- Symmetry can also be defined by areas that match across a line, but are 180° to each other.

Basic Steps (*Statical Moment Method*)

1. Draw a reference origin.
2. Divide the area into basic shapes
3. Label the basic shapes (components)
4. Draw a table with headers of *Component, Area, \bar{x} , $\bar{x}A$, \bar{y} , $\bar{y}A$*
5. Fill in the table value
6. Draw a summation line. Sum all the areas, all the $\bar{x}A$ terms, and all the $\bar{y}A$ terms
7. Calculate \hat{x} and \hat{y}

- Composite Shapes

If we have a shape made up of basic shapes that we know centroid locations for, we can find an “average” centroid of the areas.

$$\hat{x}A = \hat{x} \sum_{i=1}^n A_i = \sum_{i=1}^n \bar{x}_i A_i \qquad \hat{y}A = \hat{y} \sum_{i=1}^n A_i = \sum_{i=1}^n \bar{y}_i A_i$$

Centroid values can be negative.
Area values can be negative (holes)

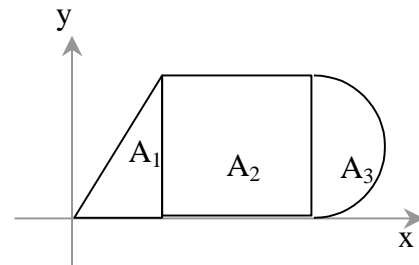

- **Definition: Moment of Inertia;** the second area moment

$$I_y = \sum x_i^2 \Delta A = \int x^2 dA \qquad I_x = \sum y_i^2 \Delta A = \int y^2 dA$$

(or $I_{x-x} = \sum z^2 a$)

We can define a single integral using a narrow strip:

for I_x , strip is parallel to x for I_y , strip is parallel to y

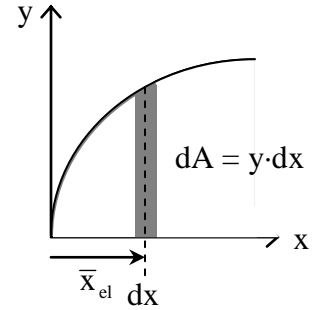

*I can be negative if the area is negative (a hole or subtraction).

- A shape that has area at a greater distance away from an axis *through its centroid* will have a **larger** value of I.

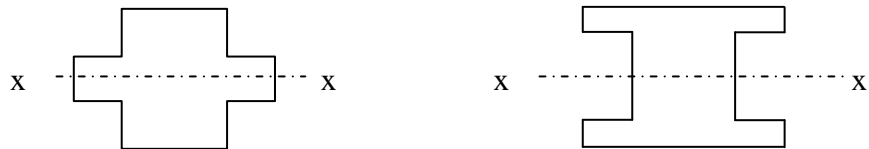

- Just like for center of gravity of an area, the moment of inertia can be determined with respect to *any* reference **axis**.

- **Definition: Polar Moment of Inertia;** the second area moment using polar coordinate axes

$$J_o = \int r^2 dA = \int x^2 dA + \int y^2 dA$$

$$J_o = I_x + I_y$$

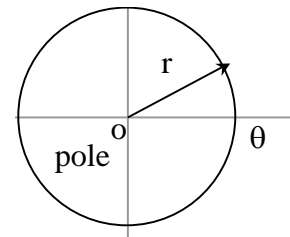

- **Definition: Radius of Gyration;** the distance from the moment of inertia axis for an area at which the entire area could be considered as being concentrated at.

$$I_x = r_x^2 A \Rightarrow r_x = \sqrt{\frac{I_x}{A}} \text{ radius of gyration in } x$$

$$r_y = \sqrt{\frac{I_y}{A}} \text{ radius of gyration in } y$$

$$r_o = \sqrt{\frac{J_o}{A}} \text{ polar radius of gyration, and } r_o^2 = r_x^2 + r_y^2$$

The Parallel-Axis Theorem

- The moment of inertia of an area with respect to any axis not through its centroid is equal to the moment of inertia of that area with respect to its own parallel centroidal axis plus the product of the area and the square of the distance between the two axes.

$$I = \int y^2 dA = \int (y'-d)^2 dA$$

$$= \int y'^2 dA + 2d \int y' dA + d^2 \int dA$$

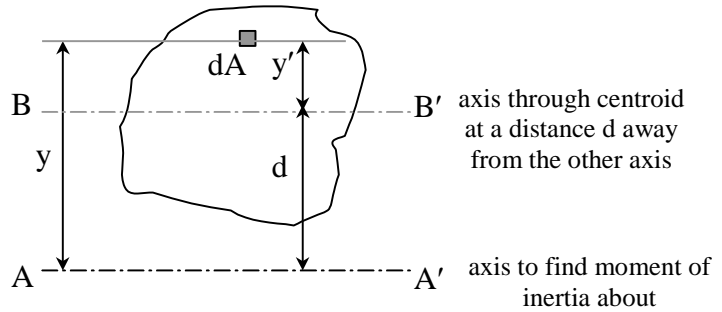

but $\int y' dA = 0$, because the centroid is on this axis, resulting in:

$$I = I_o + Az^2 \quad (\text{text notation}) \quad \text{or} \quad I_x = \bar{I}_x + Ad_y^2$$

where I_o (or \bar{I}_x) is the moment of inertia about the centroid of the area about an x axis and d_y is the y distance between the parallel axes

Similarly	$I_y = \bar{I}_y + Ad_x^2$	Moment of inertia about a y axis
	$J_o = \bar{J}_c + Ad^2$	Polar moment of Inertia
	$r_o^2 = \bar{r}_c^2 + d^2$	Polar radius of gyration
	$r^2 = \bar{r}^2 + d^2$	Radius of gyration

* I can be negative again if the area is negative (a hole or subtraction).

** If \bar{I} is not given in a chart, but \bar{x} & \bar{y} are: YOU MUST CALCULATE \bar{I} WITH $\bar{I} = I - Ad^2$

Composite Areas:

$$I = \sum \bar{I} + \sum Ad^2 \quad \text{where} \quad \bar{I} \text{ is the moment of inertia about the centroid of the component area}$$

d is the distance from the centroid of the component area to the centroid of the composite area (ie. $d_y = \hat{y} - \bar{y}$)

Basic Steps

1. Draw a reference origin.
2. Divide the area into basic shapes
3. Label the basic shapes (components)
4. Draw a table with headers of
 $Component, Area, \bar{x}, \bar{x}A, \bar{y}, \bar{y}A, \bar{I}_x, d_y, Ad_y^2, \bar{I}_y, d_x, Ad_x^2$
5. Fill in the table values needed to calculate \hat{x} and \hat{y} for the composite
6. Fill in the rest of the table values.
7. Sum the moment of inertia (\bar{I} 's) and Ad^2 columns and add together.

Geometric Properties of Areas

Rectangle		$\bar{I}_{x'} = \frac{1}{12}bh^3$ $\bar{I}_{y'} = \frac{1}{12}b^3h$ $I_x = \frac{1}{3}bh^3 \text{ about bottom}$ $I_y = \frac{1}{3}b^3h \text{ left}$ $J_C = \frac{1}{12}bh(b^2 + h^2)$	<p>Area = bh</p> <p>$\bar{x} = b/2$</p> <p>$\bar{y} = h/2$</p>
Triangle		$\bar{I}_{x'} = \frac{1}{36}bh^3$ $I_x = \frac{1}{12}bh^3$ $\bar{I}_{y'} = \frac{1}{36}b^3h$	<p>Area = $bh/2$</p> <p>$\bar{x} = b/3$</p> <p>$\bar{y} = h/3$</p>
Circle		$\bar{I}_x = \bar{I}_y = \frac{1}{4}\pi r^4$ $J_O = \frac{1}{2}\pi r^4$	<p>Area = $\pi r^2 = \pi d^2/4$</p> <p>$\bar{x} = 0$</p> <p>$\bar{y} = 0$</p>
Semicircle		$\bar{I}_x = 0.1098r^4$ $\bar{I}_y = \pi r^4/8$	<p>Area = $\pi r^2/2 = \pi d^2/8$</p> <p>$\bar{x} = 0$</p> <p>$\bar{y} = 4r/3\pi$</p>
Quarter circle		$\bar{I}_x = 0.0549r^4$ $\bar{I}_y = 0.0549r^4$	<p>Area = $\pi r^2/4 = \pi d^2/16$</p> <p>$\bar{x} = 4r/3\pi$</p> <p>$\bar{y} = 4r/3\pi$</p>
Ellipse		$\bar{I}_x = \frac{1}{4}\pi ab^3$ $\bar{I}_y = \frac{1}{4}\pi a^3b$ $J_O = \frac{1}{4}\pi ab(a^2 + b^2)$	<p>Area = πab</p> <p>$\bar{x} = 0$</p> <p>$\bar{y} = 0$</p>
Semiparabolic area		$\bar{I}_x = 16ah^3/175$	<p>Area = $4ah/3$</p> <p>$\bar{x} = 0$</p> <p>$\bar{y} = 3h/5$</p>
Parabolic area		$\bar{I}_y = 4a^3h/15$	
Parabolic spandrel		$\bar{I}_x = 37ah^3/2100$ $\bar{I}_y = a^3h/80$	<p>Area = $ah/3$</p> <p>$\bar{x} = 3a/4$</p> <p>$\bar{y} = 3h/10$</p>

Example 1

Determine the centroidal x and y distances for the composite area shown. Use the lower left corner of the trapezoid as the reference origin.

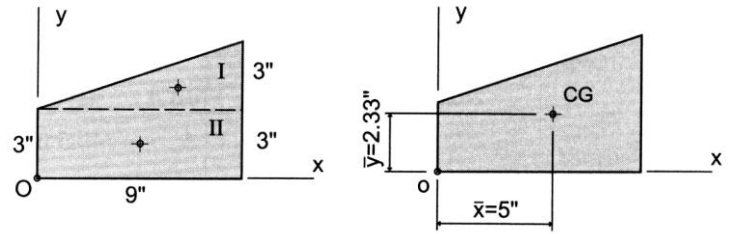

Component	Area (A) ($in.^2$)	\bar{x} ($in.$)	$\bar{x}A$ ($in.^3$)	\bar{y} ($in.$)	$\bar{y}A$ ($in.^3$)
<p>(a)</p>	$\frac{9(3)}{2} = 13.5 in.^2$	6"	81 $in.^3$	4"	54 $in.^3$
<p>(b)</p>	$9(3) = 27 in.^2$	4.5"	121.5 $in.^3$	1.5"	40.5 $in.^3$
	$A = \sum A = 40.5 in.^2$		$\sum \bar{x}A = 202.5 in.^3$		$\sum \bar{y}A = 94.5 in.^3$

$$\hat{x} = \frac{202.5 in.^3}{40.5 in.^2} = 5 in$$

$$\hat{y} = \frac{94.5 in.^3}{40.5 in.^2} = 2.33 in$$

Example 2

An alternate method that can be employed in solving this problem is referred to as the *negative area method*.

A 6" thick concrete wall panel is precast to the dimensions as shown. Using the lower left corner as the reference origin, determine the center of gravity (centroid) of the panel.

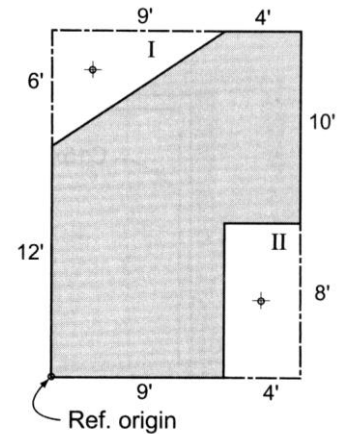

Example 3

Find the moments of inertia ($\hat{x} = 3.05''$, $\hat{y} = 1.05''$).

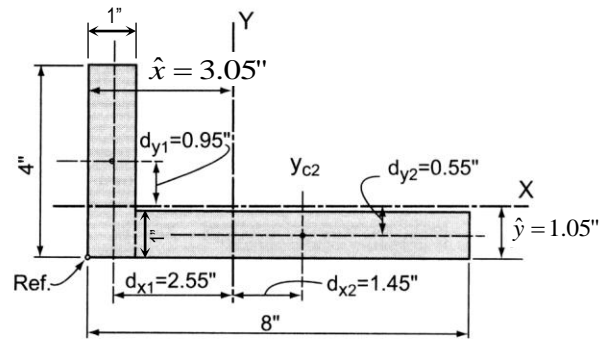

Component	I_{xc} (in. ⁴)	d_y (in.)	Ad_y^2 (in. ⁴)	I_{yc} (in. ⁴)	d_x (in.)	Ad_x^2 (in. ⁴)
	$\frac{(1)(4)^3}{12} = 5.33$	0.95	3.61	$\frac{(4)(1)^3}{12} = 0.33$	2.55	26.01
	$\frac{(7)(1)^3}{12} = 0.58$	0.55	2.12	$\frac{(1)(7)^3}{12} = 28.58$	1.45	14.72
	$\sum I_{xc} = 5.91$		$\sum Ad_y^2 = 5.73$	$\sum I_{yc} = 28.91$		$\sum Ad_x^2 = 40.73$

Example 4

Determine the I about the centroidal x -axis.

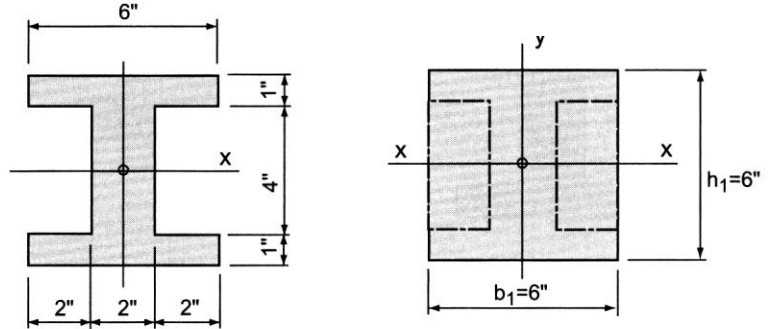

Example 5

Determine the moments of inertia about the centroid of the shape.

Solution:

There is no reference origin suggested in figure (a), so the bottom left corner is good.

In figure (b) area A will be a complete rectangle, while areas C and A are "holes" with negative area and negative moment of inertias.

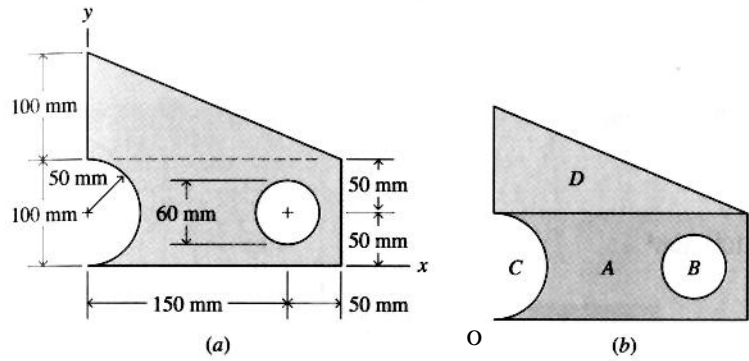

Area A = 200 mm x 100 mm = 20000 mm²

$I_x = (200 \text{ mm})(100 \text{ mm})^3/12 = 16.667 \times 10^6 \text{ mm}^4$
 $I_y = (200 \text{ mm})^3(100 \text{ mm})/12 = 66.667 \times 10^6 \text{ mm}^4$

Area B = $-\pi(30 \text{ mm})^2 = -2827.4 \text{ mm}^2$

$I_x = I_y = -\pi (30 \text{ mm})^4/4 = -0.636 \times 10^6 \text{ mm}^4$

Area C = $-1/2\pi(50 \text{ mm})^2 = 3927.0 \text{ mm}^2$

$I_x = -\pi (50 \text{ mm})^4/8 = -2.454 \times 10^6 \text{ mm}^4$
 $I_y = -0.1098(50 \text{ mm})^4 = -0.686 \times 10^6 \text{ mm}^4$

Area D = 100 mm x 200 mm x 1/2 = 10000 mm²

$I_x = (200 \text{ mm})(100 \text{ mm})^3/36 = 5.556 \times 10^6 \text{ mm}^4$
 $I_y = (200 \text{ mm})^3(100 \text{ mm})/36 = 22.222 \times 10^6 \text{ mm}^4$

shape	A (mm ²)	\bar{x} (mm)	$\bar{x}A$ (mm ³)	\bar{y} (mm)	$\bar{y}A$ (mm ³)
A	20000	100	2000000	50	1000000
B	-2827.43	150	-424115	50	-141372
C	-3926.99	21.22066	-83333.3	50	-196350
D	10000	66.66667	666666.7	133.3333	1333333
	23245.58		2159218		1995612

$\hat{x} = \frac{2159218 \text{ mm}^3}{23245.58 \text{ mm}^2} = 92.9 \text{ mm}$
 $\hat{y} = \frac{1995612 \text{ mm}^3}{23245.58 \text{ mm}^2} = 85.8 \text{ mm}$

shape	I_x (mm ⁴)	d_y (mm)	Ad_y^2 (mm ⁴)	I_y (mm ⁴)	d_x (mm)	Ad_x^2 (mm ⁴)
A	16666667	35.8	25632800	66666667	-7.1	1008200
B	-636173	35.8	-3623751.73	-636173	-57.1	-9218592.093
C	-2454369	35.8	-5032988.51	-686250	71.67934	-20176595.22
D	5555556	-47.5333	22594177.8	22222222	26.23333	6881876.029
	19131680		39570237.5	87566466		-21505111.29

So, $I_x = 19131680 + 39570237.5 = 58701918 = 58.7 \times 10^6 \text{ mm}^4$

$I_x = 87566466 + -21505111.3 = 43572025 = 66.1 \times 10^6 \text{ mm}^4$

Example 6

Locate the centroidal x and y axes for the cross-section shown. Use the reference origin indicated and assume that the steel plate is centered over the flange of the wide-flange section. Compute the I_x and I_y about the major centroidal axes.

