

Mechanics of Materials

Notation:

<p>a = acceleration</p> <p>A = area (net = with holes, bearing = in contact, etc...)</p> <p>ASD = allowable stress design</p> <p>d = diameter of a hole</p> <p>d = calculus symbol for differentiation</p> <p>e = change in length</p> <p>E = modulus of elasticity or Young's modulus</p> <p>f = symbol for stress</p> <p>f = physics symbol for force</p> <p>$f_{allowable}$ = allowable stress</p> <p>f_v = shear stress</p> <p>f_p = bearing stress (see P)</p> <p>$F_{allowed.}$ = allowable stress</p> <p>$F.S.$ = factor of safety</p> <p>g = acceleration due to gravity</p> <p>GPa = giga Pascals (10^9 Pa)</p> <p>kPa = kilopascals or 1 kN/m^2</p> <p>ksi = kips per square inch</p> <p>L = length</p> <p>$LRFD$ = load and resistance factor design</p> <p>m = mass</p> <p>Mpa = megapascals or 10^6 N/m^2 or 1 N/mm^2</p> <p>psi = pounds per square inch</p> <p>psf = pounds per square foot</p> <p>P = name for axial force vector</p> <p>P' = name for internal axial force vector</p> <p>Pa = Pascal (N/m^2)</p> <p>R = name for reaction force vector</p> <p>R = name for design quantity (force or moment) for LRFD, ex. R_L, R_D, or R_n</p>	<p>s = normal strain</p> <p>s = length traveled of a particle</p> <p>t = thickness</p> <p>v = velocity</p> <p>ν = Poisson's ratio</p> <p>W = force due to a weight</p> <p>x = horizontal dimension</p> <p>y = vertical dimension</p> <p>α = coefficient of thermal expansion for a material</p> <p>ϵ = strain</p> <p>ϵ_t = thermal strain (no units)</p> <p>δ = elongation or length change</p> <p>δ_P = elongation due to axial load</p> <p>δ_{restr} = restrained length change</p> <p>δ_T = elongation due or length change due to temperature</p> <p>ΔT = change in temperature</p> <p>ϕ = angle of twist</p> <p>ϕ = resistance factor for LRFD</p> <p>ϕ = diameter symbol</p> <p>μ = lateral strain ratio or Poisson's ratio</p> <p>μ = symbol for micron</p> <p>γ = shear strain</p> <p>γ_D = dead load factor for LRFD</p> <p>γ_L = live load factor for LRFD</p> <p>θ = angle of principle stress</p> <p>ρ = radial distance</p> <p>σ = engineering symbol for normal stress</p> <p>τ = engineering symbol for shearing stress</p>
--	---

Mechanics of Materials is a basic engineering science that deals with the relation between externally applied load and its effect on deformable bodies. The main purpose of Mechanics of Materials is to answer the question of which requirements have to be met to assure STRENGTH, RIGIDITY, AND STABILITY of engineering structures.

To solve a problem in Mechanics of Materials, one has to consider **THREE ASPECTS OF THE PROBLEM**:

1. **STATICS**: equilibrium of external forces, internal forces, stresses
2. **GEOMETRY**: deformations and conditions of geometric fit, strains
3. **MATERIAL PROPERTIES**: stress-strain relationship for each material, obtained from material testing.

- **STRESS** – The intensity of a force acting over an **area**

Normal Stress (or Direct Stress)

Stress that acts along an *axis* of a member; can be internal or external; can be compressive or tensile.

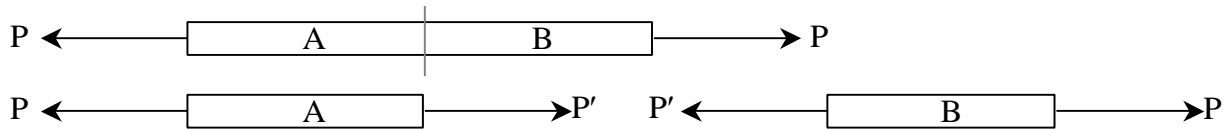

$$f = \sigma = \frac{P}{A_{net}} \quad \text{Strength condition: } f = \frac{P}{A_{net}} < f_{allowable} \text{ or } F_{allowed}$$

Shear Stress (or Direct Shear Stress)

Stress that acts perpendicular to an *axis or length* of a member, or that is **parallel** to the cross section is called shear stress.

Shear stress cannot be assumed to be uniform, so we refer to *average shearing stress*.

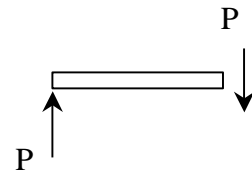

$$f_v = \tau = \frac{P}{A_{net}} \quad \text{Strength condition: } f_v = \frac{P}{A_{net}} < \tau_{allowable} \text{ or } F_{allowed}$$

Shear Stress in Beams

A stress that acts transversely to the cross section, or along the beam length. It happens when there are vertical loads on a horizontal beam, and is larger than direct shear stress from the internal vertical force over the cross section.

Bearing Stress

A compressive normal stress acting *between two bodies*.

$$f_p = \frac{P}{A_{bearing}}$$

Bending Stress in Beams

A normal stress caused by bending; can be compressive or tensile.

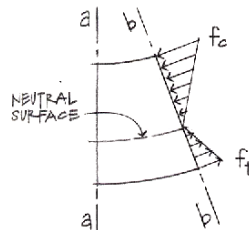
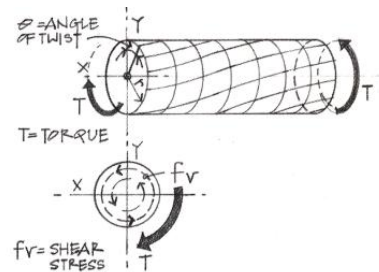
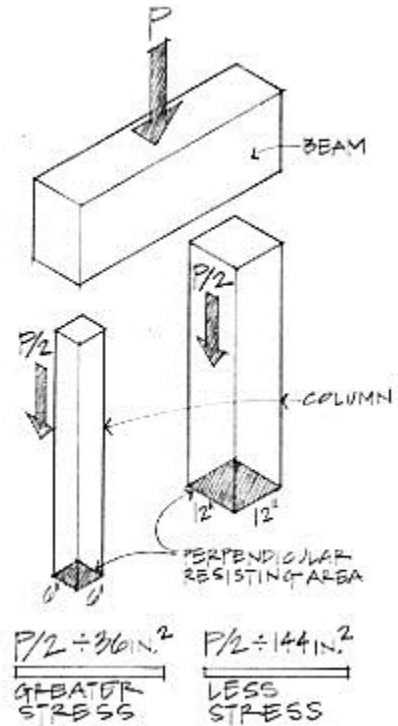

Figure 8.8 Bending stresses on section b-b.

Torsional Stress

A shear stress caused by torsion (moment around the axis).



Bolts in Shear and Bearing

Single shear - forces cause only one shear “drop” across the bolt.

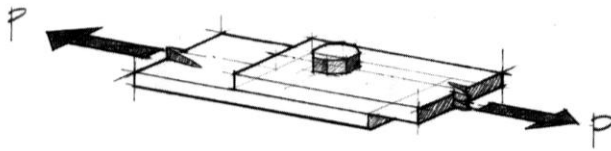

(a) Two steel plates bolted using one bolt.

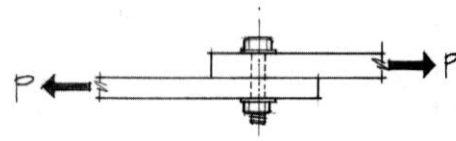

(b) Elevation showing the bolt in shear.

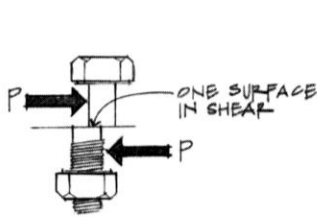

(c)

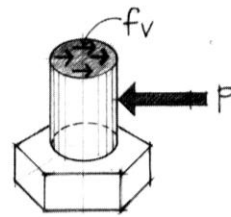

(d)

f_v = Average shear stress through bolt cross section

A = Bolt cross-sectional area

$$f_v = \frac{P}{A}$$

Figure 5.11 A bolted connection—single shear.

Double shear - forces cause two shear changes across the bolt.

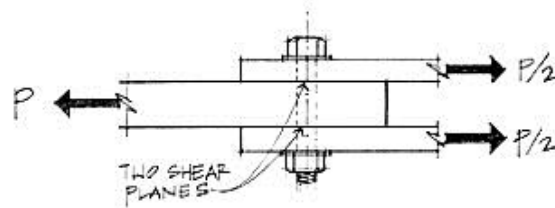

$$f_v = \frac{P}{2A}$$

(two shear planes)

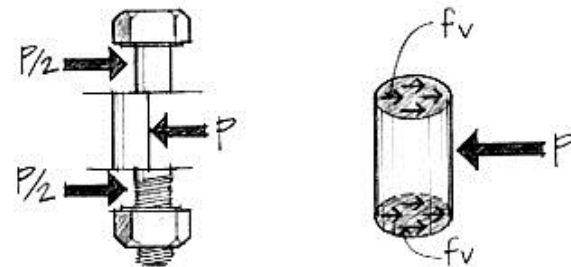

Free-body diagram of middle section of the bolt in shear.

Figure 5.12 A bolted connection in double shear.

Bearing of a bolt on a bolt hole – The bearing surface can be represented by *projecting* the cross section of the bolt hole on a plane (into a rectangle).

$$f_p = \frac{P}{A} = \frac{P}{td}$$

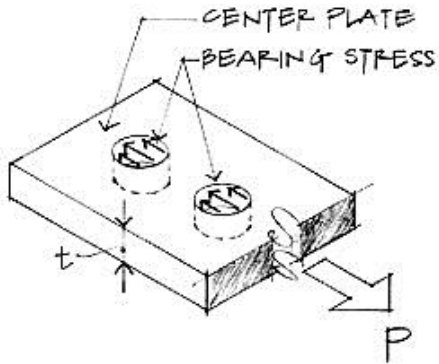

Bearing stress on plate.

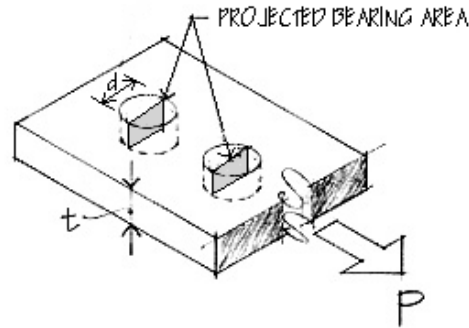

- **STRAIN** –The relative change in geometry (length, angle, etc.) with respect to the original geometry. *Deformation* is the change in the size or shape of a structural member under loading. It can also occur due to heating or cooling of a material.

Normal Strain

In an axially loaded member, normal strain, s (or ϵ) is the change in the length, e (or δ) with respect to the original length, L .

$$s = \frac{e}{L} \quad \text{or} \quad \epsilon = \frac{\delta}{L}$$

It is UNITLESS, but may be called strain or microstrain (μ).

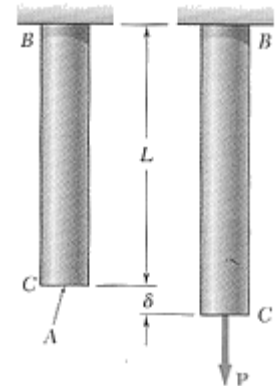

Shearing Strain

In a member loaded with shear forces, shear strain, γ is the change in the sheared side, δ_s with respect to the original height, L . For small angles: $\tan \phi \cong \phi$.

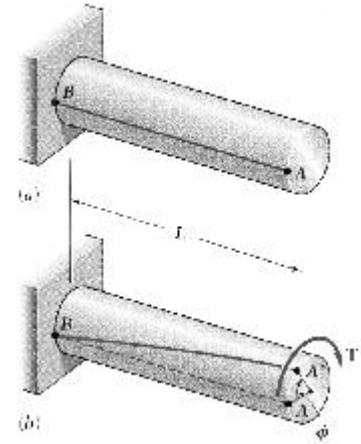
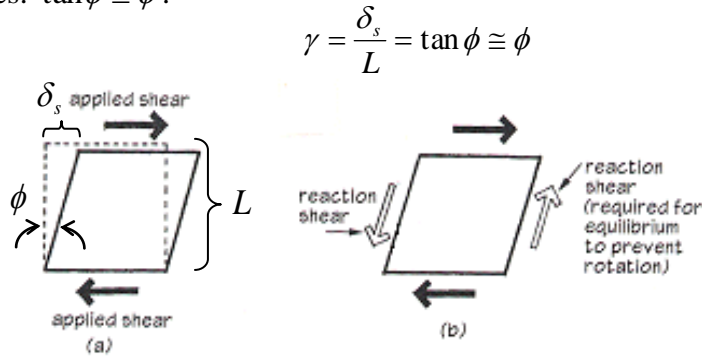

In a member subjected to twisting, the shearing strain is a measure of the angle of twist with respect to the length and distance from the center, ρ :

$$\gamma = \frac{\rho\phi}{L}$$

Testing of Load vs. Strain

Behavior of materials can be measured by recording deformation with respect to the size of the load. For members with constant cross section area, we can plot stress vs. strain.

BRITTLE MATERIALS - ceramics, glass, stone, cast iron; show abrupt fracture at small strains.

DUCTILE MATERIALS – plastics, steel; show a yield point and large strains (considered *plastic*) and “necking” (give warning of failure)

SEMI-BRITTLE MATERIALS – concrete; show no real yield point, small strains, but have some “strain-hardening”.

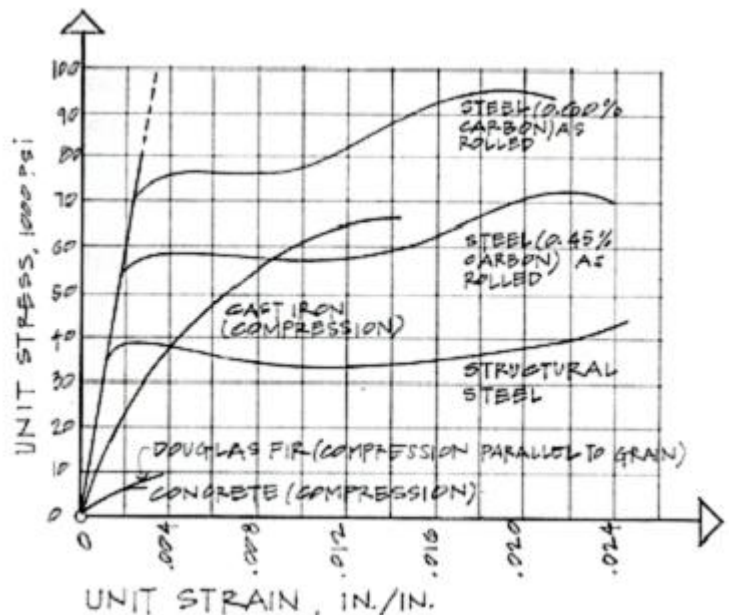

Linear-Elastic Behavior

In the straight portion of the stress-strain diagram, the materials are *elastic*, which means if they are loaded and unloaded no permanent **deformation** occurs.

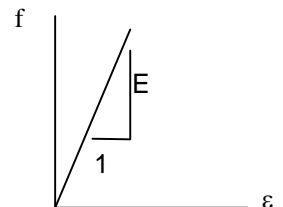

True Stress & Engineering Stress

True stress takes into account that the area of the cross section changes with loading. Engineering stress uses the original area of the cross section.

Hooke's Law – Modulus of Elasticity

In the linear-elastic range, the slope of the stress-strain diagram is *constant*, and has a value of E , called Modulus of Elasticity or Young's Modulus.

$$f = E \cdot s \quad \text{or} \quad f = E \cdot \varepsilon$$

Isotropic Materials – have the **same** E with any direction of loading.

Anisotropic Materials – have **different** E 's with the direction of loading.

Orthotropic Materials – have **directionally based** E 's

Table D-1 Elastic moduli of selected materials

Material	Modulus of elasticity E		Shear modulus G		Poisson's ratio ν
	10^6 psi	GPa	10^6 psi	GPa	
Aluminum	10	70	3.8	26	0.33
Aluminum alloys	10–12	70–80	3.8–4.4	26–30	0.33
2014-T6	10.6	73	4	28	0.33
6061-T6	10	70	3.8	26	0.33
7075-T6	10.4	72	3.9	27	0.33
Brick (compression)	1.5–3.5	10–24			
Cast iron	12–25	80–170	4.5–10	31–69	0.2–0.3
Gray cast iron	14	97	5.6	39	0.25
Concrete (compression)	2.6–4.4	18–30			0.1–0.2
Copper	17	115	6.2	43	0.35
Copper alloys	14–18	96–120	5.2–6.8	36–47	0.33–0.35
Brass	14–16	96–110	5.2–6	36–41	0.34
80% Cu, 20% Zn	15	100	5.5	38	0.33
Naval brass	15	100	5.5	38	0.33
Bronze	14–17	96–120	5.2–6.3	36–44	0.34
Manganese bronze	15	100	5.6	39	0.35
Glass	7–12	50–80	2.9–5	20–33	0.20–0.27
Magnesium	5.8	40	2.2	15	0.34
Nickel	30	210	11.4	80	0.31
Nylon	0.3–0.4	2–3			0.4
Rubber	0.0001–0.0006	0.001–0.004	0.00004–0.0002	0.0003–0.0014	0.44–0.50
Steel	28–32	190–220	10.8–12.3	75–85	0.28–0.30
Stone (compression)					
Granite	6–10	40–70			0.2–0.3
Marble	7–14	50–100			0.2–0.3
Titanium	16	110	5.8	40	0.33
Titanium alloys	15–18	100–124	5.6–6.8	39–47	0.33
Tungsten	52	360	22	150	0.2
Wood (bending)					
Ash	1.5–1.6	10–11			
Oak	1.6–1.8	11–12			
Southern pine	1.6–2	11–14			
Wrought iron	28	190	10.9	75	0.3

Plastic Behavior & Fatigue

Permanent deformations happen outside the linear-elastic range and are called *plastic* deformations. Fatigue is damage caused by reversal of loading.

- The proportional limit (at the end of the **elastic** range) is the greatest stress valid using Hooke's law.
- The elastic limit is the maximum stress that can be applied before permanent deformation would appear upon unloading.
- The yield point (at the **yield stress**) is where a ductile material continues to elongate without an increase of load. (May not be well defined on the stress-strain plot.)
- The ultimate strength is the largest stress a material will see before rupturing, also called the *tensile strength*.
- The rupture strength is the stress at the point of rupture or failure. It may not coincide with the ultimate strength in ductile materials. In brittle materials, it will be the same as the ultimate strength.
- The fatigue strength is the stress at failure when a member is subjected to reverse cycles of stress (up & down or compression & tension). This can happen at much lower values than the ultimate strength of a material.
- Toughness of a material is how much work (a combination of stress and strain) is used for fracture. It is the area under the stress-strain curve.

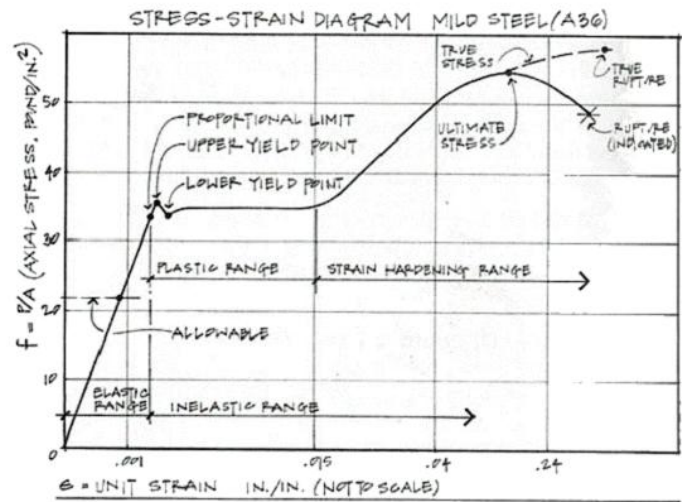

Concrete does not respond well to tension and is tested in compression. The strength at crushing is called the *compression strength*.

Materials that have time dependent elongations when loaded are said to have *creep*. Concrete and wood experience creep. Concrete also has the property of shrinking over time.

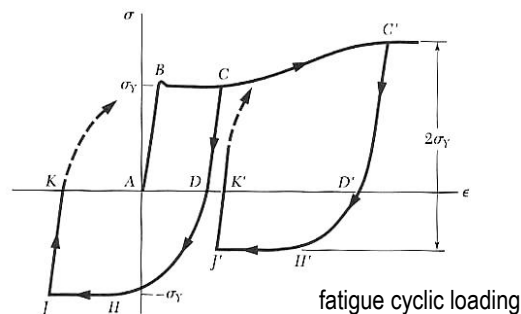
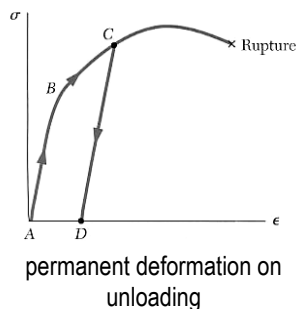

Poisson's Ratio

For an isotropic material that is homogeneous, the properties are the same for the cross section:

$$\epsilon_y = \epsilon_z$$

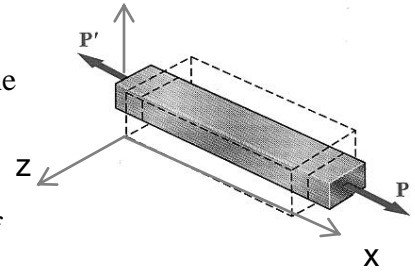

There exists a linear relationship while in the linear-elastic range of the material between *longitudinal strain* and *lateral strain*:

$$\mu = -\frac{\text{lateral strain}}{\text{axial strain}} = -\frac{\epsilon_y}{\epsilon_x} = -\frac{\epsilon_z}{\epsilon_x} \quad \epsilon_y = \epsilon_z = -\frac{\mu f_x}{E}$$

Positive strain results from an increase in length with respect to overall length.

Negative strain results from a decrease in length with respect to overall length.

μ is the Poisson's ratio and has a value between 0 and 1/2, depending on the material.

Relation of Stress to Strain

$$f = \frac{P}{A}; \quad \epsilon = \frac{\delta}{L} \quad \text{and} \quad E = \frac{f}{\epsilon} \quad \text{so} \quad E = \frac{P/A}{\delta/L} \quad \text{which rearranges to:} \quad \delta = \frac{PL}{AE} \quad \text{or} \quad e = \frac{PL}{AE}$$

Orthotropic Materials

One class of non-isotropic materials is *orthotropic materials* that have directionally based values of modulus of elasticity and Poisson's ratio (E, μ).

Ex: plywood, laminates, fiber reinforced polymers with direction fibers

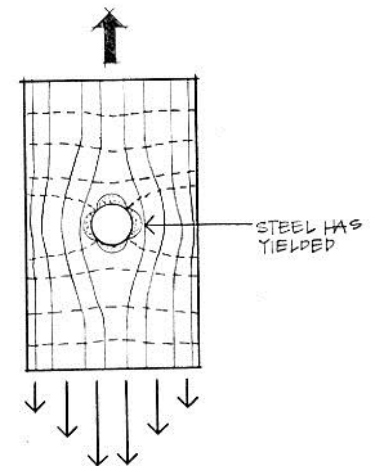
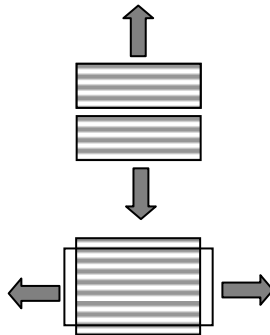
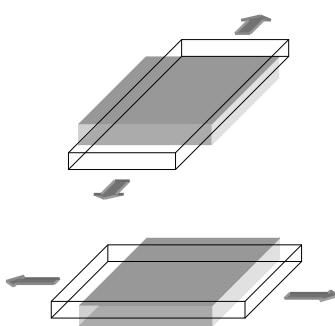
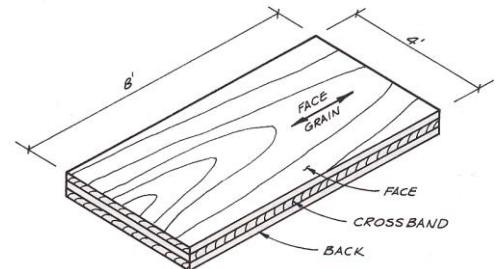

Figure 5.35 Stress trajectories around a hole.

Stress Concentrations

In some sudden changes of cross section, the stress concentration changes (and is why we used *average* normal stress). Examples are sharp notches, or holes or corners.

(Think about airplane window shapes...)

Maximum Stress

When both normal stress and shear stress occur in a structural member, the *maximum stresses can occur at some other planes* (angle of θ).

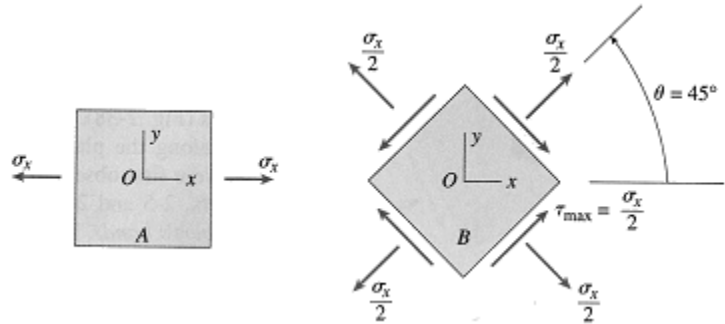

Maximum Normal Stress happens when $\theta = 0^\circ$ AND

Maximum Shearing Stress happens when $\theta = 45^\circ$ with only normal stress in the x direction.

Thermal Strains

Physical restraints limit deformations to be the same, or sum to **zero**, or to be proportional with respect to the rotation of a rigid body.

We know axial stress relates to axial strain: $e = \delta = \frac{PL}{AE}$ which relates e or δ to P .

Deformations can be caused by the *material* reacting to a change in energy with temperature. In general (there are some exceptions):

- Solid materials can **contract** with a decrease in temperature.
- Solid materials can **expand** with an increase in temperature.

The change in length per unit temperature change is the *coefficient of thermal expansion*, α . It

has units of $/^\circ F$ or $/^\circ C$ and the deformation is related by: $\delta_T = \alpha(\Delta T)L$

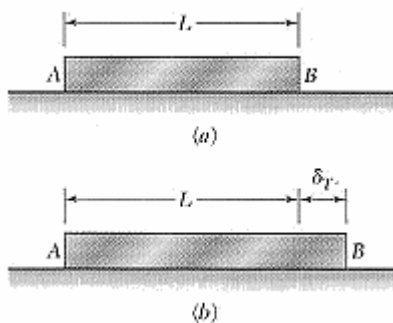

Thermal Strain: $\epsilon_T = \alpha\Delta T$

Coefficient of Thermal Expansion

Material	Coefficients (α) [in./in./°F]	Coefficients (α) [mm/mm/°C]
Wood	3.0×10^{-6}	5.4×10^{-6}
Glass	4.4×10^{-6}	8.0×10^{-6}
Concrete	5.5×10^{-6}	9.9×10^{-6}
Cast Iron	5.9×10^{-6}	10.6×10^{-6}
Steel	6.5×10^{-6}	11.7×10^{-6}
Wrought Iron	6.7×10^{-6}	12.0×10^{-6}
Copper	9.3×10^{-6}	16.8×10^{-6}
Bronze	10.1×10^{-6}	18.1×10^{-6}
Brass	10.4×10^{-6}	18.8×10^{-6}
Aluminum	12.8×10^{-6}	23.1×10^{-6}

There is **no stress** associated with the length change with free movement, BUT if there are restraints, thermal deformations or strains *can cause internal forces and stresses*.

How A Restrained Bar Feels with Thermal Strain

1. Bar pushes on supports because the material needs to expand with an increase in temperature.
2. Supports push *back*.

Bar is restrained, can't move and the reaction causes internal stress.

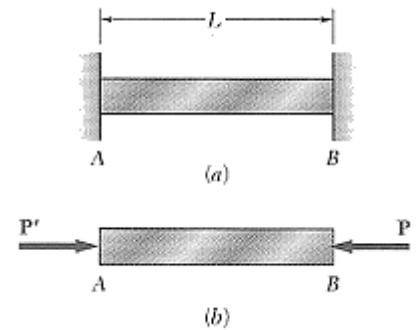

Superposition Method

If we want to solve a statically indeterminate problem that has extra support forces, we can:

- Remove a support or supports that *makes the problem look statically determinate*
- Replace it with a reaction and treat it like it is an applied force
- Impose the geometry restrictions that the support imposes

For Example:

$$\delta_T = \alpha(\Delta T)L \quad \delta_p = -\frac{PL}{AE}$$

$$\delta_p + \delta_T = 0 \quad -\frac{PL}{AE} + \alpha(\Delta T)L = 0$$

$$P = \alpha(\Delta T)L \frac{AE}{L} = \alpha(\Delta T)AE \quad f = -\frac{P}{A} = -\alpha(\Delta T)E$$

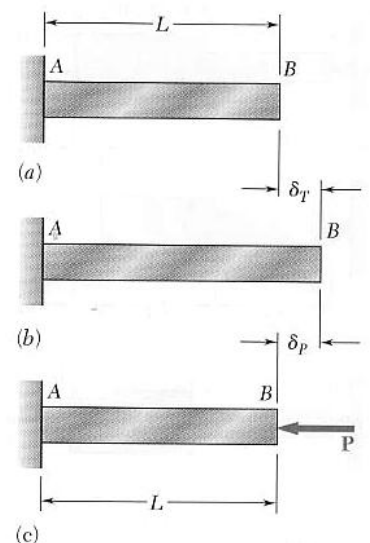

Dynamics

The study of bodies in motion due to forces and accelerations is called dynamics, in which time is an important consideration.

A particle or body can have a displacement that is a function of time. The velocity is the *change in displacement* as a function of time. The acceleration is the *change in velocity* as a function of time.

Calculus is helpful to work backward from acceleration to the distance traveled at a certain time.

Because $a = \frac{dv}{dt} = \frac{d^2s}{dt^2}$, $s(t) = v(0)t + \frac{1}{2}at^2$

Acceleration, from gravity or earthquakes, when acting on a mass, results in a force:

$$f = ma \quad \text{and weight due to gravity on a mass is:} \quad W = mg$$

Work is defined as the product of the force by the distance traveled. *Potential energy* is the stored energy (like from the height of water in an elevated tank). *Kinetic energy* is from bodies in motion. *Conservation of energy* is the principal that work can change form, but not diminish or increase, or “work in” = “work out”.

Harmonic motion is a cyclic motion, meaning it swings one way then back the other with a certain *amplitude* or height, and *period or frequency* (time per cycle or number of cycles per unit time). Buildings and massed structures have a fundamental period, which is extremely important for their behavior under earthquake motion. *Resonance* causes the harmonic motion amplitude to be enhanced or magnified, which is a serious problem in structures.

Allowable Stress Design (ASD) and Factor of Safety (F.S.) (aka safety factor)

There are uncertainties in material strengths: $F.S. = \frac{\text{ultimate load}}{\text{allowable load}} = \frac{\text{ultimate stress}}{\text{allowable stress}}$

Allowable stress design determines the allowable stress by: $\text{allowable stress} = \frac{\text{ultimate stress}}{F.S.}$

Load and Resistance Factor Design – LRFD

There are uncertainties in material strengths *and* in structural loadings.

$$R_u = \gamma_D R_D + \gamma_L R_L \leq \phi R_n$$

where γ = load factor for Dead and Live loads

R = load (dead or live)

ϕ = resistance factor

R_n = ultimate load (nominal capacity)

Example 1 (pg 58)

*Example 3**. A running track in a gymnasium is hung from the roof trusses by 9.84 ft [3 m] long steel rods, each of which supports a tensile load of 11,200 lb [49,818 N]. The round rods have a diameter of 7/8 in. [22.23 mm] with the ends *upset*, that is, made larger by forging. This upset allows the full cross-sectional area of the rod (0.601 in.^2) [388 mm^2] to be utilized; otherwise the cutting of the threads will reduce the cross section of the rod. Investigate this design to determine whether it is safe. Also, determine the elongation of the steel rods when the load at capacity is applied.

Example 2

A W8x67 steel beam, 20 ft. in length, is rigidly attached at one end of a concrete wall. If a gap of 0.010 in. exists at the opposite end when the temperature is 45°F, what results when the temperature rises to 95°F?

ALSO: If the beam is anchored to a concrete slab, and the steel sees a temperature change of 50° F while the concrete only sees a change of 30° F, determine the compressive stress in the beam.

$$\begin{aligned} \alpha_c &= 5.5 \times 10^{-6} / ^\circ \text{F} & E_c &= 3 \times 10^6 \text{ psi} \\ \alpha_s &= 6.5 \times 10^{-6} / ^\circ \text{F} & E_s &= 29 \times 10^6 \text{ psi} \end{aligned}$$

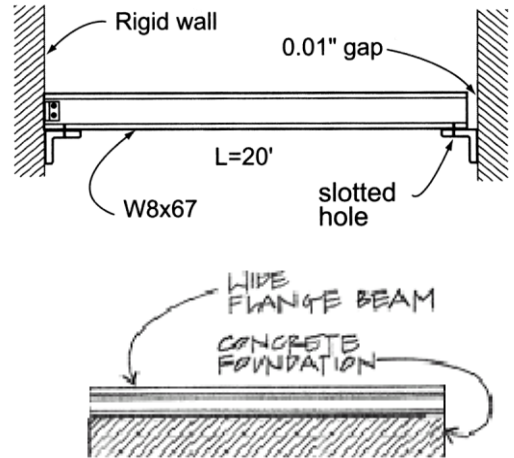
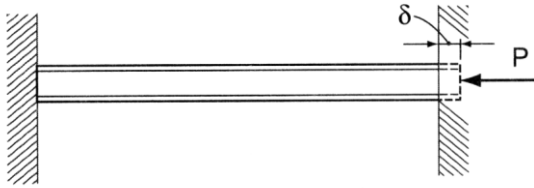

Example 3

A short concrete column measuring 12 in. square is reinforced with four #8 bars ($A_s = 4 \times 0.79 \text{ in.}^2 = 3.14 \text{ in.}^2$) and supports an axial load of 250k. Steel bearing plates are used top and bottom to ensure equal deformations of steel and concrete. Calculate the stress developed in each material if:

$$E_c = 3 \times 10^6 \text{ psi and}$$

$$E_s = 29 \times 10^6 \text{ psi}$$

Solution:

From equilibrium:

$$[\Sigma F_y = 0] - 250 \text{ k} + f_s A_s + f_c A_c = 0$$

$$A_s = 3.14 \text{ in.}^2$$

$$A_c = (12'' \times 12'') - 3.14 \text{ in.}^2 \cong 141 \text{ in.}^2$$

$$3.14 f_s + 141 f_c = 250 \text{ k}$$

From the deformation relationship:

$$\delta_s = \delta_c; L_s = L_c$$

$$\therefore \frac{\delta_s}{L} = \frac{\delta_c}{L}$$

and

$$\epsilon_s = \epsilon_c$$

Since

$$E = \frac{f}{\epsilon}$$

and

$$\frac{f_s}{E_s} = \frac{f_c}{E_c}$$

$$f_s = f_c \frac{E_s}{E_c} = \frac{29 \times 10^3 (f_c)}{3 \times 10^3} = 9.67 f_c$$

Substituting into the equilibrium equation:

$$3.14 (9.67 f_c) + 141 f_c = 250$$

$$30.4 f_c + 141 f_c = 250$$

$$171.4 f_c = 250$$

$$f_c = 1.46 \text{ ksi}$$

$$\therefore f_s = 9.67 (1.46) \text{ ksi}$$

$$f_s = 14.1 \text{ ksi}$$

