

ARCH 614: Practice Quiz 10

*Note: No aids are allowed for part 1. One side of a letter sized paper with notes is allowed during part 2, along with a silent, **non-programmable** calculator. There are reference charts on pages 2-3 for part 2.*

Clearly show your work and answer.

Part 1) *Worth 5 points*
 (conceptual questions)

Part 2) *Worth 45 points*

(NOTE: The member size, load magnitudes, reinforcement, and materials can and will be changed for the quiz! The beam supports will not change.)

A 28 ft simply supported reinforced concrete beam is 12 in. wide by 22 in. deep with 6-#6 bars with 3000 psi concrete (150 lb/ft^3) and Grade 50 reinforcement ($f_y = 50 \text{ ksi}$). The beam has distributed dead load of 125 lb/ft, a self weight, and live load of 750 lb/ft.

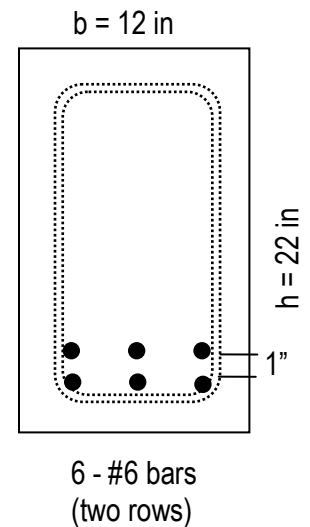

- a) Determine if the beam is adequate for flexure, when $d = 18.875 \text{ in}$, and meets reinforcement requirements.
- b) Determine the length which shear stirrups are required for strength and the length required for crack control with the corresponding spacings using (2-legged) #3 U stirrups of grade 40 steel ($f_y = 40 \text{ ksi}$).

Answers – Not provided on actual quiz!

- a) $M_u = 165 \text{ k-ft} \leq \phi M_n = 166 \text{ k-ft}$ and $\rho_{\min} < 0.012 < \rho_{\max(\text{at strain of } 0.005)}$ \therefore OK
- b) $V_{u@d} = 20.9 \text{ k}$, $\phi V_c = 18.6 \text{ k}$. Stirrups required for strength to 2.92 ft and for crack control to 8.45 feet from the beam end with $s = 9 \text{ in}$ ($s_{\text{req'd}} \leq 54 \text{ in}$ for strength).

Disclaimer: Answers have NOT been painstakingly researched.

REFERENCE CHARTS FOR QUIZ 10

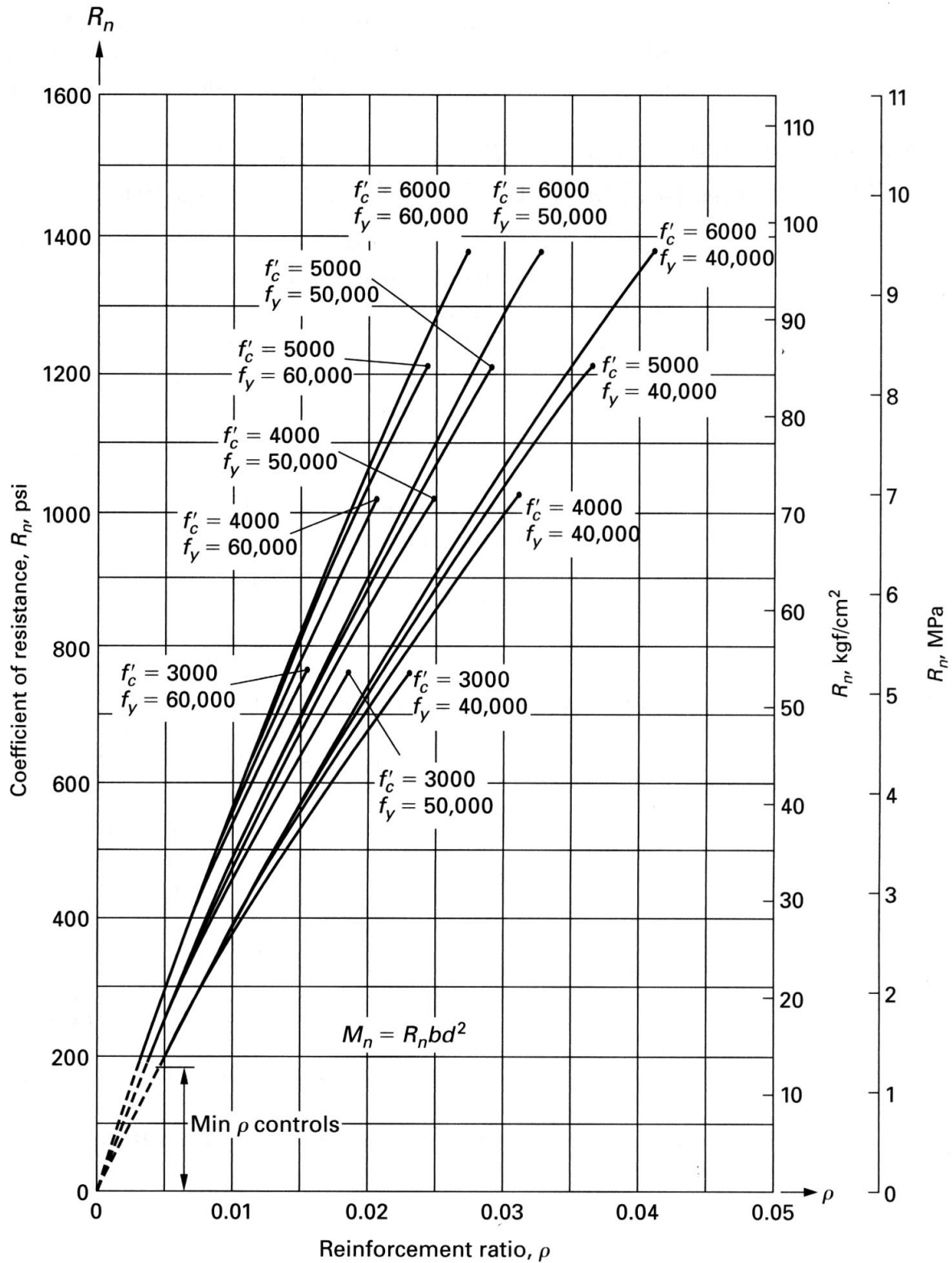

Figure 3.8.1 Strength curves (R_n vs ρ) for singly reinforced rectangular sections. Upper limit of curves is at ρ_{max} . (tensile strain of 0.004)

REFERENCE CHARTS FOR QUIZ 10

Maximum Reinforcement Ratio ρ for Singly Reinforced Rectangular Beams
(tensile strain = 0.005) for which ϕ is permitted to be 0.9

f_y	$f'_c = 3000$ psi	$f'_c = 3500$ psi	$f'_c = 4000$ psi	$f'_c = 5000$ psi	$f'_c = 6000$ psi
	$\beta_1 = 0.85$	$\beta_1 = 0.85$	$\beta_1 = 0.85$	$\beta_1 = 0.80$	$\beta_1 = 0.75$
40,000 psi	0.0203	0.0237	0.0271	0.0319	0.0359
50,000 psi	0.0163	0.0190	0.0217	0.0255	0.0287
60,000 psi	0.0135	0.0158	0.0181	0.0213	0.0239

f_y	$f'_c = 20$ MPa	$f'_c = 25$ MPa	$f'_c = 30$ MPa	$f'_c = 35$ MPa	$f'_c = 40$ MPa
	$\beta_1 = 0.85$	$\beta_1 = 0.85$	$\beta_1 = 0.85$	$\beta_1 = 0.81$	$\beta_1 = 0.77$
300 MPa	0.0181	0.0226	0.0271	0.0301	0.0327
350 MPa	0.0155	0.0194	0.0232	0.0258	0.0281
400 MPa	0.0135	0.0169	0.0203	0.0226	0.0245
500 MPa	0.0108	0.0135	0.0163	0.0181	0.0196

STEEL REINFORCEMENT INFORMATION

Table 3.7.1

Total Areas for Various Numbers of Reinforcing Bars

Bar Size	Nominal Diameter (in.)	Weight (lb/ft)	Number of Bars									
			1	2	3	4	5	6	7	8	9	10
#3	0.375	0.376	0.11	0.22	0.33	0.44	0.55	0.66	0.77	0.88	0.99	1.10
#4	0.500	0.668	0.20	0.40	0.60	0.80	1.00	1.20	1.40	1.60	1.80	2.00
#5	0.625	1.043	0.31	0.62	0.93	1.24	1.55	1.86	2.17	2.48	2.79	3.10
#6	0.750	1.502	0.44	0.88	1.32	1.76	2.20	2.64	3.08	3.52	3.96	4.40
#7	0.875	2.044	0.60	1.20	1.80	2.40	3.00	3.60	4.20	4.80	5.40	6.00
#8	1.000	2.670	0.79	1.58	2.37	3.16	3.95	4.74	5.53	6.32	7.11	7.90
#9	1.128	3.400	1.00	2.00	3.00	4.00	5.00	6.00	7.00	8.00	9.00	10.00
#10	1.270	4.303	1.27	2.54	3.81	5.08	6.35	7.62	8.89	10.16	11.43	12.70
#11	1.410	5.313	1.56	3.12	4.68	6.24	7.80	9.36	10.92	12.48	14.04	15.60
#14 ^a	1.693	7.65	2.25	4.50	6.75	9.00	11.25	13.50	15.75	18.00	20.25	22.50
#18 ^a	2.257	13.60	4.00	8.00	12.00	16.00	20.00	24.00	28.00	32.00	36.00	40.00

^a #14 and #18 bars are used primarily as column reinforcement and are rarely used in beams.

Table 3-8 ACI Provisions for Shear Design*

		$V_u \leq \frac{\phi V_c}{2}$	$\phi V_c \geq V_u > \frac{\phi V_c}{2}$	$V_u > \phi V_c$
Required area of stirrups, A_v **		none	$\frac{50b_w s}{f_y}$	$\frac{(V_u - \phi V_c)s}{\phi f_y d}$
Stirrup spacing, s	Required	—	$\frac{A_v f_y}{50b_w}$	$\frac{\phi A_v f_y d}{V_u - \phi V_c}$
	Recommended Minimum [†]	—	—	4 in.
	Maximum ^{††} (ACI 11.5.4)	—	$\frac{d}{2}$ or 24 in.	$\frac{d}{2}$ or 24 in. for $(V_u - \phi V_c) \leq \phi 4\sqrt{f'_c} b_w d$ $\frac{d}{4}$ or 12 in. for $(V_u - \phi V_c) > \phi 4\sqrt{f'_c} b_w d$

*Members subjected to shear and flexure only; $\phi V_c = \phi 2\sqrt{f'_c} b_w d$, $\phi = 0.75$ (ACI 11.3.1.1)

** $A_v = 2 \times A_b$ for U stirrups; $f_y \leq 60$ ksi (ACI 11.5.2)

†A practical limit for minimum spacing is $d/4$

††Maximum spacing based on minimum shear reinforcement ($= A_v f_y / 50b_w$) must also be considered (ACI 11.5.5.3).