

**NOTE: Configurations, geometry, units, AND questions can and will be changed on the final exam.**

**ARCH 614. Practice Final Examination**

Note: No aids are allowed for part 1. For part 2, a reference document and any necessary charts will be provided (also posted), and two single sides of letter sized paper with notes are allowed along with a silent, **non-programmable** calculator.

**Part 1)** Worth 10% (conceptual questions)

**Part 2)** Clearly show all your work and record your **final answers in the boxes.**

**Question 1)** Worth 45%

- Solid slabs 5 in.-thick are integrally supported on three beams in a two-story frame. The center to center beam spacing is 25 ft.
- The floor slab has a dead load of 30 lb/ft<sup>2</sup> (not including self weight), and a live load of 50 lb/ft<sup>2</sup>. The roof slab has a dead load of 25 lb/ft<sup>2</sup> (not including self weight) and live load of 20 lb/ft<sup>2</sup>.
- The cross section geometry of the girders which support the beams is shown in Figure 1a. The 12 in. by 20 in. section has 6 #8 bars (two layers), #3 stirrups, and I = 5200 in<sup>4</sup>. The self weight is 233 lb/ft.
- The material is light-weight concrete (140 lb/ft<sup>3</sup>) with E = 3,460 ksi and f<sub>c</sub> = 4,000 psi with grade 60 reinforcement.
- Figure 1b shows the *factored* total loading on a girder in the frame from live, dead, and wind loading.

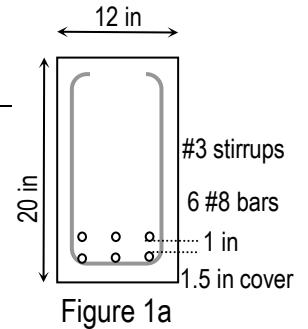

**FIND:**

- If the first floor slab is adequate for shear assuming  $d=4$  in. and the clear span,  $l_n=24$  ft.
- The maximum factored moment,  $M_u$ , and the completed bending moment diagram for the girder (Figure 1b & c).
- If the girder is adequate for bending and reinforcement knowing  $d=16.625$  in..
- If the girder stirrups, which are spaced at 8 in, are adequate when the concrete capacity,  $\phi V_c=18.9$  k, assuming the supports are at A and C.
- The most economical W section of A992 ( $F_y=50$  ksi) steel that could be used for a 29 ft. simply supported beam using the provided Beam Design Moment diagrams if the unbraced length is 11 ft and  $M_u=160$  k-ft at midspan when no self weight has been included (yet).
- The maximum deflection of a W 12 x 53 due to *only* the unfactored load of 14 k at B when ends A and C can be considered fixed.  $E=29 \times 10^3$  ksi,  $I_x=425$  in<sup>4</sup>, and  $I_y=95.8$  in<sup>4</sup>.
- The minimum dimension required for a square footing 18 in. deep when the dead load is 105.7 kips and the live load is 36.5 kips for a soil with  $q_{\text{allowed}}=1800$  lb/ft<sup>2</sup> and a density of 80 lb/ft<sup>3</sup>. Assume normal weight concrete (150 lb/ft<sup>3</sup>).
- The maximum two-way design shear in a 10 ft. square footing having the loads in part g) when the column is 18 in. square and  $d=13.5$  in..

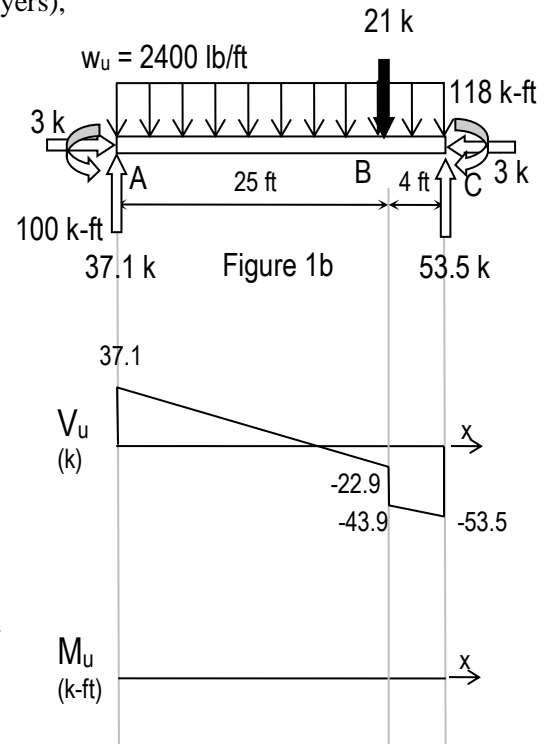

Figure 1c

**Disclaimer: Answers have NOT been painstakingly researched.**

a) yes (2567 lb/unit < $\phi V_c$ )	b)	
c) no ( $M_u \leq 280.3$ k-ft, $\rho \leq \rho_{\text{max}}$ )	d) no ( $S_{\text{req'd}} = 5.3$ in., $S_{\text{max}} = 8.3$ in.)	e)
f) 0.052 in	g)	h) 172.2 k

Question 2) Worth 45%

- A parallel chord truss is shown in the Figure 2a supports dead load and 7 day roof live load. It also has a lateral live load at B of 3 kips. The reactions at the pin and roller supports have been determined to be:  $A_x = -3 \text{ k}$ ,  $A_y = 7.33 \text{ k}$  and  $E = 8.67 \text{ k}$ .
- The truss is constructed with 5 1/8 in. x 12 in. glu-lam lumber for the top and bottom chords having  $E = 1.85 \times 10^6 \text{ psi}$ ,  $\alpha = 3.8 \times 10^{-6} / ^\circ\text{F}$ ,  $F_c = 1700 \text{ psi}$  (no adjustment factors);  $F'_p = 750 \text{ psi}$  (with adjustment factors).
- The top chord is connected to a vertical web member as shown in Figure 2b with 2 - 3/4" A 325-SC bolts (class A), standard bolt holes and 3 in. spacing.
- The truss is constructed with timber 2x's for the diagonal web members as shown in Figure 2b. The material is Douglas Fir Larch No. 1 with  $F'_v = 95 \text{ psi}$  (with adjustment factors.)
- The truss is constructed with a L 4 x 3 x 1/2 in. steel angle welded flush to a 0.75" x 3 in. plate for the vertical web members as shown in Figures 2b and c. All steel is A36 ( $F_y = 36 \text{ ksi}$ ,  $F_u = 58 \text{ ksi}$ ). The weld material is EXX60.

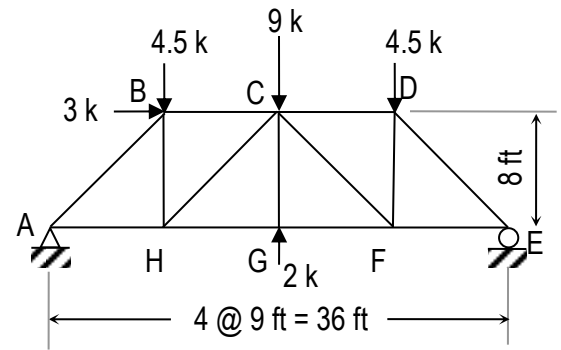

Figure 2a

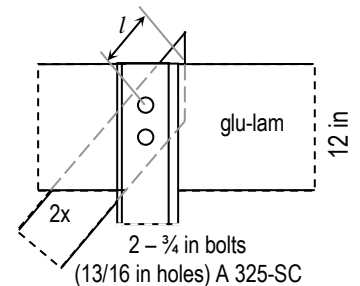

Figure 2b (side)

FIND:

- The member forces in BC and HC using the method of sections.
- The moment of inertia about the  $x$  axis for the steel web members by completing the chart of Table 2 when  $\hat{y} = 1.102''$  from the top of the section.
- The maximum factored compressive load capacity for the vertical steel web members when  $r_x = 0.93 \text{ in.}$  and  $r_y = 1.78 \text{ in.}$
- If the top glu-lam chord from C to D is adequate with a member force of 9.75 kips in compression and a maximum unbraced length of 9 ft. laterally. The ends are pinned in the plane of the truss.
- The size of the weld required when the factored shear per unit length is 4.6 k/in.
- The minimum length,  $l$ , in the 2x from the center of the bolt holes to the vertically cut end of the member as shown in Figure 2b when the maximum shear force transmitted by the bolts is 2500 lb.
- The maximum (factored) shear in the bolts of the connection shown considering the vertical member only.
- The *design capacity* of the bolted connection shown with respect to bearing in the steel **and** the top chord.
- The *design capacity* of the bolted connection shown with respect to tension for the steel member when the shear lag factor,  $U = 0.8$ .

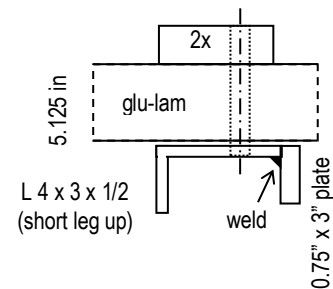

Figure 2c (top)

Table 2

	A (in <sup>2</sup> )	I <sub>x</sub> (in <sup>4</sup> )	d <sub>y</sub> (in)	Ad <sub>y</sub> <sup>2</sup> (in <sup>3</sup> )
angle	3.25			
plate	2.25			

**Disclaimer: Answers have NOT been painstakingly researched.**

i) BC = 11.25 k (C)	j)	k) 100.6 k
l)	m) 1/4 in.	n) 4.39 in.
o) 18.98 k	p) 5.8 k (78.3 k)	q) 176.2 k (178.2 k)

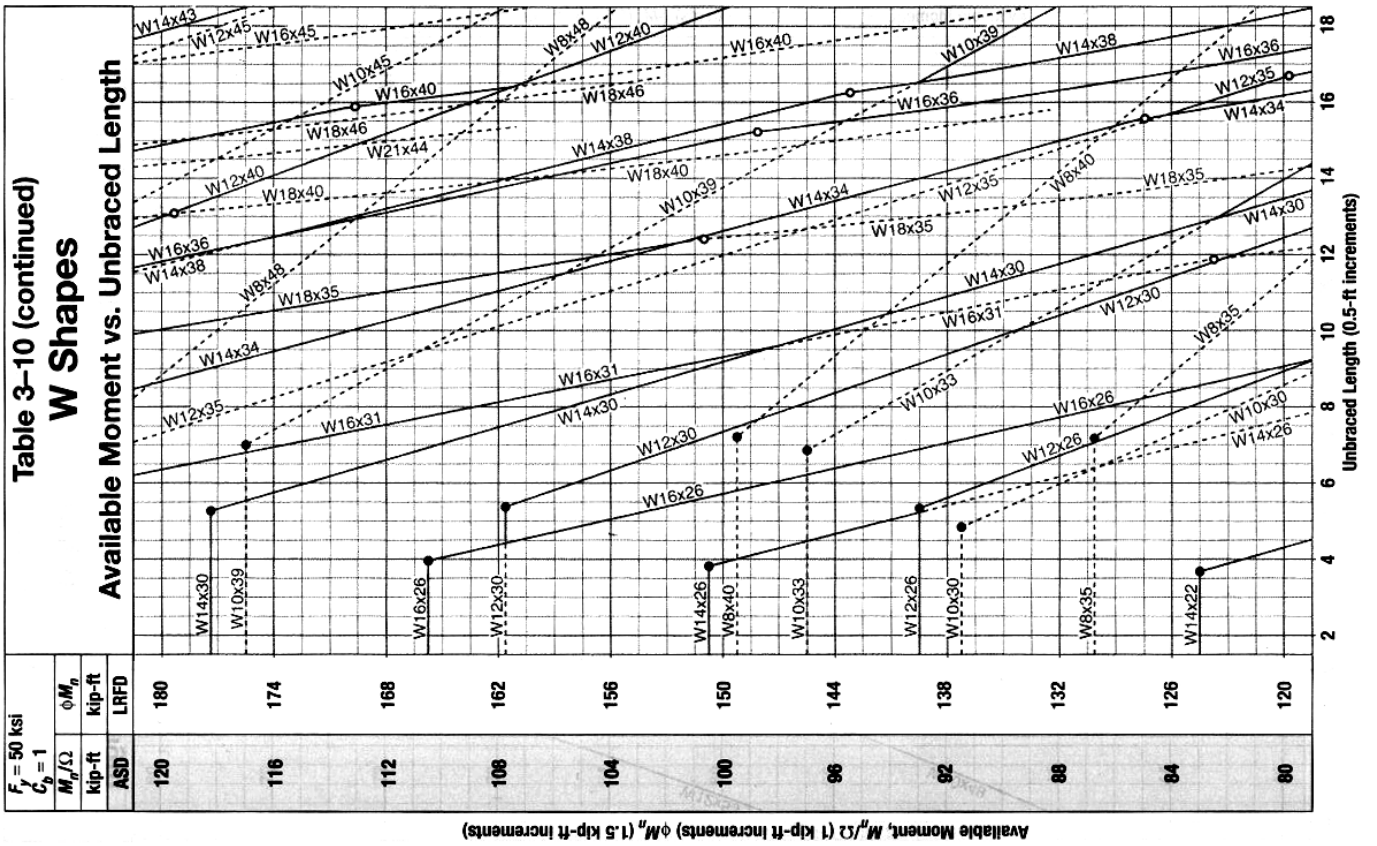
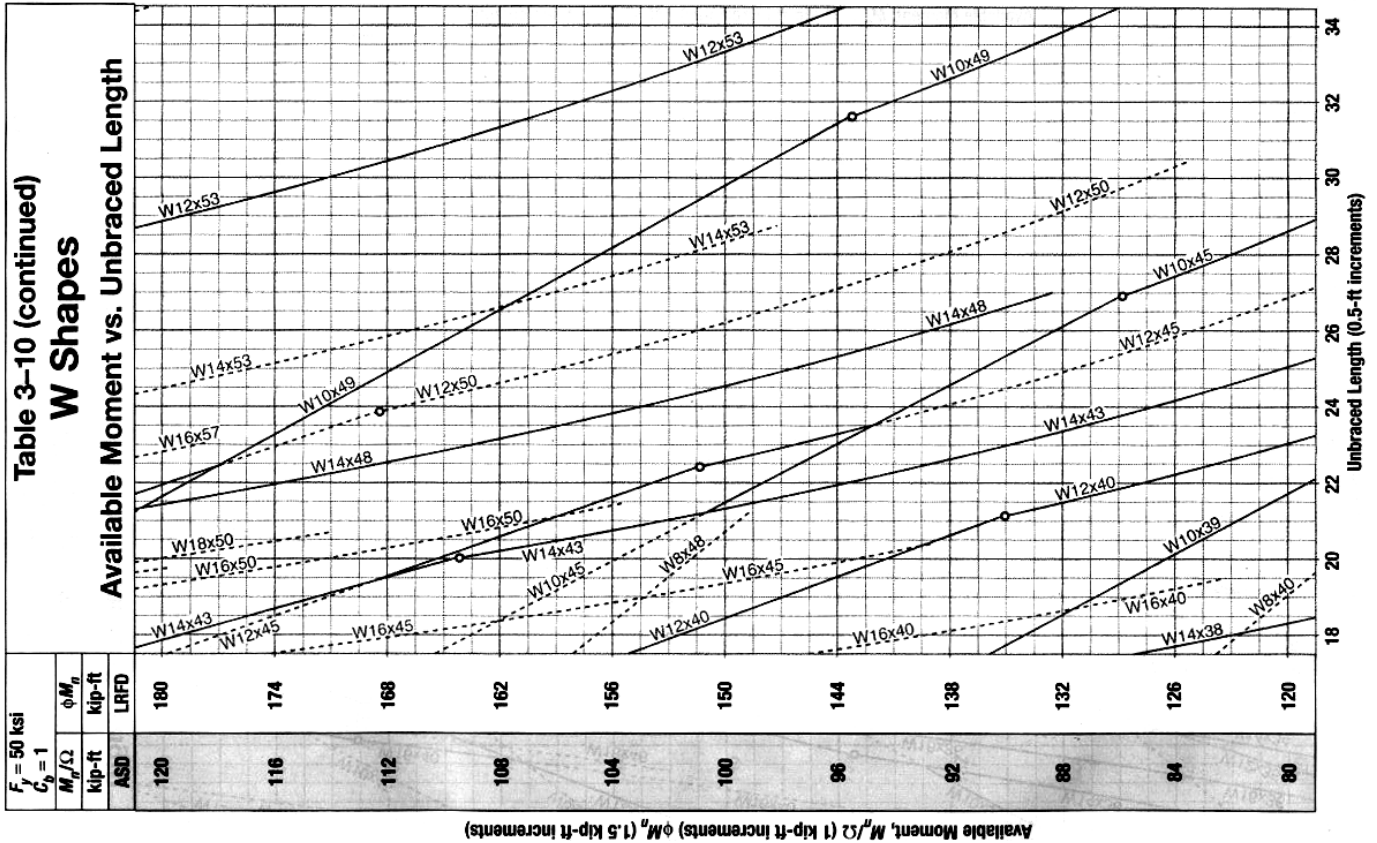

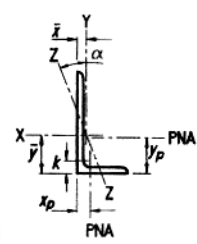

**Table 1-7  
Angles  
Properties**

(Values with respect to orientation with longer leg vertical)

**Table 1-7 (continuation)  
Angles  
Properties**

Shape	k	Wt.	Area, A	Axis X-X						Flexural-Torsional Properties			Axis Y-Y					
				I	S	r	$\bar{y}$	Z	$y_p$	J	$C_w$	$\bar{r}_o$	I	S	r	$\bar{x}$	Z	$x_p$
				in. <sup>4</sup>	in. <sup>3</sup>	in.	in.	in. <sup>3</sup>	in.	in. <sup>4</sup>	in. <sup>6</sup>	in.	in. <sup>4</sup>	in. <sup>3</sup>	in.	in.	in. <sup>3</sup>	in.
L4x4x3/4	1 1/8	18.5	5.44	7.62	2.79	1.18	1.27	5.02	0.679	1.02	1.12	2.10	7.62	2.79	1.18	1.27	5.01	0.679
x5/8	1	15.7	4.61	6.62	2.38	1.20	1.22	4.28	0.576	0.610	0.680	2.13	6.62	2.38	1.20	1.22	4.28	0.576
x1/2	7/8	12.8	3.75	5.52	1.96	1.21	1.18	3.50	0.468	0.322	0.366	2.16	5.52	1.96	1.21	1.18	3.50	0.468
x7/16	13/16	11.3	3.31	4.93	1.73	1.22	1.15	3.10	0.413	0.220	0.252	2.18	4.93	1.73	1.22	1.15	3.10	0.413
x3/8	3/4	9.80	2.86	4.32	1.50	1.23	1.13	2.69	0.357	0.141	0.162	2.19	4.32	1.50	1.23	1.13	2.68	0.357
x5/16	11/16	8.20	2.40	3.67	1.27	1.24	1.11	2.26	0.300	0.0832	0.0963	2.21	3.67	1.27	1.24	1.11	2.26	0.300
x1/4	5/8	6.60	1.94	3.00	1.03	1.25	1.08	1.82	0.242	0.0438	0.0505	2.22	3.00	1.03	1.25	1.08	1.82	0.242
L4x3 1/2x1/2	7/8	11.9	3.50	5.30	1.92	1.23	1.24	3.46	0.497	0.301	0.302	2.03	3.76	1.50	1.04	0.994	2.69	0.438
x3/8	3/4	9.10	2.67	4.15	1.48	1.25	1.20	2.66	0.433	0.132	0.134	2.06	2.96	1.16	1.05	0.947	2.06	0.334
x5/16	11/16	7.70	2.25	3.53	1.25	1.25	1.17	2.24	0.401	0.0782	0.0798	2.08	2.52	0.980	1.06	0.923	1.74	0.281
x1/4	5/8	6.20	1.81	2.89	1.01	1.26	1.14	1.81	0.368	0.0412	0.0419	2.09	2.07	0.794	1.07	0.897	1.40	0.227
L4x3x5/8	1	13.6	3.89	6.01	2.28	1.23	1.37	4.08	0.810	0.529	0.472	1.91	2.85	1.34	0.845	0.867	2.45	0.498
x1/2	7/8	11.1	3.25	5.02	1.87	1.24	1.32	3.36	0.747	0.281	0.255	1.94	2.40	1.10	0.858	0.822	1.99	0.407
x3/8	3/4	8.50	2.48	3.94	1.44	1.26	1.27	2.60	0.683	0.123	0.114	1.97	1.89	0.851	0.873	0.775	1.52	0.311

Available Critical Stress,  $\phi_c F_{cr}$ , for Compression Members, ksi ( $F_y = 36$  ksi and  $\phi_c = 0.90$ )

KL/r	$\phi_c F_{cr}$	KL/r	$\phi_c F_{cr}$	KL/r	$\phi_c F_{cr}$	KL/r	$\phi_c F_{cr}$	KL/r	$\phi_c F_{cr}$
1	32.4	41	29.7	81	22.9	121	15.0	161	8.72
2	32.4	42	29.5	82	22.7	122	14.8	162	8.61
3	32.4	43	29.4	83	22.5	123	14.6	163	8.50
4	32.4	44	29.3	84	22.3	124	14.4	164	8.40
5	32.4	45	29.1	85	22.1	125	14.2	165	8.30
6	32.3	46	29.0	86	22.0	126	14.0	166	8.20
7	32.3	47	28.8	87	21.8	127	13.9	167	8.10
8	32.3	48	28.7	88	21.6	128	13.7	168	8.00
9	32.3	49	28.6	89	21.4	129	13.5	169	7.91
10	32.2	50	28.4	90	21.2	130	13.3	170	7.82
11	32.2	51	28.3	91	21.0	131	13.1	171	7.73
12	32.2	52	28.1	92	20.8	132	12.9	172	7.64
13	32.1	53	27.9	93	20.5	133	12.8	173	7.55
14	32.1	54	27.8	94	20.3	134	12.6	174	7.46
15	32.0	55	27.6	95	20.1	135	12.4	175	7.38
16	32.0	56	27.5	96	19.9	136	12.2	176	7.29
17	31.9	57	27.3	97	19.7	137	12.0	177	7.21
18	31.9	58	27.1	98	19.5	138	11.9	178	7.13
19	31.8	59	27.0	99	19.3	139	11.7	179	7.05
20	31.7	60	26.8	100	19.1	140	11.5	180	6.97
21	31.7	61	26.6	101	18.9	141	11.4	181	6.90
22	31.6	62	26.5	102	18.7	142	11.2	182	6.82
23	31.5	63	26.3	103	18.5	143	11.0	183	6.75
24	31.4	64	26.1	104	18.3	144	10.9	184	6.67
25	31.4	65	25.9	105	18.1	145	10.7	185	6.60
26	31.3	66	25.8	106	17.9	146	10.6	186	6.53
27	31.2	67	25.6	107	17.7	147	10.5	187	6.46
28	31.1	68	25.4	108	17.5	148	10.3	188	6.39
29	31.0	69	25.2	109	17.3	149	10.2	189	6.32
30	30.9	70	25.0	110	17.1	150	10.0	190	6.26
31	30.8	71	24.8	111	16.9	151	9.91	191	6.19
32	30.7	72	24.7	112	16.7	152	9.78	192	6.13
33	30.6	73	24.5	113	16.5	153	9.65	193	6.06
34	30.5	74	24.3	114	16.3	154	9.53	194	6.00
35	30.4	75	24.1	115	16.2	155	9.40	195	5.94
36	30.3	76	23.9	116	16.0	156	9.28	196	5.88
37	30.1	77	23.7	117	15.8	157	9.17	197	5.82
38	30.0	78	23.5	118	15.6	158	9.05	198	5.76
39	29.9	79	23.3	119	15.4	159	8.94	199	5.70
40	29.8	80	23.1	120	15.2	160	8.82	200	5.65