

## Method of Sections for Truss Analysis

Joint Configurations (special cases to recognize for faster solutions)

Case 1) Two Bodies Connected

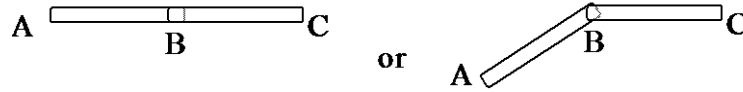

$F_{AB}$  has to be equal and opposite to  $F_{BC}$

Case 2) Three Bodies Connected with Two Bodies in Line

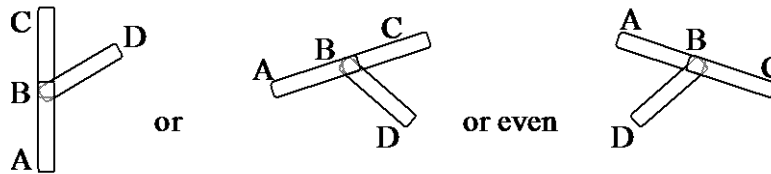

$F_{AB}$  and  $F_{BC}$  have to be equal, and  $F_{BD}$  has to have zero force.

Case 3) Three Bodies Connected and a Force – 2 Bodies aligned & 1 Body and a Force are Aligned  
 Four Bodies Connected - 2 Bodies Aligned and the Other 2 Bodies Aligned

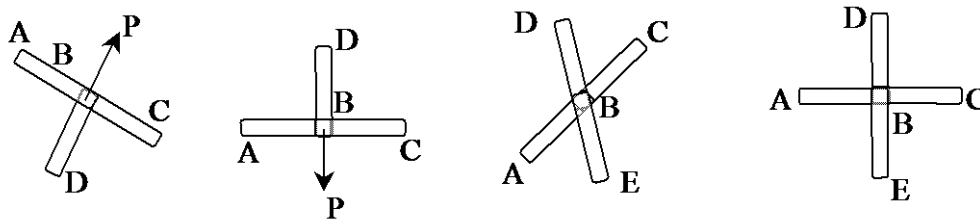

$F_{AB}$  has to equal  $F_{BC}$ , and [ $F_{BD}$  has to equal P] or [ $F_{BD}$  has to equal  $F_{BE}$ ]

Method of Sections (relies on internal forces being in equilibrium with external forces on a section)

1. Determine support reaction forces.
2. Cut a section in such a way that force action lines intersect.
3. Solve for equilibrium. Sum moments about an intersection of force lines of action

Advantages: Quick when you only need one or two forces (only 3 equations needed)

Disadvantages: Not always easy to find a place to cut a section or see where force lines intersect

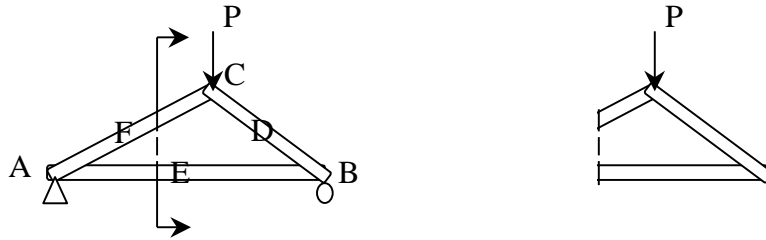

- Compound Truss: A truss assembled of simple trusses and additional links. It has  $b=2n-3$ , is statically determinate, rigid and completely constrained with a pin and roller. It can be identified by triangles with pins in the middle of some sides.
- Statically Indeterminate Trusses:
  - Occur if there are more members than equations for all the joints
  - OR if there are more reaction supports unknowns than 3
- Diagonal Tension Counters: Crossed bracing of cables or slender members is commonly used in bridge trusses, buildings and towers. These trusses look indeterminate, but can be solved statically because the bracing cannot hold a compressive force. The members are excluded in the analysis.

Method:

1. Determine support reaction forces.
2. Cut a section in such a way that the tension counters are exposed.
3. Solve for force equilibrium in  $y$  with one counter. If the value is positive (in tension), this is the solution.
4. Solve for force equilibrium in  $y$  with the other counter.

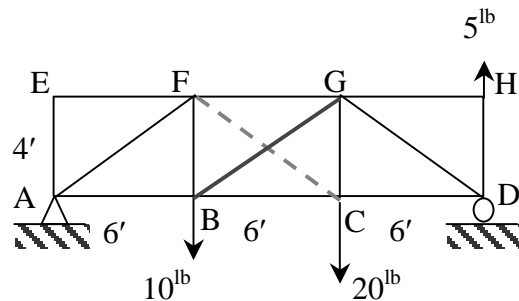

Example 1 (pg 26 & 33)

Using the method of sections, determine member forces in JH and EN.

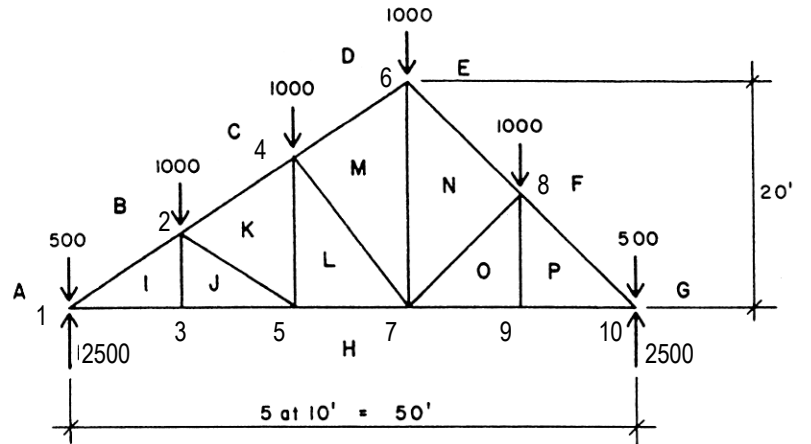
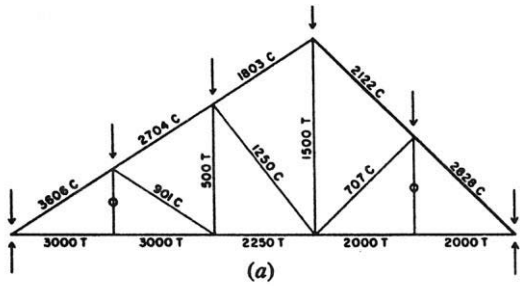

Space diagram

**Example 2**

Using the method of sections, determine member forces in BC, CD and BD.

SOLUTION:

Find the support reactions from rigid body equilibrium, or in this case, from load tracing with symmetrical loads.

Draw a section line through the members of interest, *cutting through no more than 3 members* to separate the truss into two pieces. In this case, BC and CD can be cut through, while BD will need another section.

Draw one of the sections, exposing the member forces. Drawing them “out” or “away” from the cut assumes tension. BC is drawn in compression. So is DC, but because it has a 45 degree angle, the components will have the same magnitude.

Find a point to sum moments where two unknown forces intersect. This may be on a point of the section or *off* the section. X is such a location where the line of action of BC intersects that of DE. For every 15 ft to the left, the line slopes down 5 ft, so X is located  $(10\text{ ft} / 5\text{ ft})15\text{ ft} = 30\text{ ft}$  to the left of B.

$$\Sigma M_X = -450\text{ lb}(15\text{ ft}) + 300\text{ lb}(30\text{ ft}) + DC_y(30\text{ ft}) = 0$$

$$DC_y = -75\text{ lb}, \text{ so } DC = DC_y/\sin 45 = 106\text{ lb tension}$$

(compression was assumed, but the answer was negative indicating our assumption wasn't verified).

(Notice that  $DC_x$  and  $DC_y$  “slid” down to D and then the lever arm for  $DC_x$  was 0. The components can also slide to the other end point of the member to locate the lever arms)

Summing at D where DC and DE intersect means there will be no lever arms. Sliding the components of BC to B means there will be no lever arm for  $BC_y$ :

$$\Sigma M_D = 450\text{ lb}(15\text{ ft}) - BC_x(10\text{ ft}) = 0 \quad BC_x = 675\text{ lb}, \text{ so } BC = BC_x \sqrt{10}/3 = 711.5\text{ lb compression}$$

Draw a section line that passes through BD and cuts through no more than three members.

If we hadn't already found BC, we could sum moments at point X again to eliminate BC and AD from our equation, leaving BD.

But it is obvious that we have only one unknown y force, which is BD:

$$\Sigma F_y = 450\text{ lb} - BD - 711.5\text{ lb} \left( \frac{1}{\sqrt{10}} \right) = 0 \quad BD = 225\text{ lb tension}$$

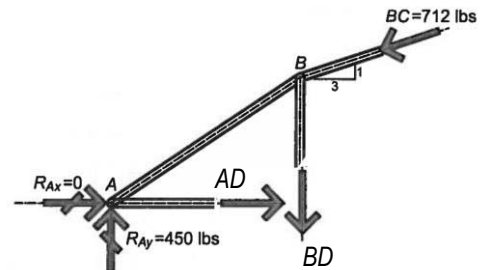
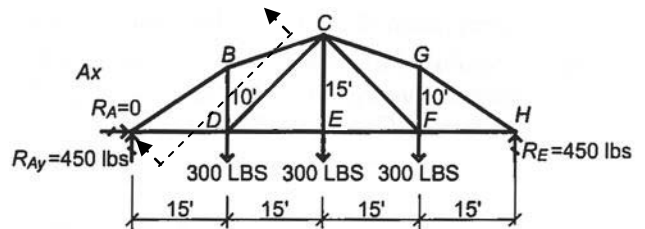
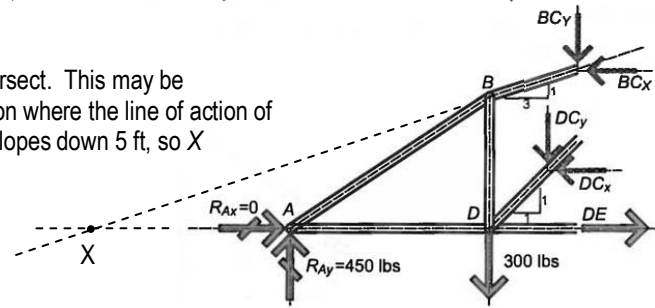
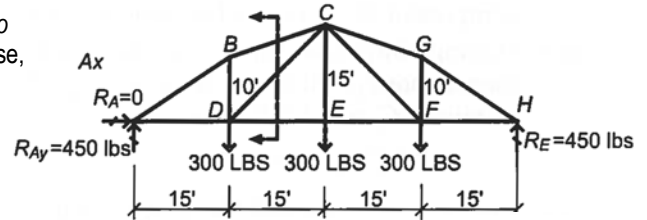
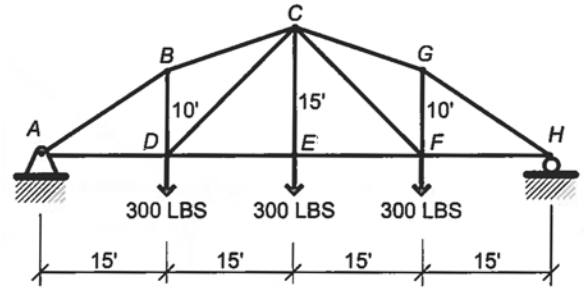

Example 3

A 64-foot parallel chord truss (Figure ) supports horizontal and vertical loads as shown. Using the method of sections, determine the member forces  $BC$ ,  $HG$ , and  $GD$ .

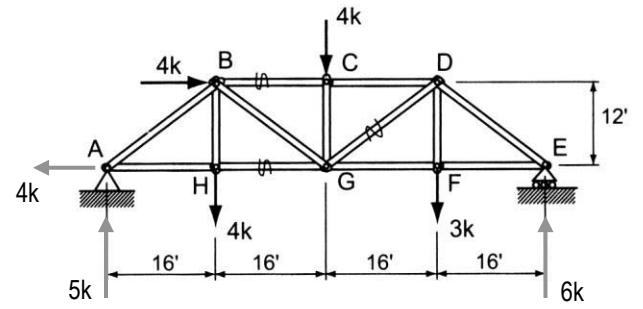

**Example 4**

Using the method of sections, determine member forces in FE, EB, BC, AB and FB.

SOLUTION:

A section can't pass through 5 members, so there will have to be two sections. The first passes through FE, EB and BC.

FE is shown assumed to be in compression, while the other forces are drawn assumed to be in tension.

There can be only two intersections when two of the three forces are parallel – at E and B:

$$\sum M_E = -100^{lb}(6\text{ft}) + BC(8\text{ft}) = 0$$

$$BC = 75^{lb} \text{ (T)}$$

$$\sum M_B = -100^{lb}(12\text{ft}) + FE(8\text{ft}) = 0$$

$$FE = 150^{lb} \text{ (C)}$$

Because EB is the only unknown force with a y component, it is useful to sum forces in the y direction (although it also has the only remaining unknown x component):

$$\sum F_y = 100^{lb} - EB\left(\frac{8\text{ft}}{\sqrt{100\text{ft}}}\right) = 0$$

$$\text{(or } \sum F_x = 150^{lb} - 75^{lb} - EB\left(\frac{6\text{ft}}{\sqrt{100\text{ft}}}\right) = 0)$$

$$EB = 125^{lb} \text{ (T)}$$

A second section can be drawn through AB, FB and FE.

There are three points of intersection of the unknown forces - at A, F and B. B is not on the section, but we know where it is.

$$\sum M_A = 200^{lb}(6\text{ft}) - FB(6\text{ft}) = 0 \quad FB = 200^{lb} \text{ (C)}$$

$$\sum M_F = 200^{lb}(6\text{ft}) - AB_y(6\text{ft}) = 0 \text{ (sliding AB components to A)}$$

$$AB = AB_y\left(\frac{\sqrt{100}}{8}\right) = 250^{lb} \text{ (T)}$$

$$\text{or } \sum M_F = 200^{lb}(6\text{ft}) - AB_x(8\text{ft}) = 0 \text{ (sliding AB components to B)}$$

$$AB = AB_x\left(\frac{\sqrt{100}}{6}\right) = 250^{lb} \text{ (T)}$$

$$\sum M_B = 200^{lb}(6\text{ft}) - FE(8\text{ft}) = 0$$

$$FE = 150^{lb} \text{ (C)}$$

