

**ARCHITECTURAL STRUCTURES:
FORM, BEHAVIOR, AND DESIGN**

ARCH 331

DR. ANNE NICHOLS

SUMMER 2014

**lecture
two**

**forces and
moments**

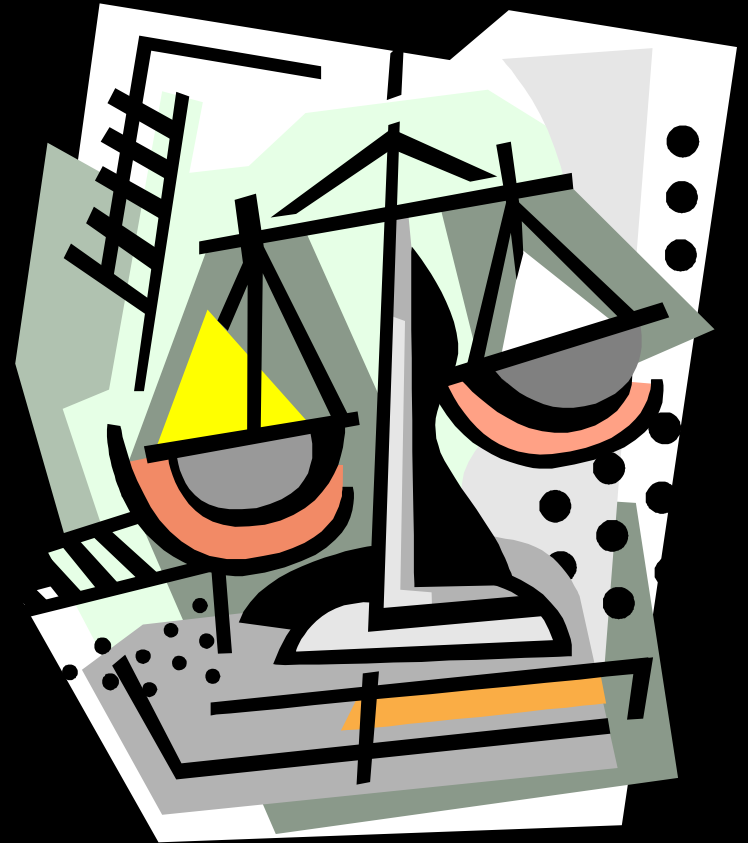

Structural Math

- *quantify environmental loads*
 - *how big is it?*
- *evaluate geometry and angles*
 - *where is it?*
 - *what is the scale?*
 - *what is the size in a particular direction?*
- *quantify what happens in the structure*
 - *how big are the internal forces?*
 - *how big should the beam be?*

Structural Math

- *physics takes observable phenomena and relates the measurement with rules: mathematical relationships*
- *need*
 - *reference frame*
 - *measure of length, mass, time, direction, velocity, acceleration, work, heat, electricity, light*
 - *calculations & geometry*

Physics for Structures

- *measures*
 - *US customary & SI*

<i>Units</i>	<i>US</i>	<i>SI</i>
<i>Length</i>	<i>in, ft, mi</i>	<i>mm, cm, m</i>
<i>Volume</i>	<i>gallon</i>	<i>liter</i>
<i>Mass</i>	<i>lb mass</i>	<i>g, kg</i>
<i>Force</i>	<i>lb force</i>	<i>N, kN</i>
<i>Temperature</i>	<i>F</i>	<i>C</i>

Physics for Structures

- *scalars – any quantity*
- *vectors - quantities with direction*
 - *like displacements*
 - *summation results in the “straight line path” from start to end*
 - *normal vector is perpendicular to something*

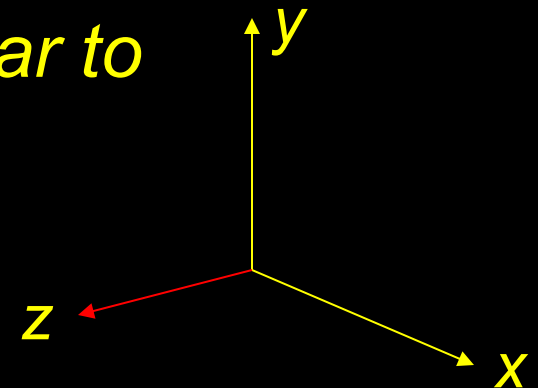
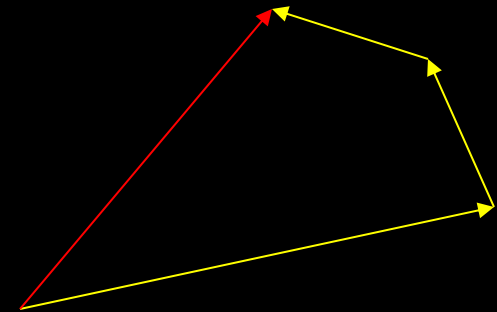

Language

- *symbols for operations: +, -, /, x*
- *symbols for relationships: (), =, <, >*
- *algorithms*

- *cancellation*

$$\frac{2}{5} \times \frac{5}{6} = \frac{2}{6} = \frac{2}{2 \times 3} = \frac{1}{3}$$

- *factors*

- *signs*

$$\frac{x}{6} = \frac{1}{3}$$

- *ratios and proportions*

- *power of a number*

$$10^3 = 1000$$

- *conversions, ex. 1X = 10 Y*

- *operations on both sides of equality*

$$\frac{10Y}{1X} \text{ or } \frac{1X}{10Y} = 1$$

On-line Practice

- *eCampus / Study Aids*

Take Test: Math Practice

Description	Math practice for structures (for self-grading).
Instructions	Calculated the required quantities, being careful to use an appropriate number of significant digits.
Multiple Attempts	This Test allows multiple attempts.
Force Completion	This Test can be saved and resumed later.

∨ Question Completion Status:

Save All Answers Save and Submit

Question 1 1 points Save Answer

Convert the force 6.85 kN to pounds , and kips .

Geometry

- *angles*

- *right* = 90°

- *acute* $< 90^\circ$

- *obtuse* $> 90^\circ$

- π = 180°

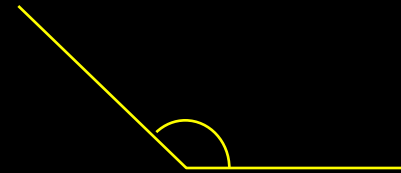
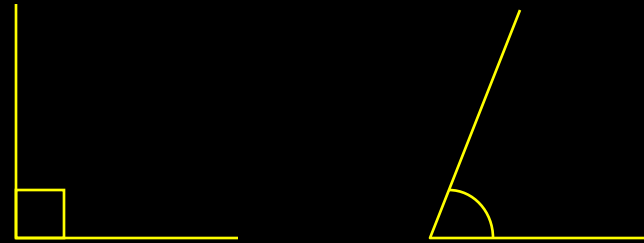

- *triangles*

- *area* = $\frac{b \times h}{2}$

- *hypotenuse*

- *total of angles* = 180°

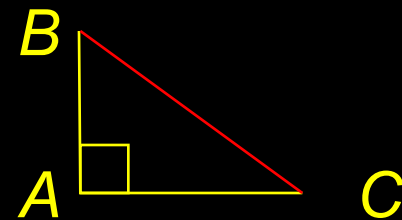

$$AB^2 + AC^2 = BC^2$$

Geometry

- *lines and relation to angles*
 - *parallel lines can't intersect*
 - *perpendicular lines cross at 90°*
 - *intersection of two lines is a point*
 - *opposite angles are equal when two lines cross*

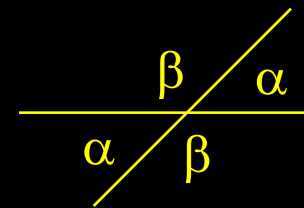
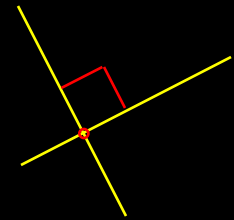
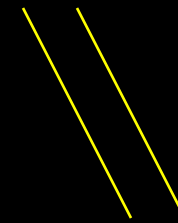

Geometry

– *intersection of a line with parallel lines results in identical angles*

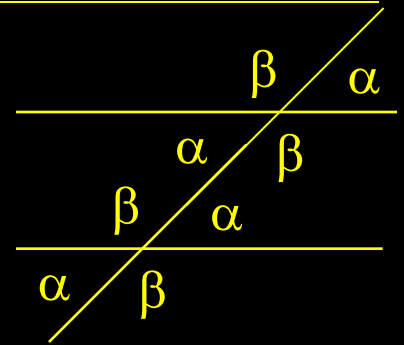

– *two lines intersect in the same way, the angles are identical*

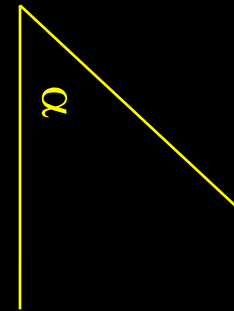
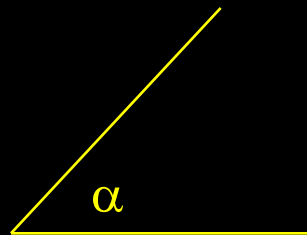
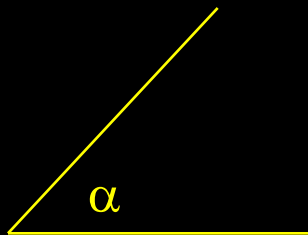

Geometry

- sides of two angles are parallel and intersect opposite way, the angles are supplementary - the sum is 180°

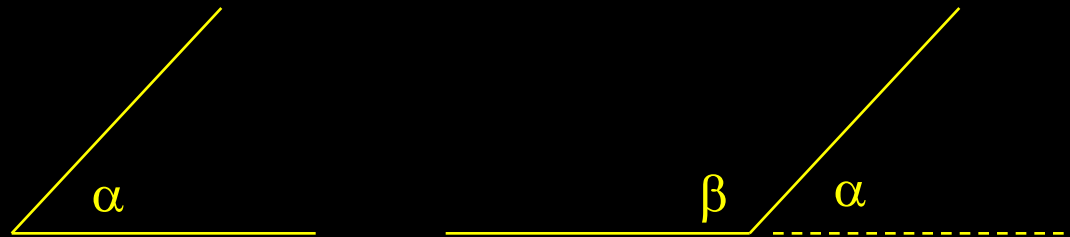

- two angles that sum to 90° are said to be complimentary

$$\beta + \gamma = 90^\circ$$

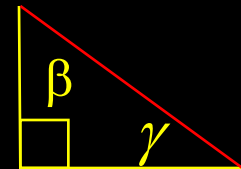

Geometry

- sides of two angles bisect a right angle (90°), the angles are complimentary

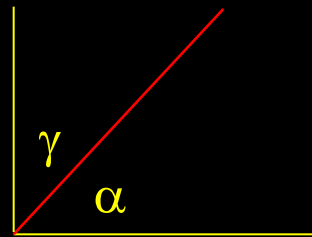

$$\alpha + \gamma = 90^\circ$$

- right angle bisects a straight line, remaining angles are complimentary

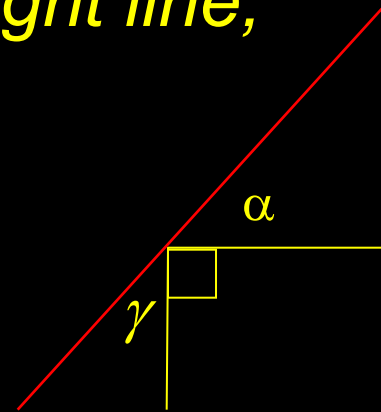

Geometry

– similar triangles have proportional sides

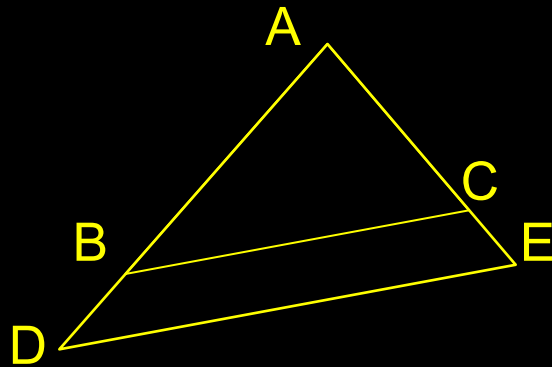

$$\frac{AB}{AD} = \frac{AC}{AE} = \frac{BC}{DE}$$

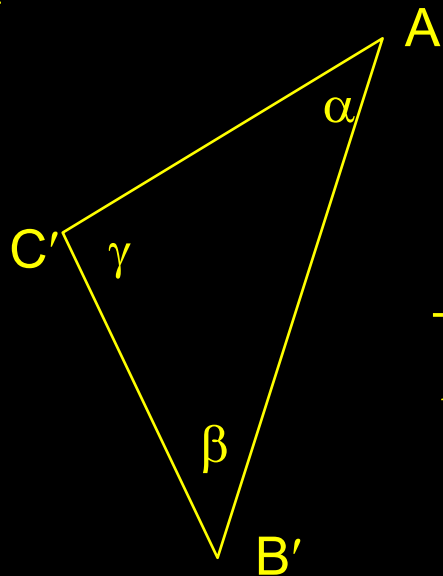
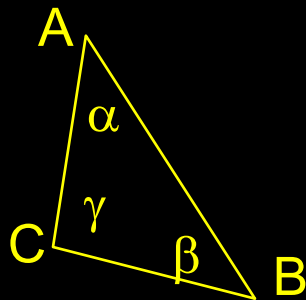

$$\frac{AB}{A'B'} = \frac{AC}{A'C'} = \frac{BC}{B'C'}$$

Trigonometry

- for right triangles

$$\sin = \frac{\textit{opposite side}}{\textit{hypotenuse}} = \sin \alpha = \frac{AB}{CB}$$

$$\cos = \frac{\textit{adjacent side}}{\textit{hypotenuse}} = \cos \alpha = \frac{AC}{CB}$$

$$\tan = \frac{\textit{opposite side}}{\textit{adjacent side}} = \tan \alpha = \frac{AB}{AC}$$

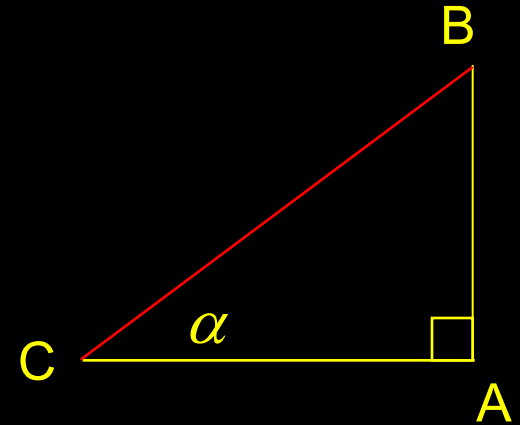

SOHCAHTOA

Trigonometry

- *cartesian coordinate system*
 - origin at $0,0$
 - coordinates in (x,y) pairs
 - x & y have signs

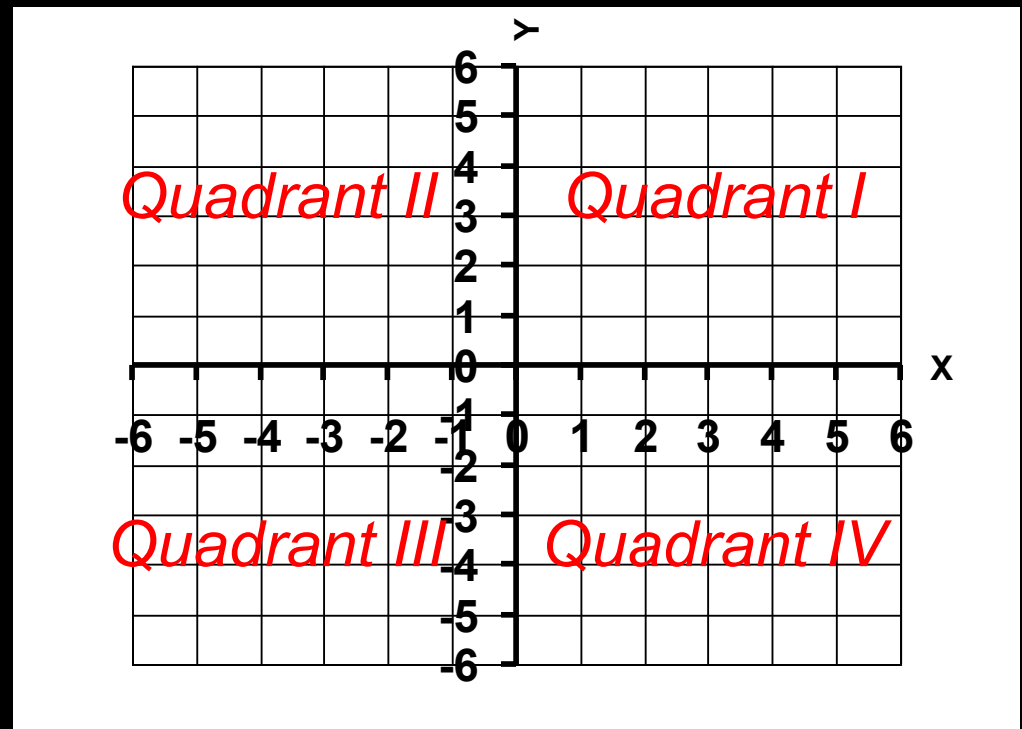

Trigonometry

- for angles starting at positive x
 - sin is y side
 - cos is x side

$\sin < 0$ for $180-360^\circ$
 $\cos < 0$ for $90-270^\circ$
 $\tan < 0$ for $90-180^\circ$
 $\tan < 0$ for $270-360^\circ$

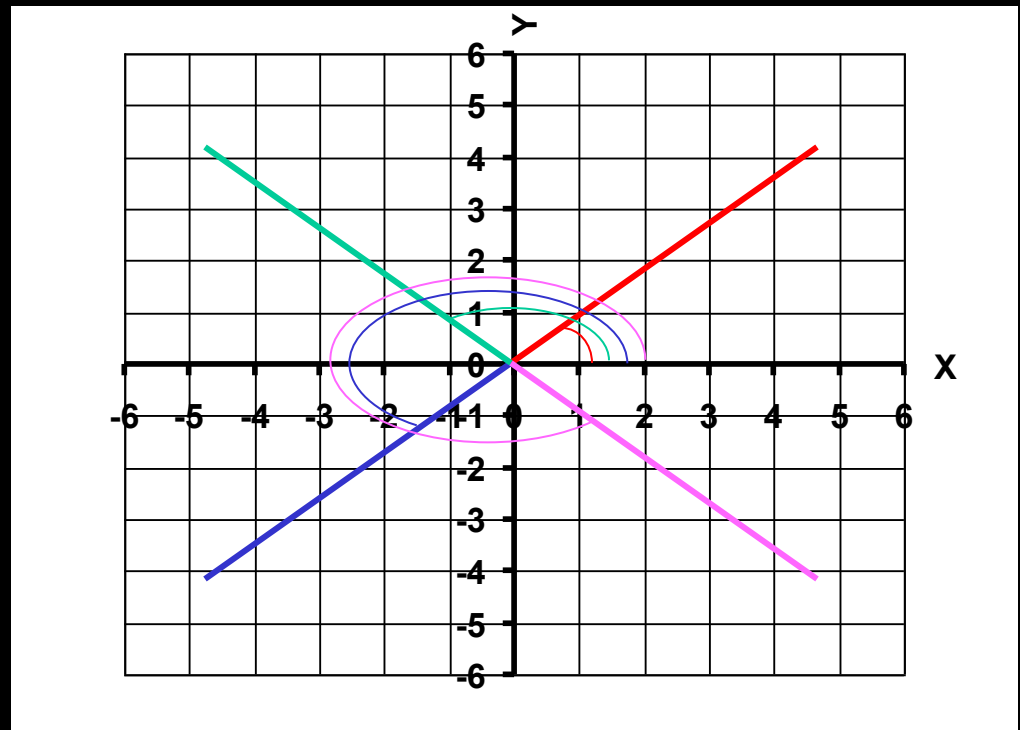

Trigonometry

- for all triangles
 - sides A , B & C are opposite angles α , β & γ

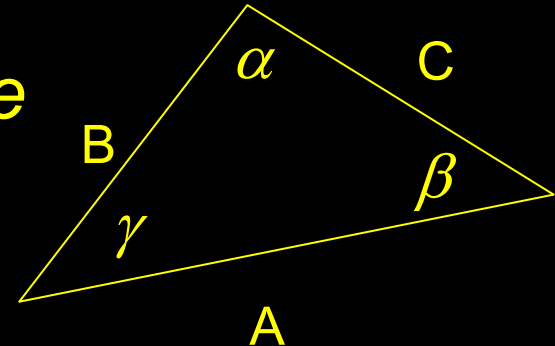

- LAW of SINES

$$\frac{\sin \alpha}{A} = \frac{\sin \beta}{B} = \frac{\sin \gamma}{C}$$

- LAW of COSINES

$$A^2 = B^2 + C^2 - 2BC \cos \alpha$$

Algebra

- *equations (something = something)*
- *constants*
 - *real numbers or shown with a, b, c...*
- *unknown terms, variables*
 - *names like R, F, x, y*
- *linear equations*
 - *unknown terms have no exponents*
- *simultaneous equations*
 - *variable set satisfies all equations*

Algebra

- *solving one equation*

- *only works with one variable*

- *ex:*

- *add to both sides*

$$2x - 1 = 0$$

$$2x - 1 + 1 = 0 + 1$$

$$2x = 1$$

- *divide both sides*

$$\frac{2x}{2} = \frac{1}{2}$$

- *get x by itself on a side*

$$x = \frac{1}{2}$$

Algebra

- *solving one equations*

- *only works with one variable*

- *ex:* $2x - 1 = 4x + 5$

- *subtract from both sides*

$$2x - 1 - 2x = 4x + 5 - 2x$$

- *subtract from both sides*

$$-1 - 5 = 2x + 5 - 5$$

- *divide both sides*

$$\frac{-6}{2} = \frac{-3 \cdot 2}{2} = \frac{2x}{2}$$

- *get x by itself on a side*

$$x = -3$$

Algebra

- *solving two equation*

- *only works with two variables*

- *ex:* $2x + 3y = 8$

- *look for term similarity*

$$12x - 3y = 6$$

- *can we add or subtract to eliminate one term?*

- *add*

$$2x + 3y + 12x - 3y = 8 + 6$$

$$14x = 14$$

- *get x by itself on a side*

$$\frac{14x}{14} = \frac{14}{14} = x = 1$$

Forces

- *statics*
 - *physics of forces and reactions on bodies and systems*
 - *equilibrium (bodies at rest)*
- *forces*
 - *something that exerts on an object:*
 - *motion*
 - *tension*
 - *compression*

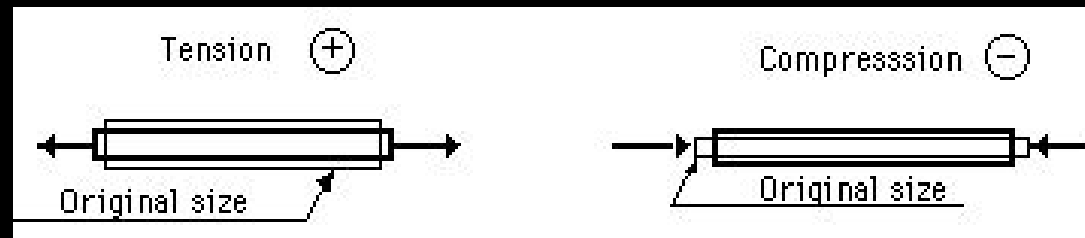

Force

- “*action of one body on another that affects the state of motion or rest of the body*”
- *Newton’s 3rd law:*
 - *for every force of action there is an equal and opposite reaction along the same line*

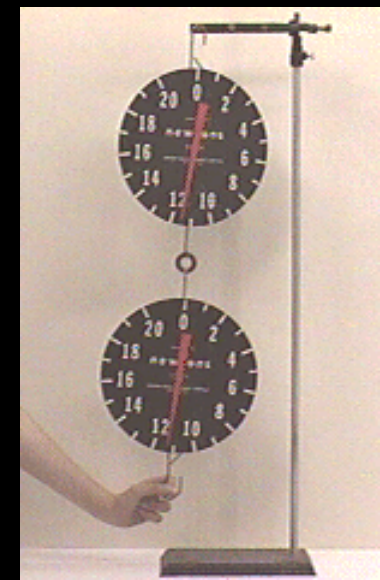
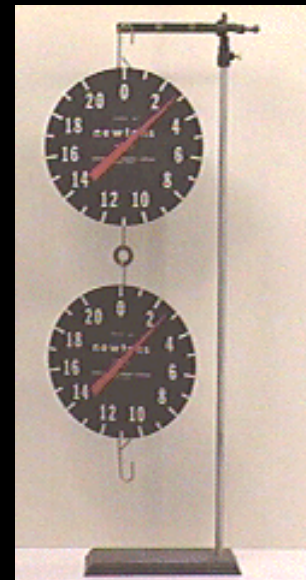

<http://www.physics.umd.edu>

Force Characteristics

- *applied at a point*
- *magnitude*
 - *Imperial units: lb, k (kips)*
 - *SI units: N (newtons), kN*
- *direction*

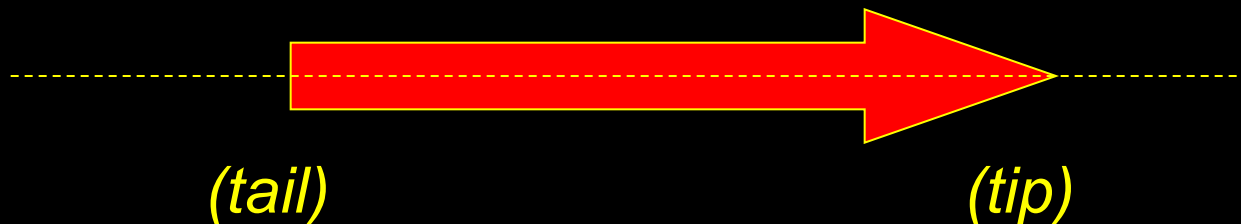

Forces on Rigid Bodies

- *for statics, the bodies are ideally rigid*
- *can translate and rotate*
- *internal forces are*
 - *in bodies*
 - *between bodies (connections)*
- *external forces act on bodies*

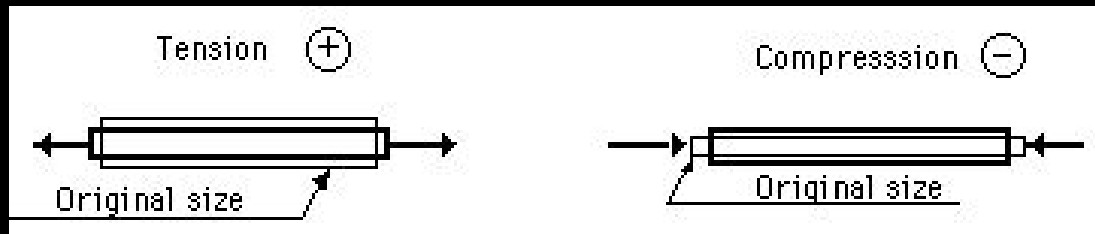
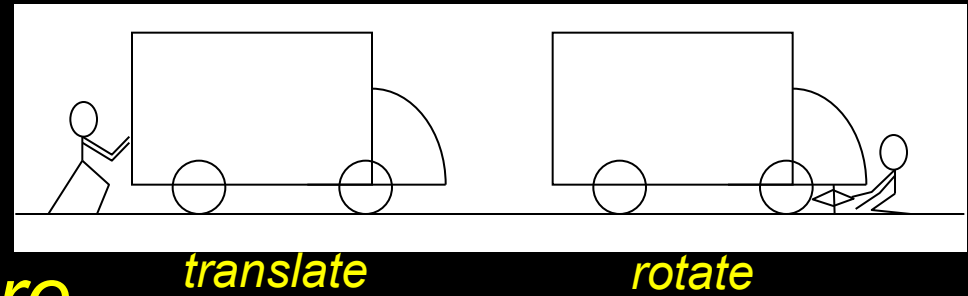

Transmissibility

- *the force stays on the same line of action*
- *truck can't tell the difference*

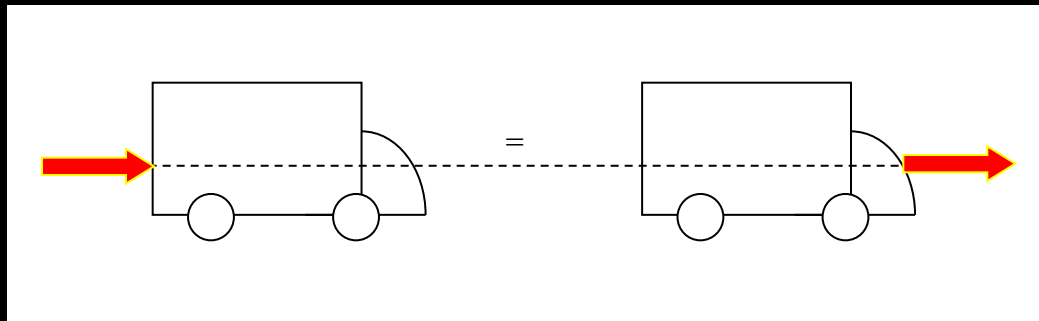

- *only valid for EXTERNAL forces*

Force System Types

- *collinear*

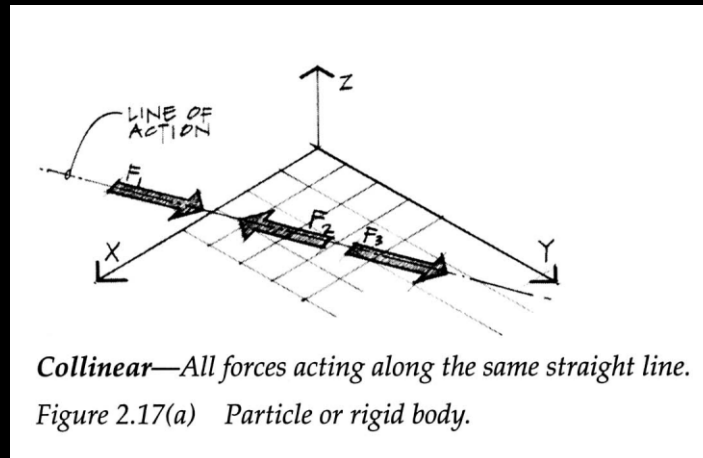

Force System Types

- *coplanar*

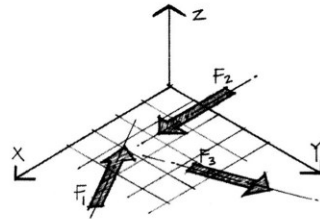

Coplanar—All forces acting in the same plane.

Figure 2.17(b) Rigid bodies.

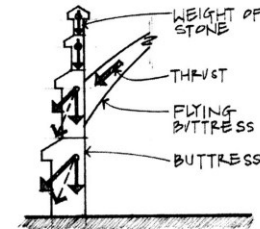

Forces in a buttress system.

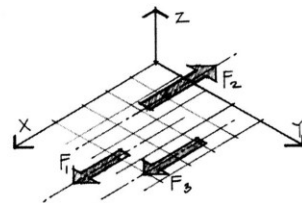

Coplanar, parallel—All forces are parallel and act in the same plane.

Figure 2.17(c) Rigid bodies.

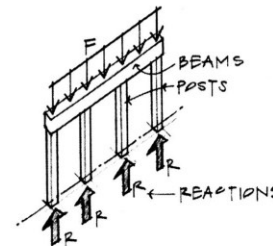

A beam supported by a series of columns.

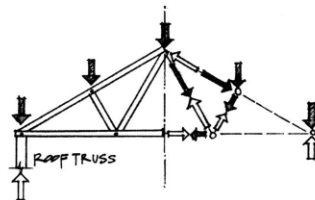

Loads applied to a roof truss.

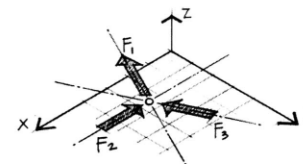

Coplanar, concurrent—All forces intersect at a common point and lie in the same plane.

Figure 2.17(d) Particle or rigid body.

Force System Types

- *space*

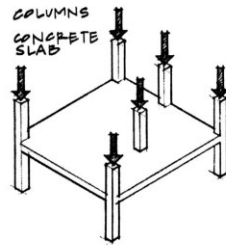

Column loads in a concrete building.

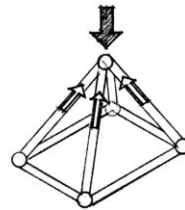

One component of a three-dimensional space frame.

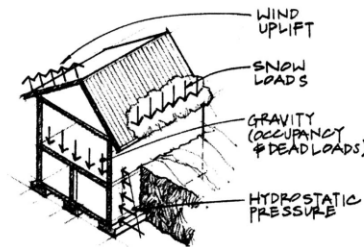

Array of forces acting simultaneously on a house.

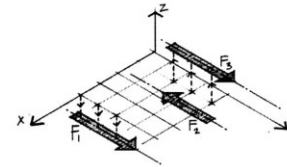

Noncoplanar, parallel—All forces are parallel to each other, but not all lie in the same plane.

Figure 2.17(e) Rigid bodies.

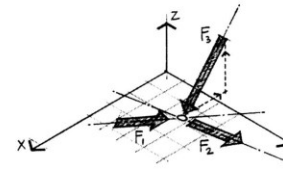

Noncoplanar, concurrent—All forces intersect at a common point but do not all lie in the same plane.

Figure 2.17(f) Particle or rigid bodies.

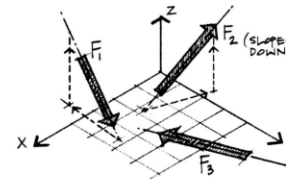

Noncoplanar, nonconcurrent—All forces are skewed.

Figure 2.17(g) Rigid bodies.

Adding Vectors

- *graphically*
 - *parallelogram law*
 - *diagonal*
 - *long for 3 or more vectors*
 - *tip-to-tail*
 - *more convenient with lots of vectors*

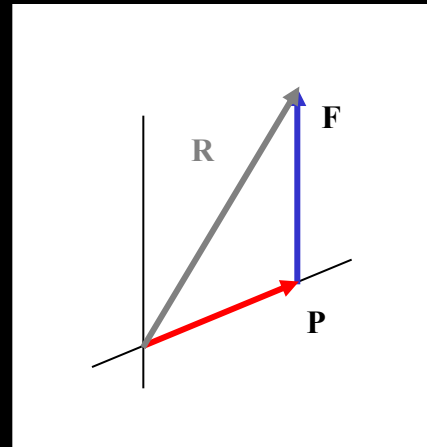
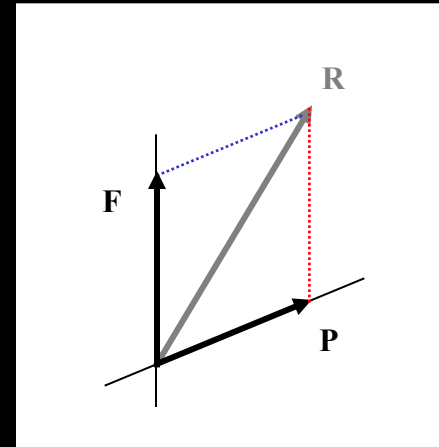

Force Components

- convenient to resolve into 2 vectors
- at right angles
- in a “nice” coordinate system
- θ is between F_x and F from F_x

$$F_x = F \cos \theta$$

$$F_y = F \sin \theta$$

$$F = \sqrt{F_x^2 + F_y^2}$$

$$\tan \theta = \frac{F_y}{F_x}$$

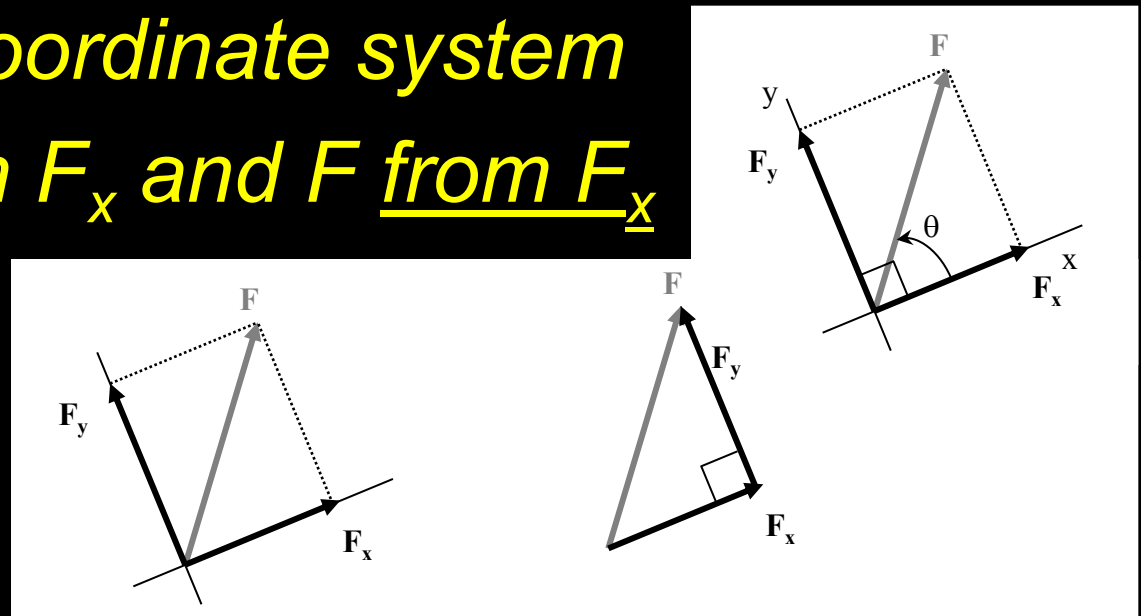

Trigonometry

- F_x is negative
 - 90° to 270°
- F_y is negative
 - 180° to 360°
- \tan is positive
 - quads I & III
- \tan is negative
 - quads II & IV

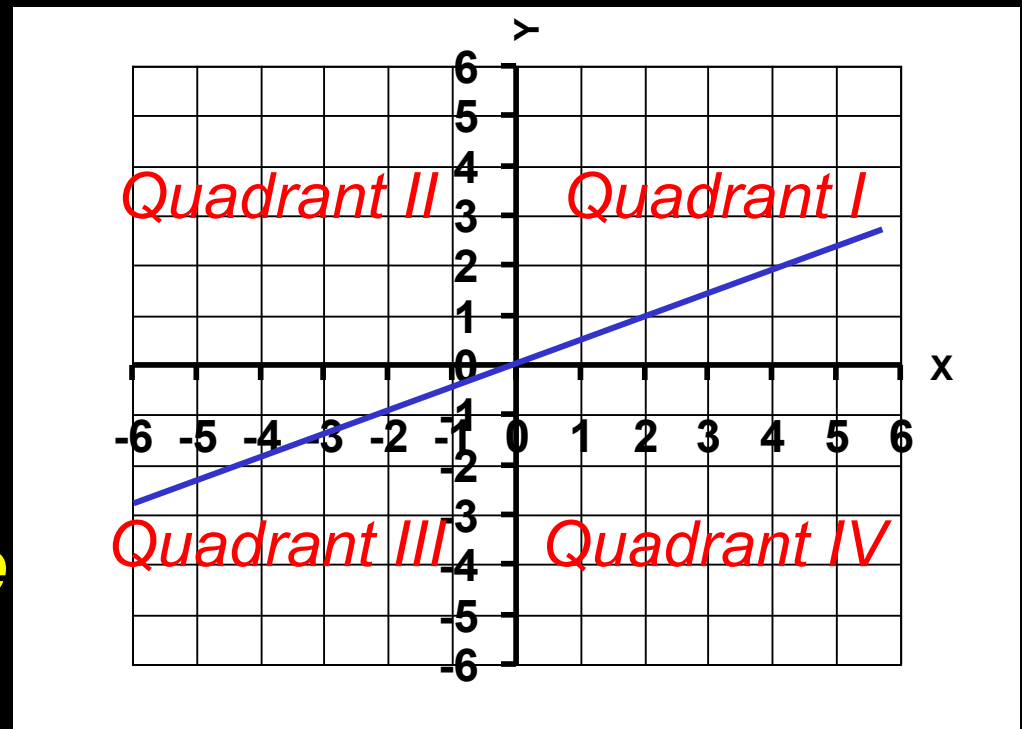

Component Addition

- find all x components
- find all y components
- find sum of x components, R_x (resultant)
- find sum of y components, R_y

$$R = \sqrt{R_x^2 + R_y^2}$$

$$\tan \theta = \frac{R_y}{R_x}$$

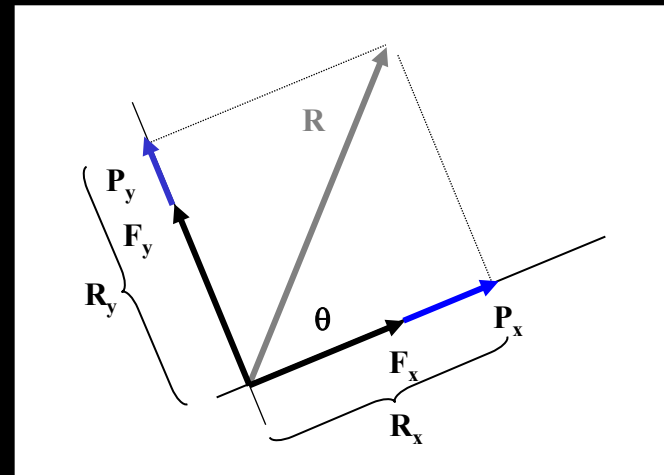

Alternative Trig for Components

- doesn't relate angle to axis direction
- ϕ is "small" angle between F and EITHER F_x or F_y
- no sign out of calculator!
- have to choose **RIGHT** trig function, resulting direction (sign) and component axis

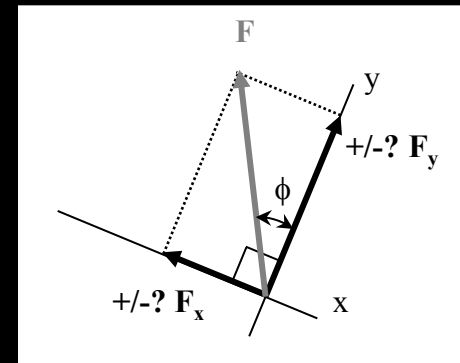

Friction

- *resistance to movement*
- *contact surfaces determine μ*
- *proportion of normal force (\perp)*
 - *opposite to slide direction*
 - *static > kinetic*

$$F = \mu N$$

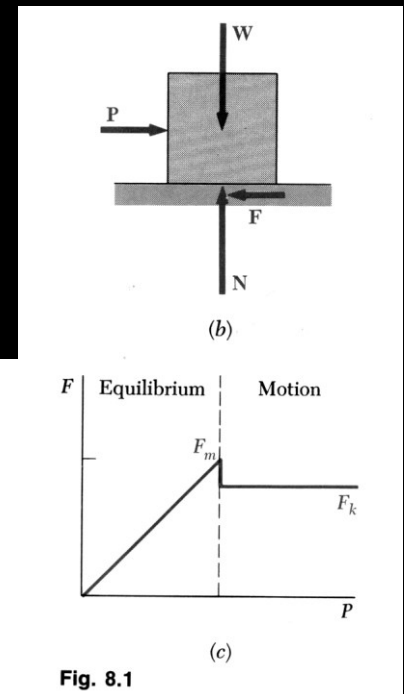
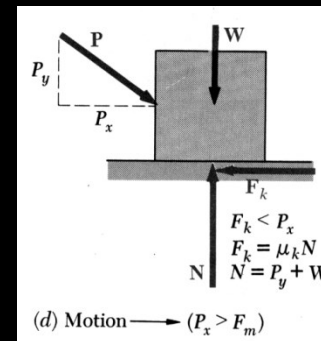

Cables

- *simple*
- *uses*
 - *suspension bridges*
 - *roof structures*
 - *transmission lines*
 - *guy wires, etc.*
- *have same tension all along*
- *can't stand compression*



<http://nisee.berkeley.edu/godden>

Cables Structures

- *use high-strength steel*
- *need*
 - *towers*
 - *anchors*
- *don't want movement*



<http://nisee.berkeley.edu/godden>

Cable Structures

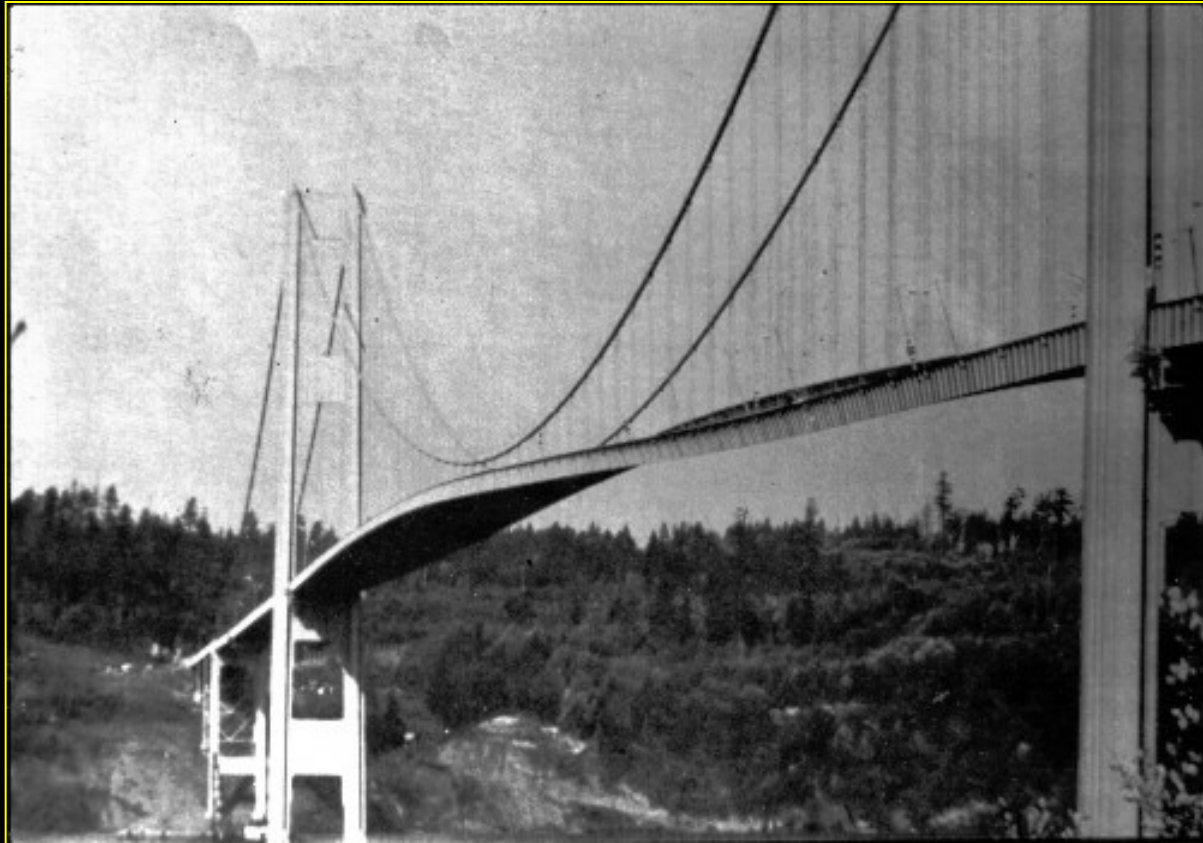

Cable Loads

- *straight line between forces*
- *with one force*
 - *concurrent*
 - *symmetric*

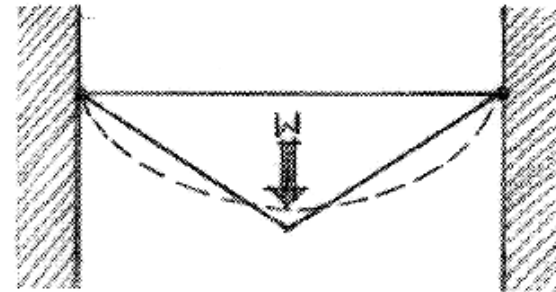
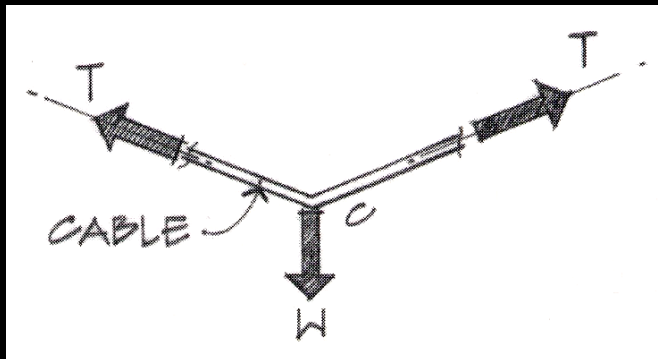

(a) *Simple concentrated load—triangle.*

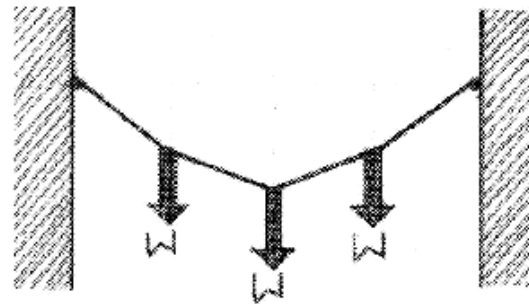

(b) *Several concentrated loads—polygon.*

Cable Loads

- *shape directly related to the distributed load*

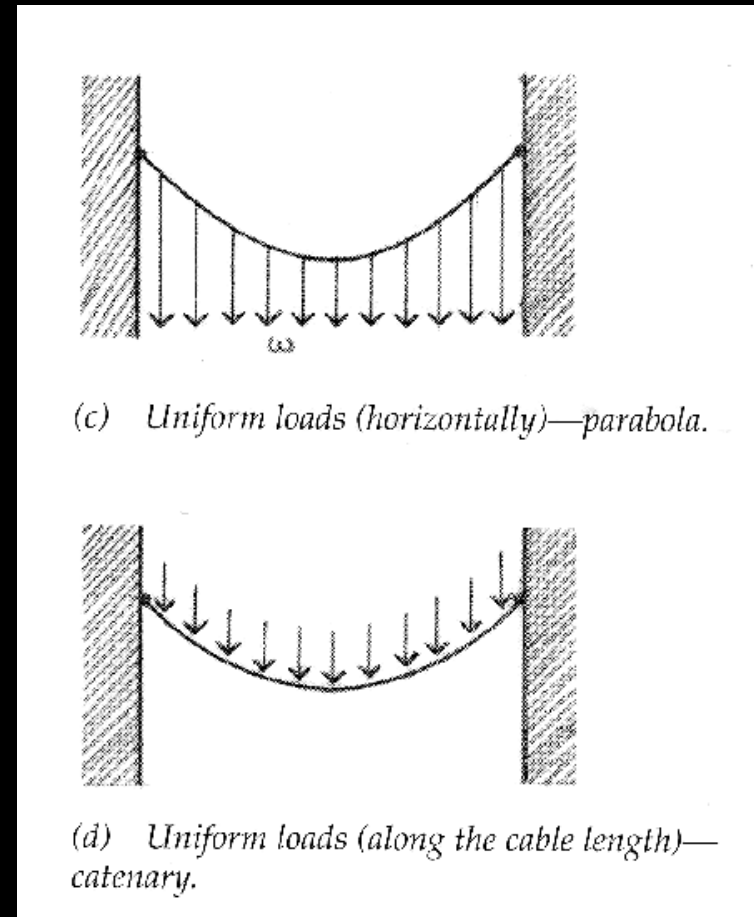
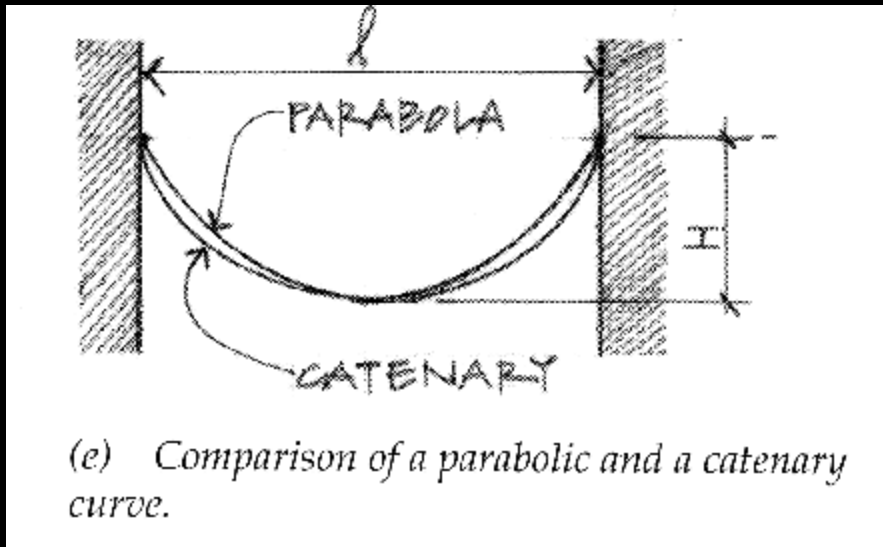

Cable-Stayed Structures

- *diagonal cables support horizontal spans*
- *typically symmetrical*
- *Patcenter,
Rogers 1986*



Patcenter, Rogers 1986

- *column free space*
- *roof suspended*
- *solid steel ties*
- *steel frame supports masts*

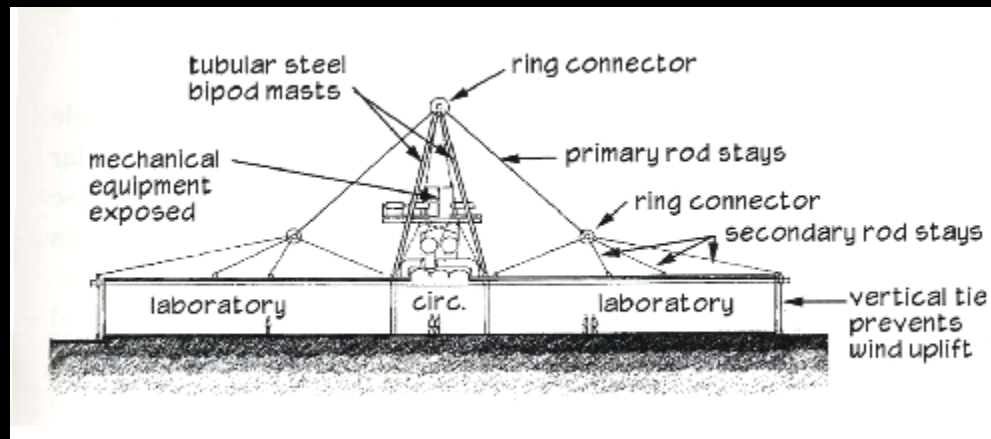

Patcenter, Rogers 1986

- *dashes – cables pulling*

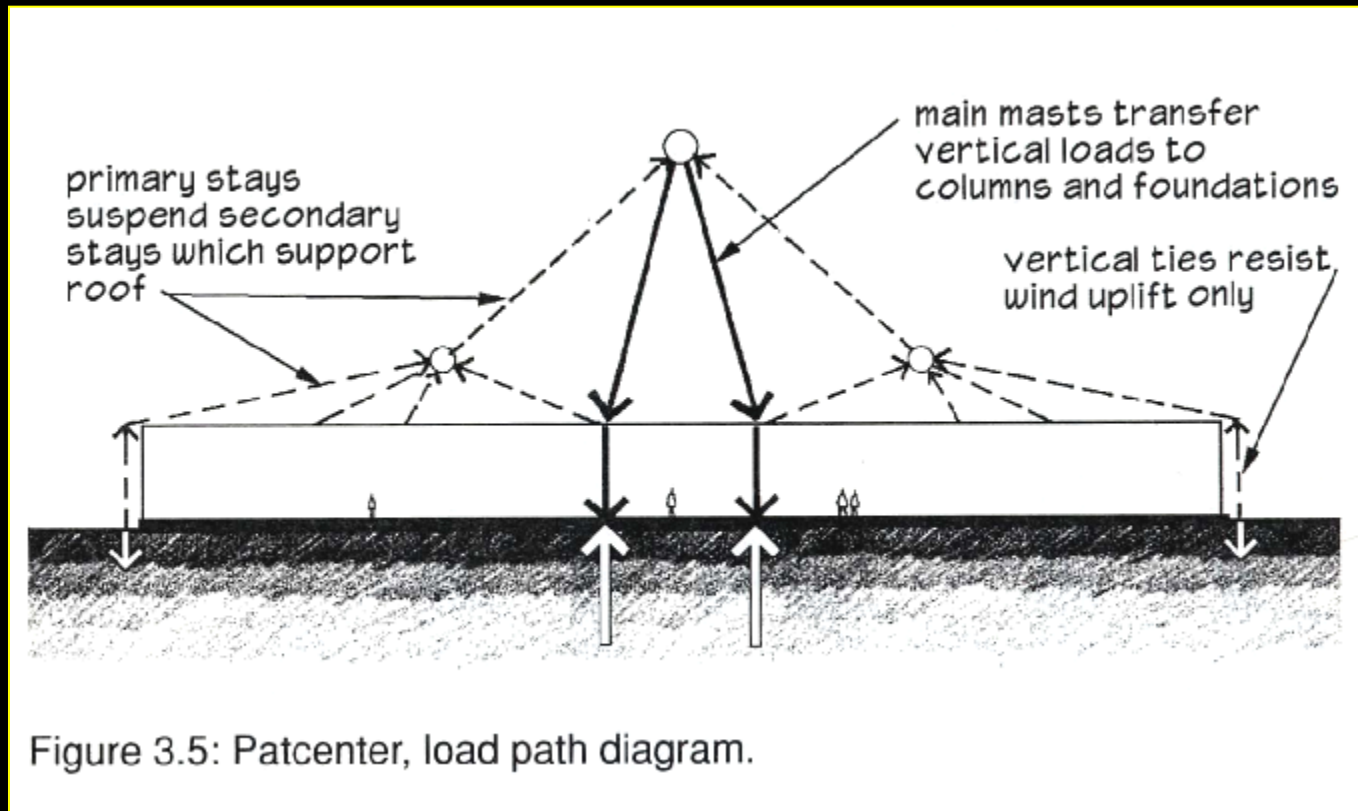

Moments

- *forces have the tendency to make a body rotate about an axis*

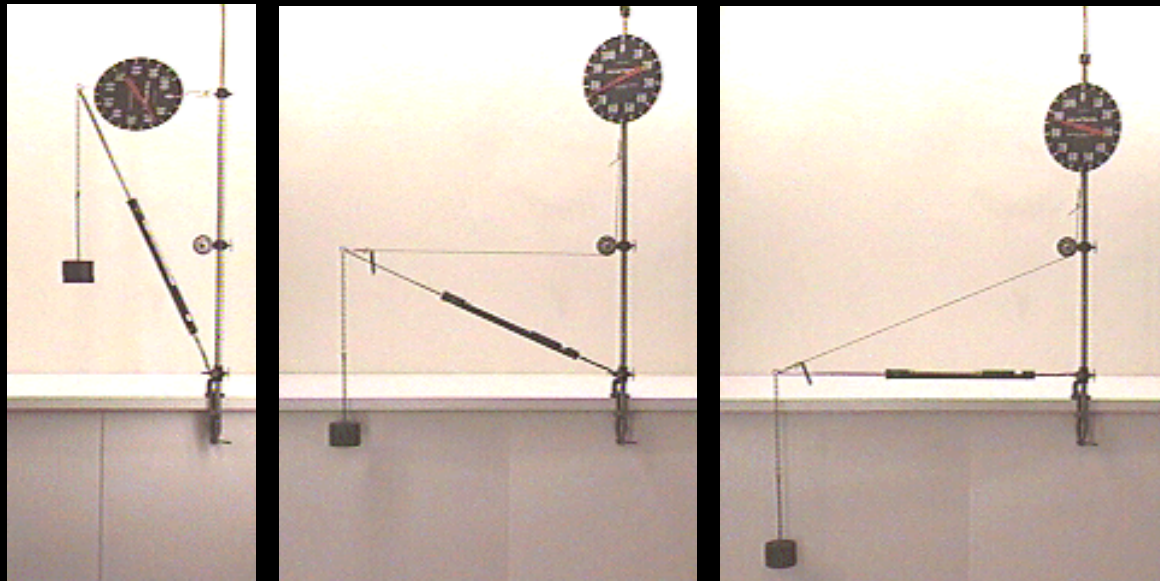

<http://www.physics.umd.edu>

– *same translation but different rotation*

Moments

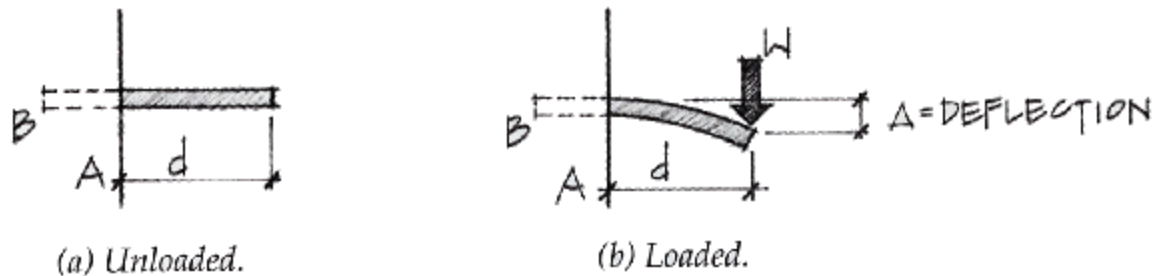

Figure 2.33 Moment on a cantilever beam.

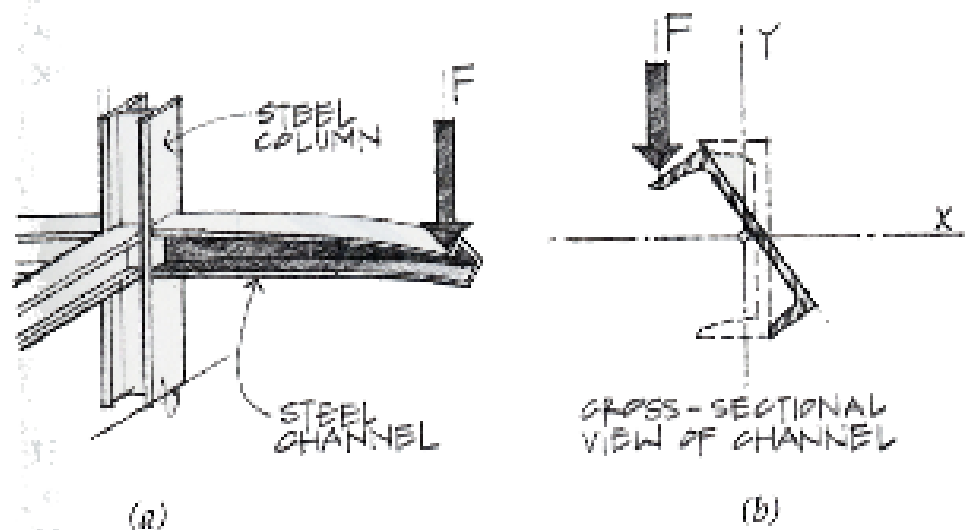
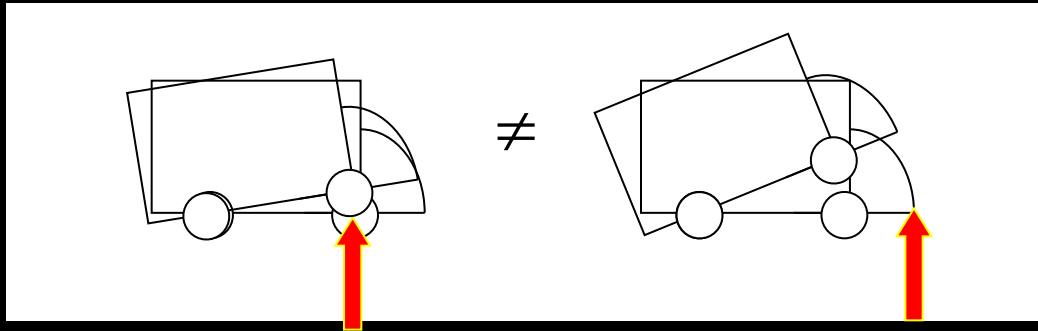

Figure 2.34 An example of torsion on a cantilever beam.

Moments

- *a force acting at a different point causes a different moment:*



Moments

- *defined by magnitude and direction*
- *units: N·m, k·ft*
- *direction:*
 - + *ccw (right hand rule)*
 - *cw*

- *value found from F and \perp distance*

$$M = F \cdot d$$

- *d also called “lever” or “moment” arm*

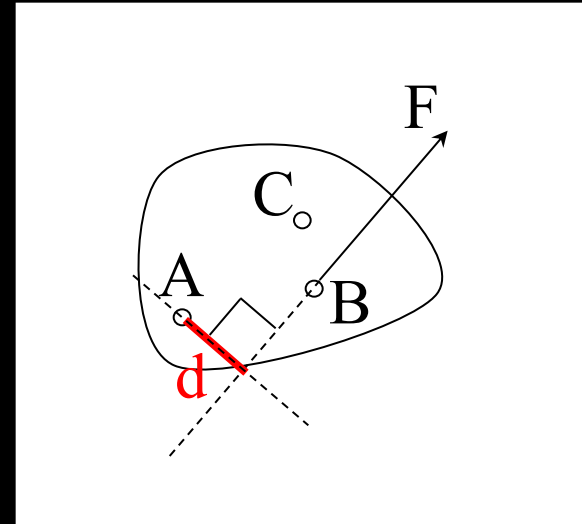

Moments

- with same F :

$$M_A = F \cdot d_1 < M_A = F \cdot d_2$$

(bigger)

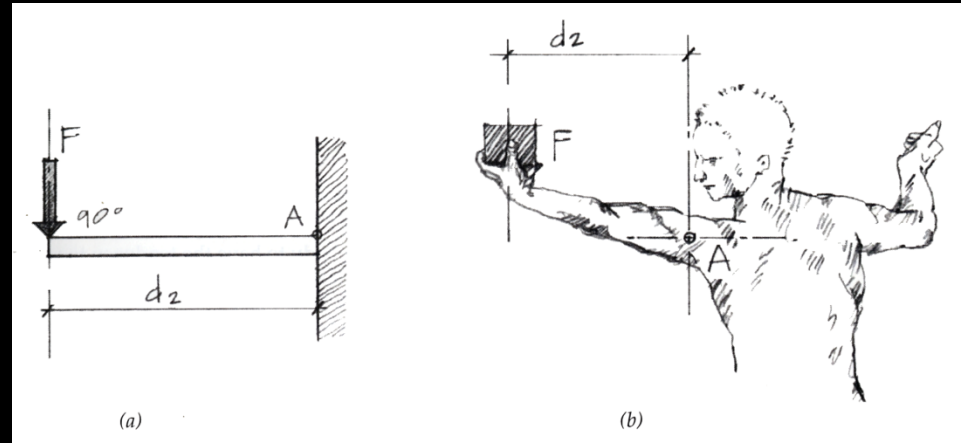
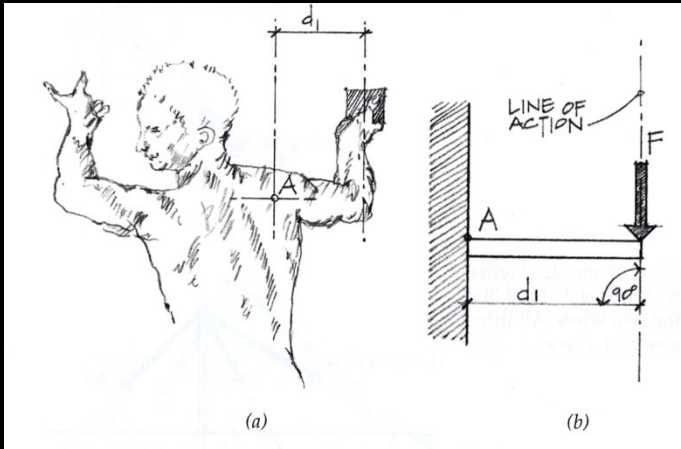

Moments

- *additive with sign convention*
- *can still move the force along the line of action*

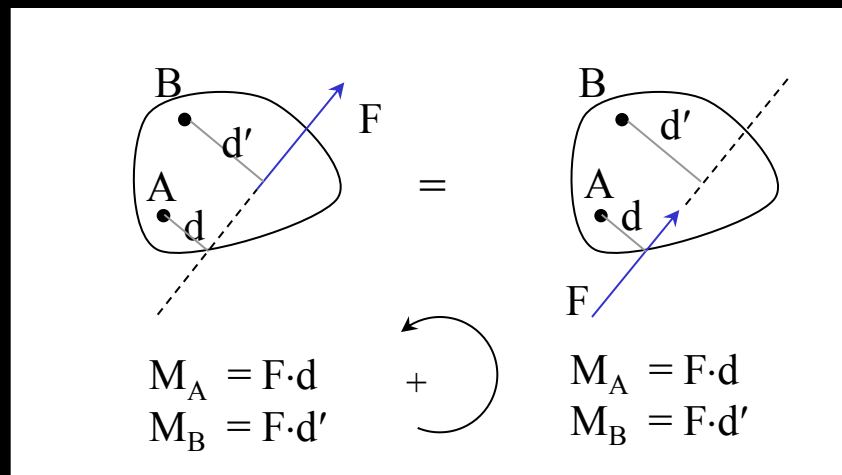

Moments

- *Varignon's Theorem*
 - *resolve a force into components at a point and finding perpendicular distances*
 - *calculate sum of moments*
 - *equivalent to original moment*
- *makes life easier!*
 - *geometry*
 - *when component runs through point, $d=0$*

Moments of a Force

- *moments of a force*
 - *introduced in Physics as “Torque Acting on a Particle”*
 - *and used to satisfy rotational equilibrium*

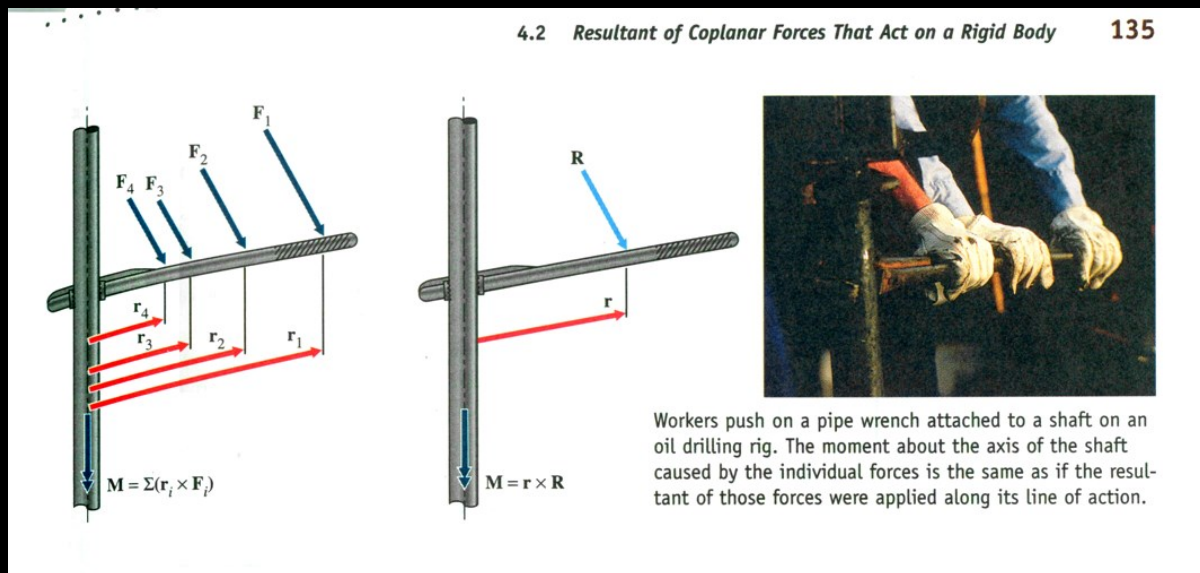

Physics and Moments of a Force

- *my Physics book:*

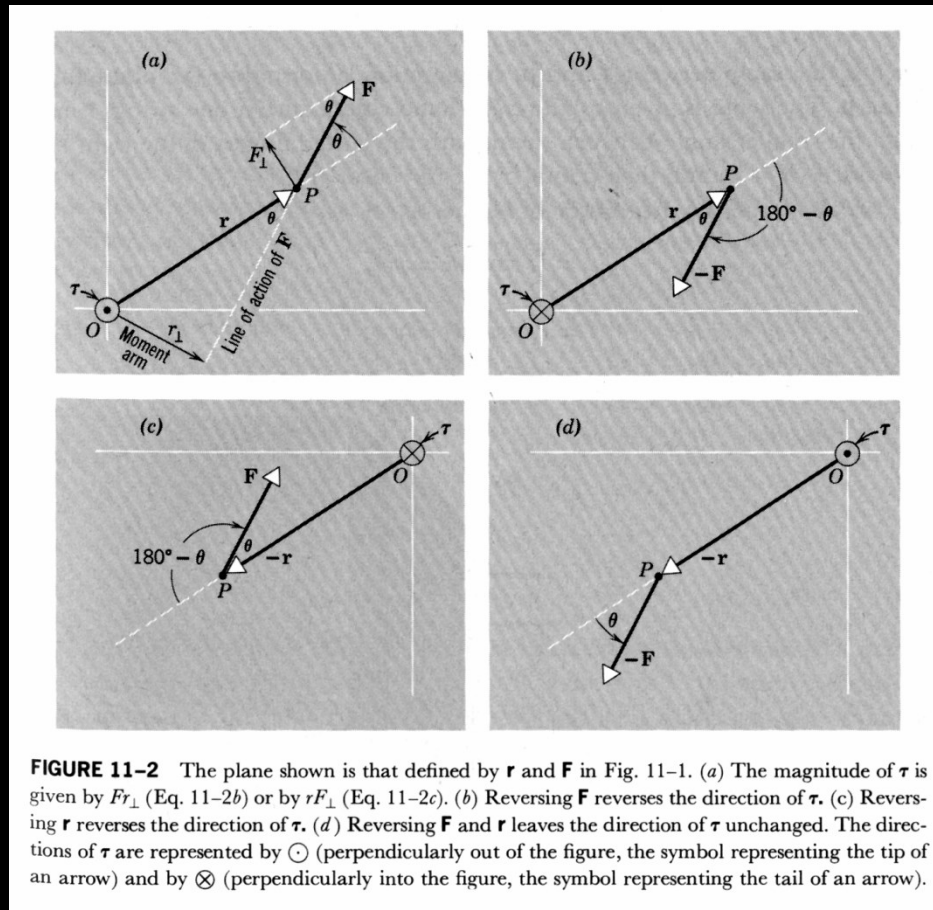

Moment Couples

- 2 forces
 - same size
 - opposite direction
 - distance d apart
 - CW or CCW

$$M = F \cdot d$$

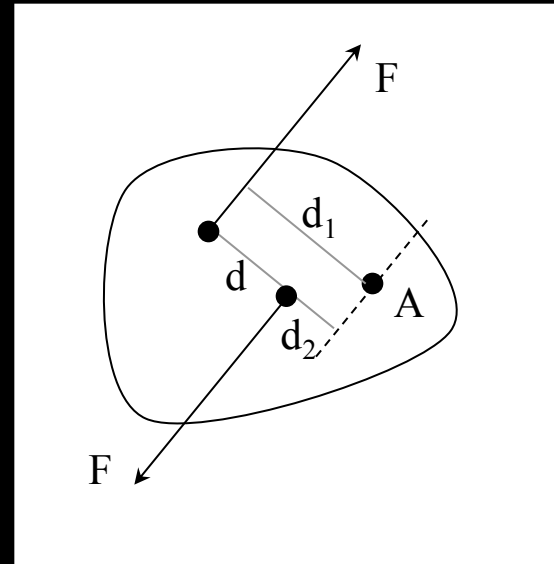

- not dependant on point of application

$$M = F \cdot d_1 - F \cdot d_2$$

Moment Couples

- *equivalent couples*
 - *same magnitude and direction*
 - *F & d may be different*

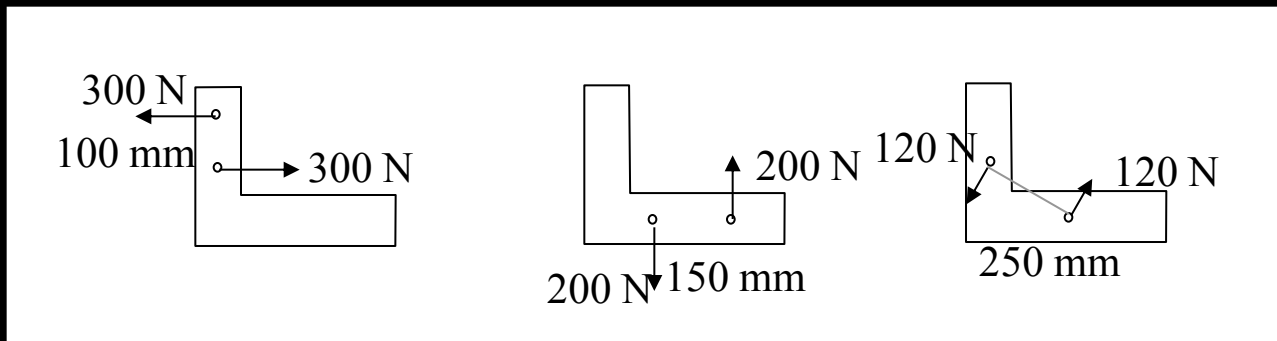

Moment Couples

- *added just like moments caused by one force*
- *can replace two couples with a single couple*

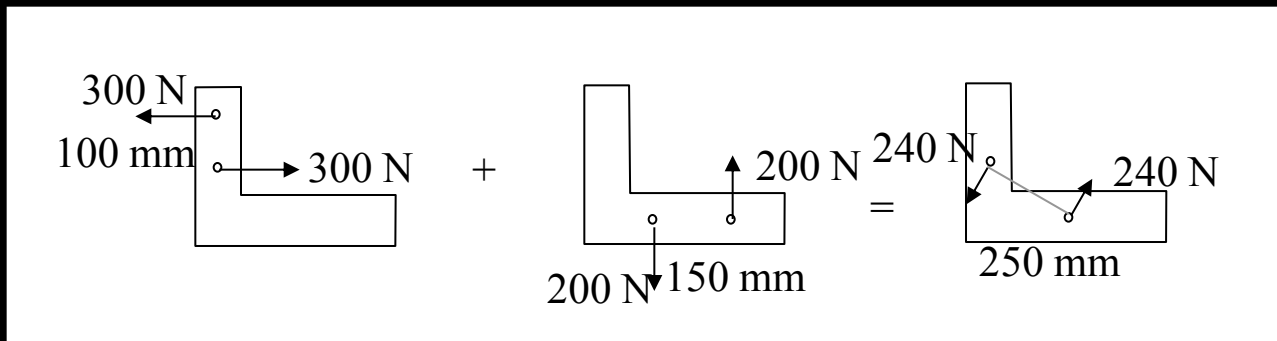

Moment Couples

- moment couples in structures

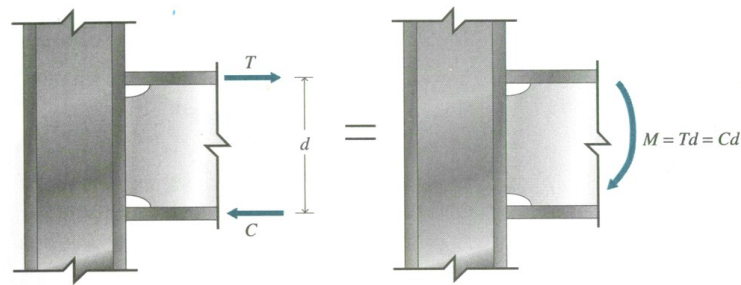

The flanges of a steel beam are welded to the flange of a column. Equal and opposite forces T and C in the beam flanges form a couple with moment M that is transferred into the column.

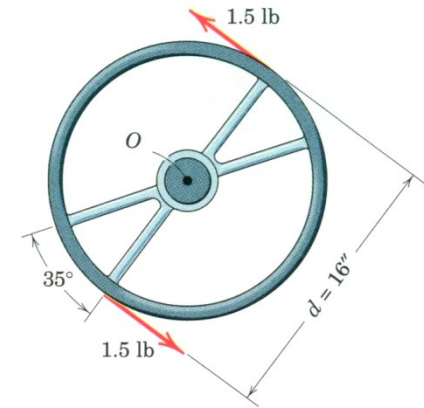

Equivalent Force Systems

- *two forces at a point is equivalent to the resultant at a point*
- *resultant is equivalent to two components at a point*
- *resultant of equal & opposite forces at a point is zero*
- *put equal & opposite forces at a point (sum to 0)*
- *transmission of a force along action line*

Force-Moment Systems

- *single force causing a moment can be replaced by the same force at a different point by providing the moment that force caused*

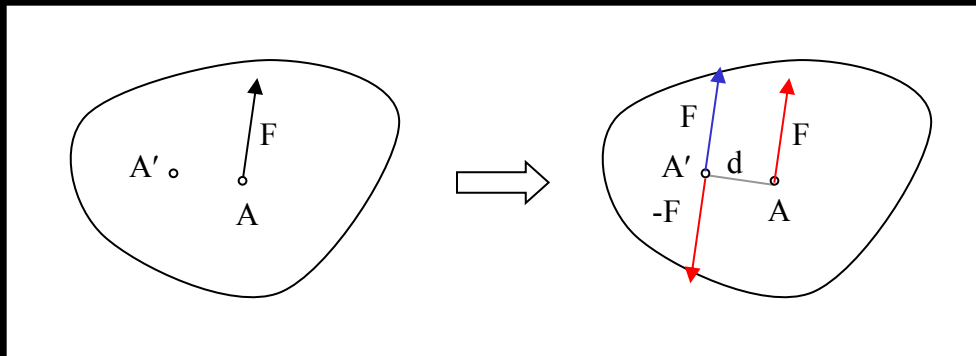

- *moments are shown as arched arrows*

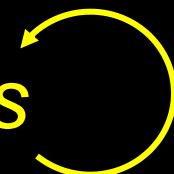

Force-Moment Systems

- a force-moment pair can be replaced by a force at another point causing the original moment

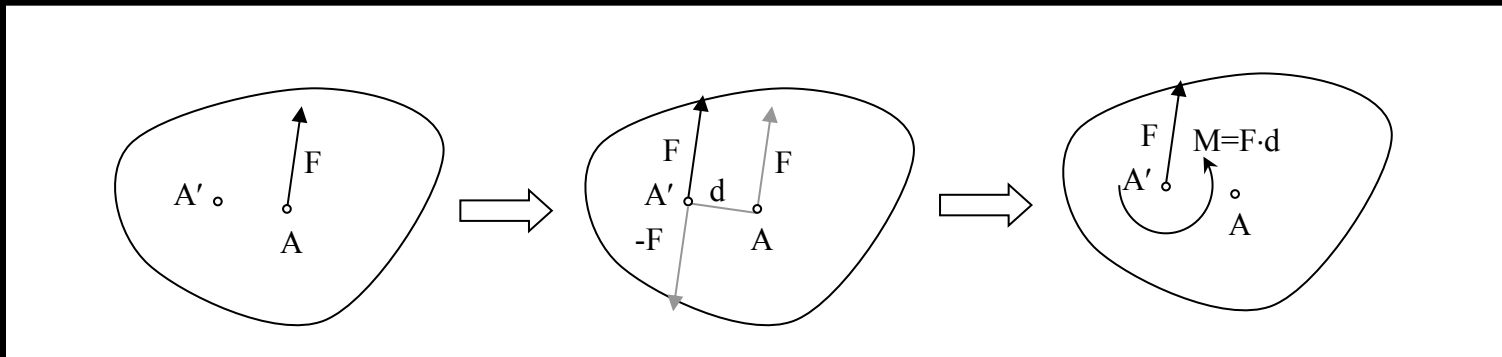

Parallel Force Systems

- forces are in the same direction
- can find resultant force
- need to find location for equivalent moments

