

Design of Isolated Square and Rectangular Footings (ACI 318-02)

Notation:

a	= equivalent square column size in spread footing design	l_s	= lap splice length in concrete design
	= depth of the effective compression block in a concrete beam	L	= name for length or span length
A_g	= gross area, equal to the total area ignoring any reinforcement	L_m	= projected length for bending in concrete footing design
A_{req}	= area required to satisfy allowable stress	L'	= length of the one-way shear area in concrete footing design
A_s	= area of steel reinforcement in concrete design	M_n	= nominal flexure strength with the steel reinforcement at the yield stress and concrete at the concrete design strength for reinforced concrete flexure design
A_1	= area of column in spread footing design	M_u	= maximum moment from factored loads for LRFD beam design
A_2	= projected bearing area of column load in spread footing design	P	= name for axial force vector
b	= rectangular column dimension in concrete footing design	P_{dowels}	= nominal capacity of dowels from concrete column to footing in concrete design
	= width, often cross-sectional	P_D	= dead load axial force
b_f	= width of the flange of a steel or cross section	P_L	= live load axial force
b_o	= perimeter length for two-way shear in concrete footing design	P_n	= nominal column or bearing load capacity in concrete design
B	= spread footing dimension in concrete design	P_u	= factored axial force
	= dimension of a steel base plate for concrete footing design	$q_{allowable}$	= allowable soil bearing stress in allowable stress design
B_s	= width within the longer dimension of a rectangular spread footing that reinforcement must be concentrated within for concrete design	q_{net}	= net allowed soil bearing pressure
c	= rectangular column dimension in concrete footing design	q_u	= factored soil bearing capacity in concrete footing design from load factors
C	= dimension of a steel base plate for concrete footing design	V_c	= shear force capacity in concrete
d	= effective depth from the top of a reinforced concrete member to the centroid of the tensile steel	V_n	= nominal shear force capacity
d_b	= bar diameter of a reinforcing bar	V_{u1}	= maximum one-way shear from factored loads for LRFD beam design
d_f	= depth of a steel column flange (wide flange section)	V_{u2}	= maximum two-way shear from factored loads for LRFD beam design
f'_c	= concrete design compressive stress	β_c	= ratio of long side to short side of the column in concrete footing design
f_y	= yield stress or strength	ϕ	= resistance factor
h_f	= height of a concrete spread footing	γ_c	= density or unit weight of concrete
l_d	= development length for reinforcing steel	γ_s	= density or unit weight of soil
l_{dc}	= development length for column	ρ	= reinforcement ratio in concrete beam design = A_s/bd
		v_c	= shear strength in concrete design

NOTE: This procedure assumes that the footing is concentrically loaded and carries no moment so that the soil pressure may be assumed to be uniformly distributed on the base.

1) Find service dead and live column loads:

P_D = Service dead load from column

P_L = Service live load from column

$P = P_D + P_L$ (typically – see ACI 9.2)

2) Find design (factored) column load, P_u :

$$P_u = 1.2P_D + 1.6P_L$$

3) Find an approximate footing depth, h_f :

$h_f = d + 4"$ and is usually in multiples of 2, 4 or 6 inches.

a) For rectangular columns $4d^2 + 2(b + c)d = \frac{P_u}{\phi v_c}$

b) For round columns $d^2 + ad = \frac{P_u}{\phi v_c}$ $a = \sqrt{\frac{\pi d^2}{4}}$

where: a is the equivalent square column size

$$v_c = 4\sqrt{f'_c} \text{ for two-way shear}$$

$$\phi = 0.75 \text{ for shear}$$

4) Find net allowable soil pressure, q_{net} :

By neglecting the weight of any additional top soil added, the net allowable soil pressure takes into account the change in weight when soil is removed and replaced by concrete:

$$q_{net} = q_{allowable} - h_f(\gamma_c - \gamma_s)$$

where γ_c is the unit weight of concrete (typically 150 lb/ft³)

and γ_s is the unit weight of the displaced soil

5) Find required area of footing base and establish length and width:

$$A_{req} \geq \frac{P}{q_{net}}$$

For square footings choose $B \geq \sqrt{A_{req}}$

For rectangular footings choose $B \times L \geq A_{req}$

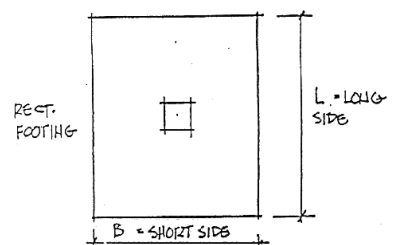
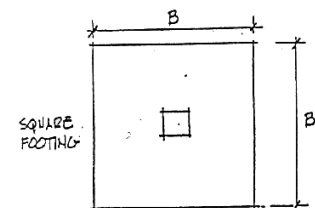
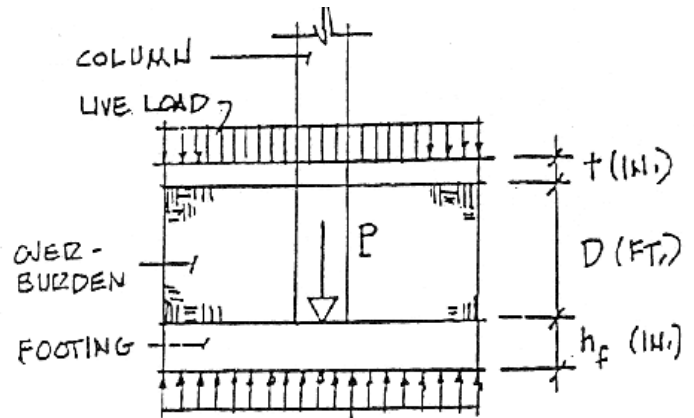
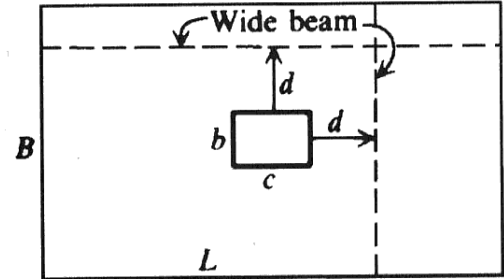

6) Check transfer of load from column to footing: ACI 15.8

a) Find load transferred by bearing on concrete in column: **ACI 10.17**

basic: $\phi P_n = \phi 0.85 f'_c A_1$ where $\phi = 0.65$ and A_1 is the area of the column

with confinement: $\phi P_n = \phi 0.85 f'_c A_1 \sqrt{\frac{A_2}{A_1}}$ where $\sqrt{\frac{A_2}{A_1}}$ cannot exceed 2.

IF the column concrete strength is lower than the footing, calculate ϕP_n for the column too.

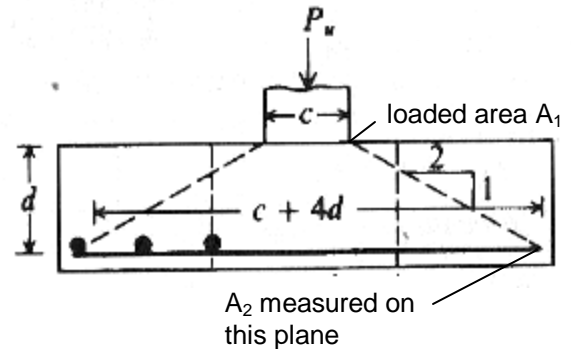

b) Find load to be transferred by dowels:

$$\phi P_{dowels} = P_u - \phi P_n$$

IF $\phi P_n \geq P_u$ only nominal dowels are required.

c) Find required area of dowels and choose bars

Req. dowel $A_s = \frac{\phi P_{dowels}}{\phi f_y}$ where $\phi = 0.65$ and f_y is the reinforcement grade

Choose dowels to satisfy the required area and nominal requirements:

- i) Minimum of 4 bars
- ii) Minimum $A_s = 0.005 A_g$ **ACI 15.8.2.1**
where A_g is the gross column area
- iii) 4 - #5 bars

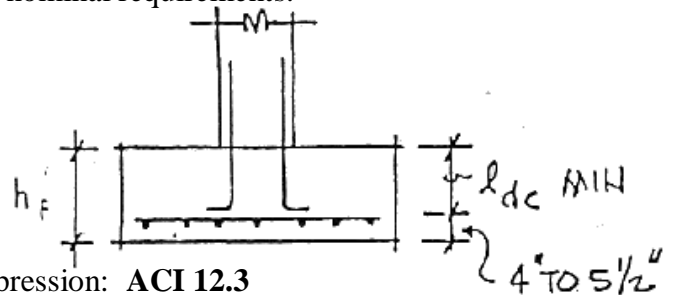

d) Check dowel embedment into footing for compression: **ACI 12.3**

$$l_{dc} = \frac{0.02 f_y d_b}{\sqrt{f'_c}} \text{ but not less than } 0.0003 f_y d_b \text{ or } 8'' \text{ where } d_b \text{ is the bar diameter}$$

NOTE: The footing must be deep enough to accept l_{dc} . Hooks are not considered effective in compression and are only used to support dowels during construction.

e) Find length of lapped splices of dowels with column bars: **ACI 12.16**

l_s is the largest of:

- i) larger of l_{dc} or $0.0005 f_y d_b$ (f_y of grade 60 or less)
of smaller bar $(0.0009 f_y - 24) d_b$ (f_y over grade 60)
- ii) l_{dc} of larger bar
- iii) not less than 12''

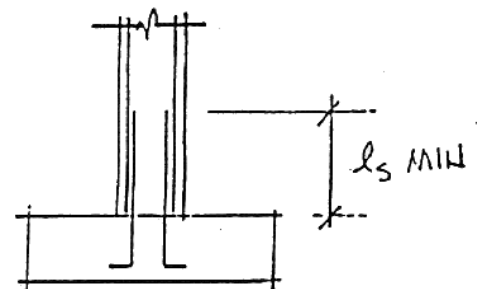

See **ACI 12.17.2** for possible reduction in l_s

7) Check two-way (slab) shear:

a) Find dimensions of loaded area:

- i) For concrete columns, the area coincides with the column area, if rectangular, or equivalent square area if circular (see 3)b))
- ii) For steel columns an equivalent loaded area whose boundaries are halfway between the faces of the steel column and the edges of the steel base plate is used: **ACI 15.4.2c.**

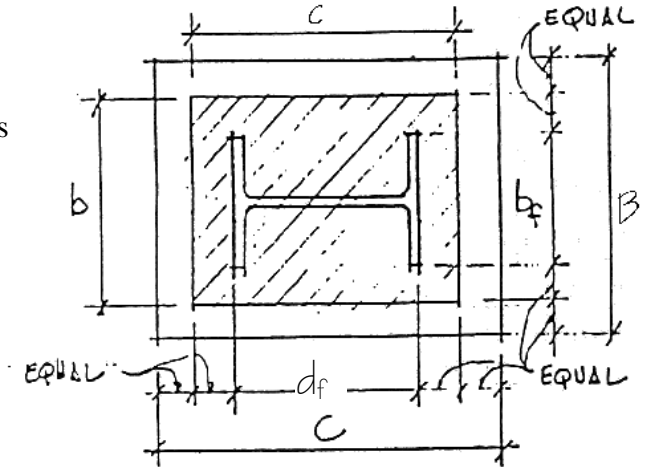

$$b = b_f + \frac{(B - b_f)}{2} \text{ where } b_f \text{ is the width of column flange and } B \text{ is base plate side}$$

$$c = d_f + \frac{(C - d_f)}{2} \text{ where } d_f \text{ is the depth of column flange and } C \text{ is base plate side}$$

b) Find shear perimeter: **ACI 11.12.1.2**

Shear perimeter is located at a distance of $d/2$ outside boundaries of loaded area and

$$\text{length is } b_o = 2(c + d) + 2(b + d)$$

(average $d = h_f - 3 \text{ in. cover} - 1 \text{ assumed bar diameter}$)

c) Find factored net soil pressure, q_u :

$$q_u = \frac{P_u}{B^2} \text{ or } \frac{P_u}{B \times L}$$

d) Find total shear force for two-way shear, V_{u2} :

$$V_{u2} = P_u - q_u(c + d)(b + d)$$

e) Compare V_{u2} to two-way capacity, ϕV_n :

$$V_{u2} \leq \phi \left(2 + \frac{4}{\beta_c} \right) \sqrt{f'_c} b_o d \leq \phi 4 \sqrt{f'_c} b_o d \text{ ACI 11.12.2.1}$$

where $\phi = 0.75$ and β_c is the ratio of long side to short side of the column

NOTE: This should be acceptable because the initial footing size was chosen on the basis of two-way shear limiting. If it is not acceptable, increase h_f and repeat steps starting at b).

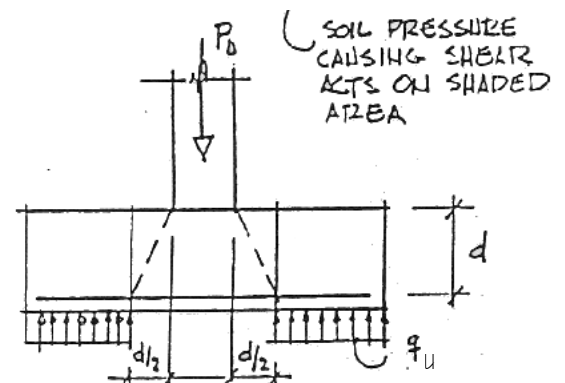
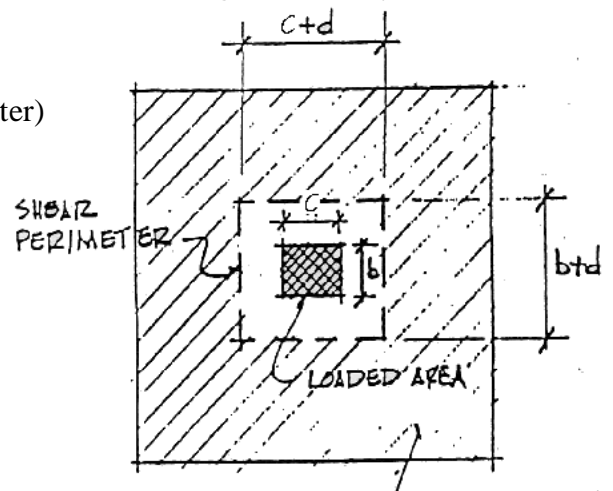

8) Check one-way (beam) shear:

The critical section for one-way shear extends across the width of the footing at a distance d from the face of the loaded area (see 7)a) for loaded area). The footing is treated as a cantilevered beam. **ACI 11.12.1.1**

a) Find projection, L' :

i) For square footing:

$$L' = \frac{B}{2} - (d + \frac{b}{2})$$

where b is the smaller dim. of the loaded area

ii) For rectangular footings:

$$L' = \frac{L}{2} - (d + \frac{\bullet}{2})$$

where \bullet is the dim. parallel to the long side of the footing

b) Find total shear force on critical section, V_{u1} :

$$V_{u1} = BL'q_u$$

c) Compare V_{u1} to one-way capacity, ϕV_n :

$$V_{u1} \leq \phi 2\sqrt{f'_c}Bd \quad \text{ACI 11.12.3.1} \quad \text{where } \phi = 0.75$$

NOTE: If it is not acceptable, increase h_f .

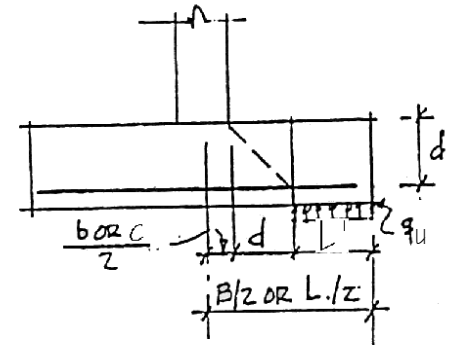
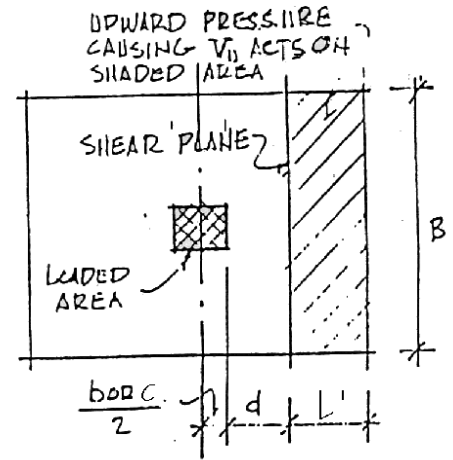

9) Check for bending stress and design reinforcement:

Square footings may be designed for moment in one direction and the same reinforcing used in the other direction. For rectangular footings the moment and reinforcing must be calculated separately in each direction. The critical section for moment extends across the width of the footing at the face of the loaded area. **ACI 15.4.1, 15.4.2.**

a) Find projection, L_m :

$$L_m = \frac{B}{2} - \frac{\bullet}{2}$$

where \bullet is the smaller dim. of column for a square footing. For a rectangular footing, use the value perpendicular to the critical section.

b) Find total moment, M_u , on critical section:

$$M_u = q_u \frac{BL_m^2}{2} \quad (\text{find both ways for a rectangular footing})$$

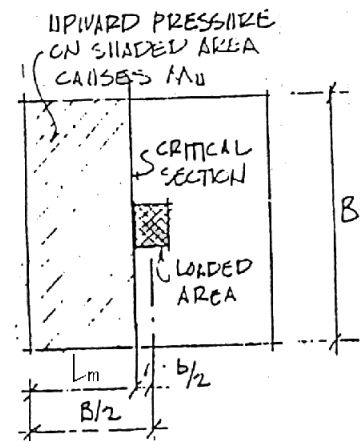

c) Find required A_s :

$$R_n = \frac{M_n}{bd^2} = \frac{M_u}{\phi bd^2}, \text{ where } \phi = 0.9, \text{ and } \rho \text{ can be found}$$

from Figure 3.8.1 of Wang & Salmon.

or:

i) guess a

ii)
$$A_s = \frac{0.85 f_c' b a}{f_y}$$

iii) solve for $a = 2 \left(d - \frac{M_u}{\phi A_s f_y} \right)$

iv) repeat from ii) until a converges, solve for A_s

Minimum A_s

= 0.0018bh Grade 60 for temperature and shrinkage control

= 0.002bh Grade 40 or 50

ACI 10.5.4 specifies the requirements of 7.12 must be met, and max. spacing of 18"

d) Choose bars:

For square footings use the same size and number of bars uniformly spaced in each direction (ACI 15.4.3). Note that required A_s must be furnished in each direction.

For rectangular footings bars in long direction should be uniformly spaced. In the short direction bars should be distributed as follows (ACI 15.4.4):

i) In a band of width B_s centered on column:

$$\# \text{ bars} = \frac{2}{L/B + 1} \cdot (\# \text{ bars in } B) \text{ (integer)}$$

ii) Remaining bars in short direction should be uniformly spaced in outer portions of footing.

e) Check development length:

Find required development length, l_d , in tension from handout or from equations in ACI 12.2. l_d must be less than $(L_m - 2'')$ (end cover). If not possible, use more bars of smaller diameter.

