

**ARCHITECTURAL STRUCTURES:  
FORM, BEHAVIOR, AND DESIGN**

**ARCH 331**

**DR. ANNE NICHOLS**

**SUMMER 2013**

**lecture  
fifteen**

**steel construction:  
materials & beams**



# Steel Beam Design

---

- *American Institute of Steel Construction*
  - *Manual of Steel Construction*
  - *ASD & LRFD*
  - *combined in 13<sup>th</sup> ed.*

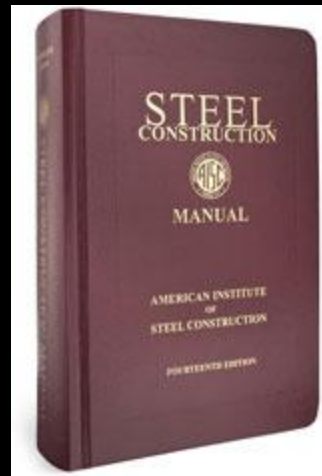

# Steel Materials

---

- *smelt iron ore*
- *add alloying elements*
- *heat treatments*
- *iron, carbon*
- *microstructure*

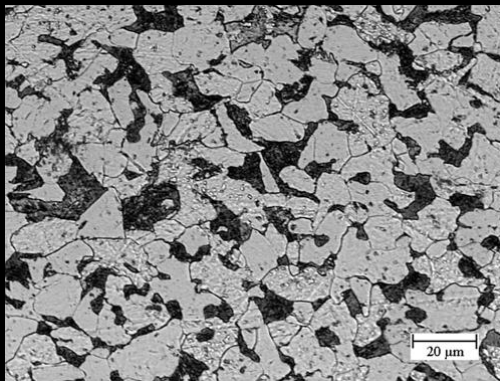

*A36 steel, JOM 1998*



*AISC*

# Steel Materials

---

- *cast into billets*
- *hot rolled*
- *cold formed*
- *residual stress*
- *corrosion-resistant “weathering” steels*
- *stainless*



Hot Rolled



Cold Formed

AISC

# Steel Materials

---

- *steel grades*
  - *ASTM A36 – carbon*
    - *plates, angles*
    - $F_y = 36 \text{ ksi}$  &  $F_u = 58 \text{ ksi}$
  - *ASTM A572 – high strength low-alloy*
    - *some beams*
    - $F_y = 60 \text{ ksi}$  &  $F_u = 75 \text{ ksi}$
  - *ASTM A992 – for building framing*
    - *most beams*
    - $F_y = 50 \text{ ksi}$  &  $F_u = 65 \text{ ksi}$

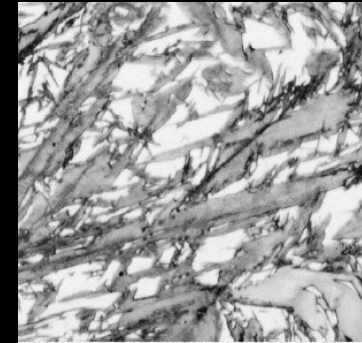

# Steel Properties

- *high strength to weight ratio*
- *elastic limit – yield ( $F_y$ )*
- *inelastic – plastic*
- *ultimate strength ( $F_u$ )*
- *ductile*
- *strength sensitive to temperature*
- *can corrode*
- *fatigue*

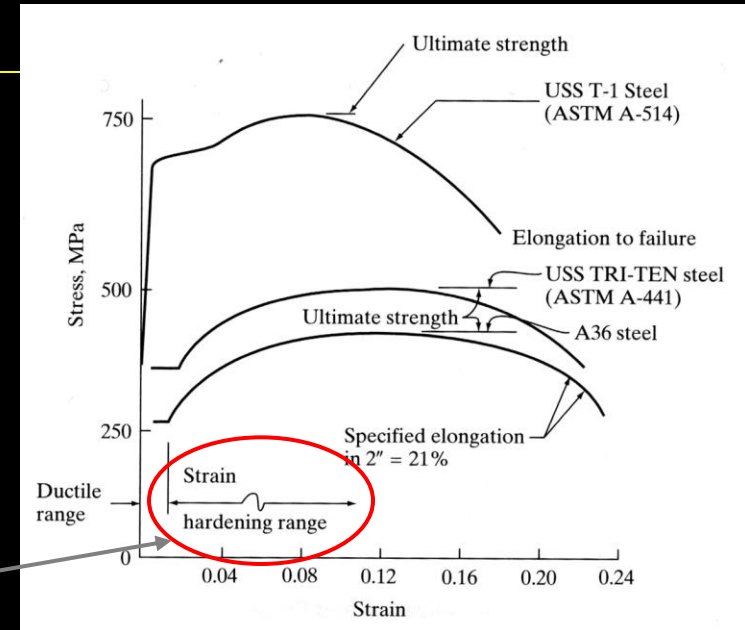

strain hardening

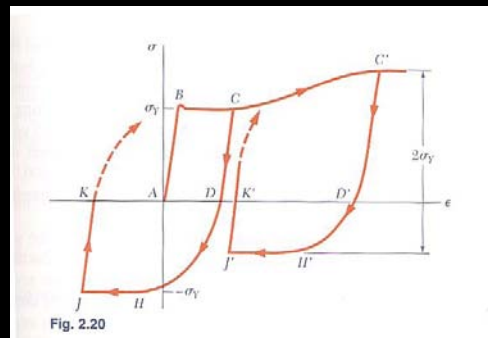

Winnipeg DOT

Su2013abn

# Structural Steel

- *standard rolled shapes (W, C, L, T)*
- *open web joists*
- *plate girders*
- *decking*

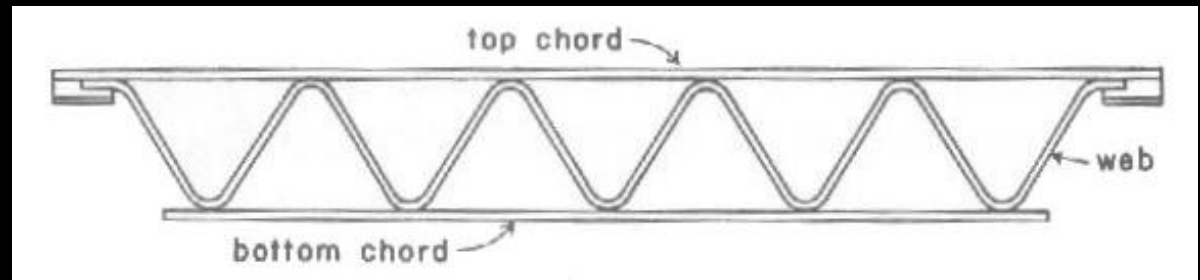
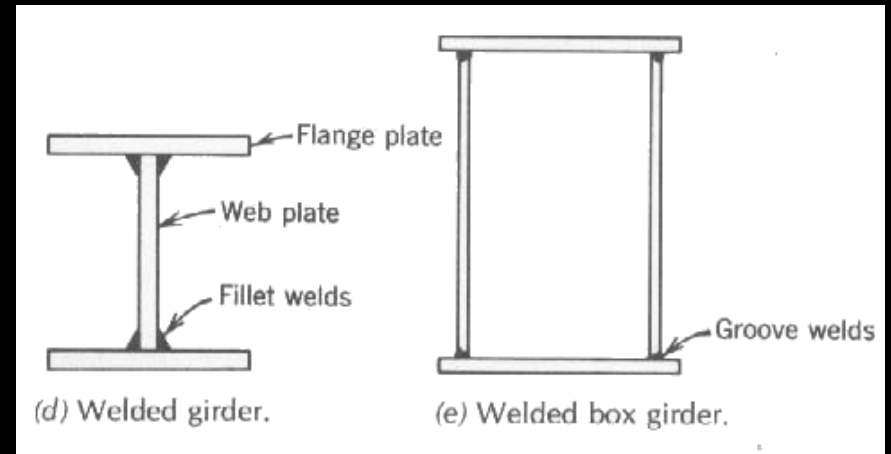
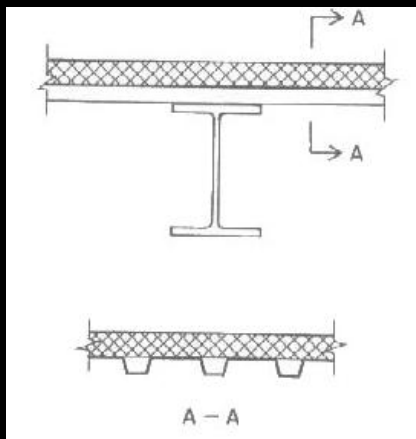

# Steel Construction

- *welding*
- *bolts*

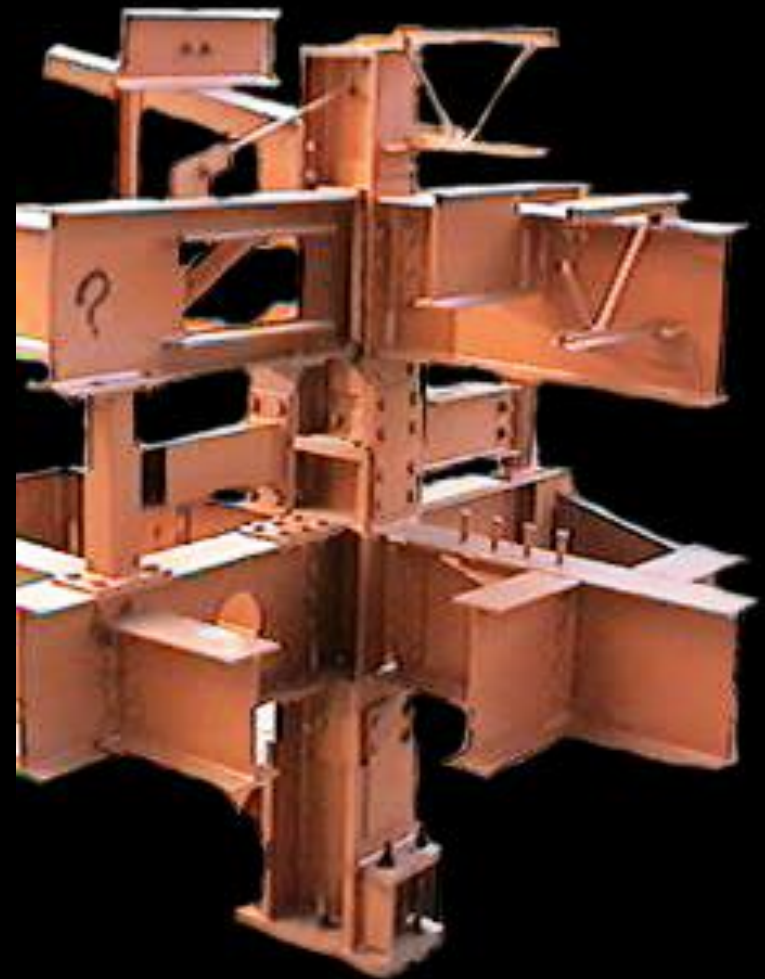
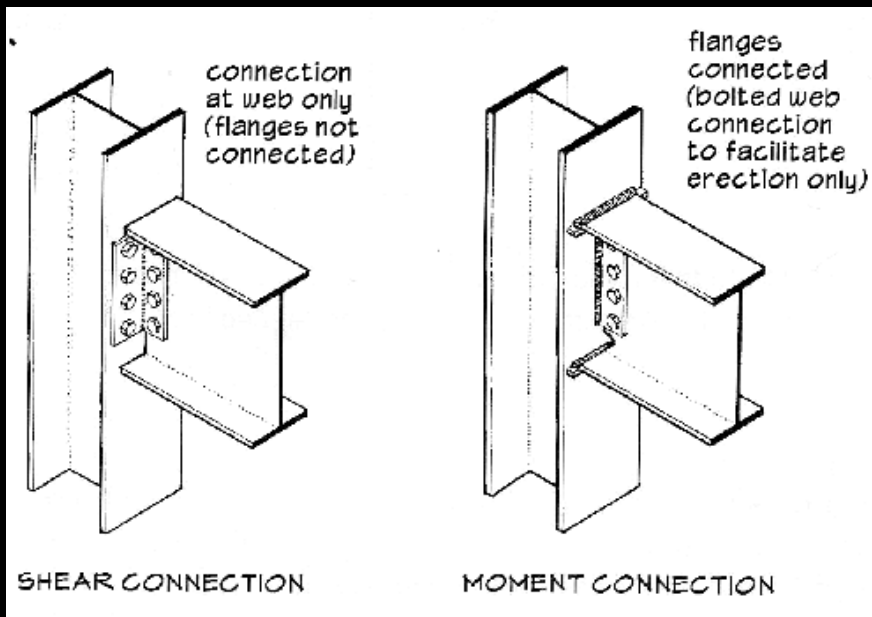



# Steel Construction

- *fire proofing*
  - *cementitious spray*
  - *encasement in gypsum*
  - *intumescent – expands with heat*
  - *sprinkler system*

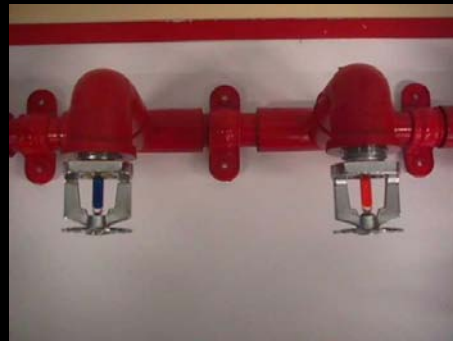
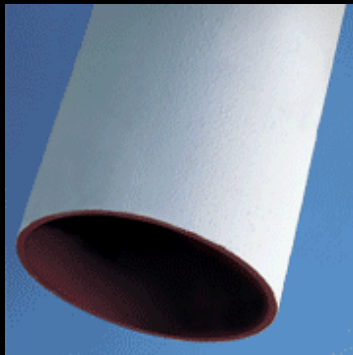

# Unified Steel Design

---

- ASD

$$R_a \leq \frac{R_n}{\Omega}$$

- bending (braced)  $\Omega = 1.67$
- bending (unbraced\*)  $\Omega = 1.67$
- shear  $\Omega = 1.67$
- shear (bolts & welds)  $\Omega = 2.00$
- shear (welds)  $\Omega = 2.00$

\* flanges in compression can buckle

# Unified Steel Design

- *braced vs. unbraced*

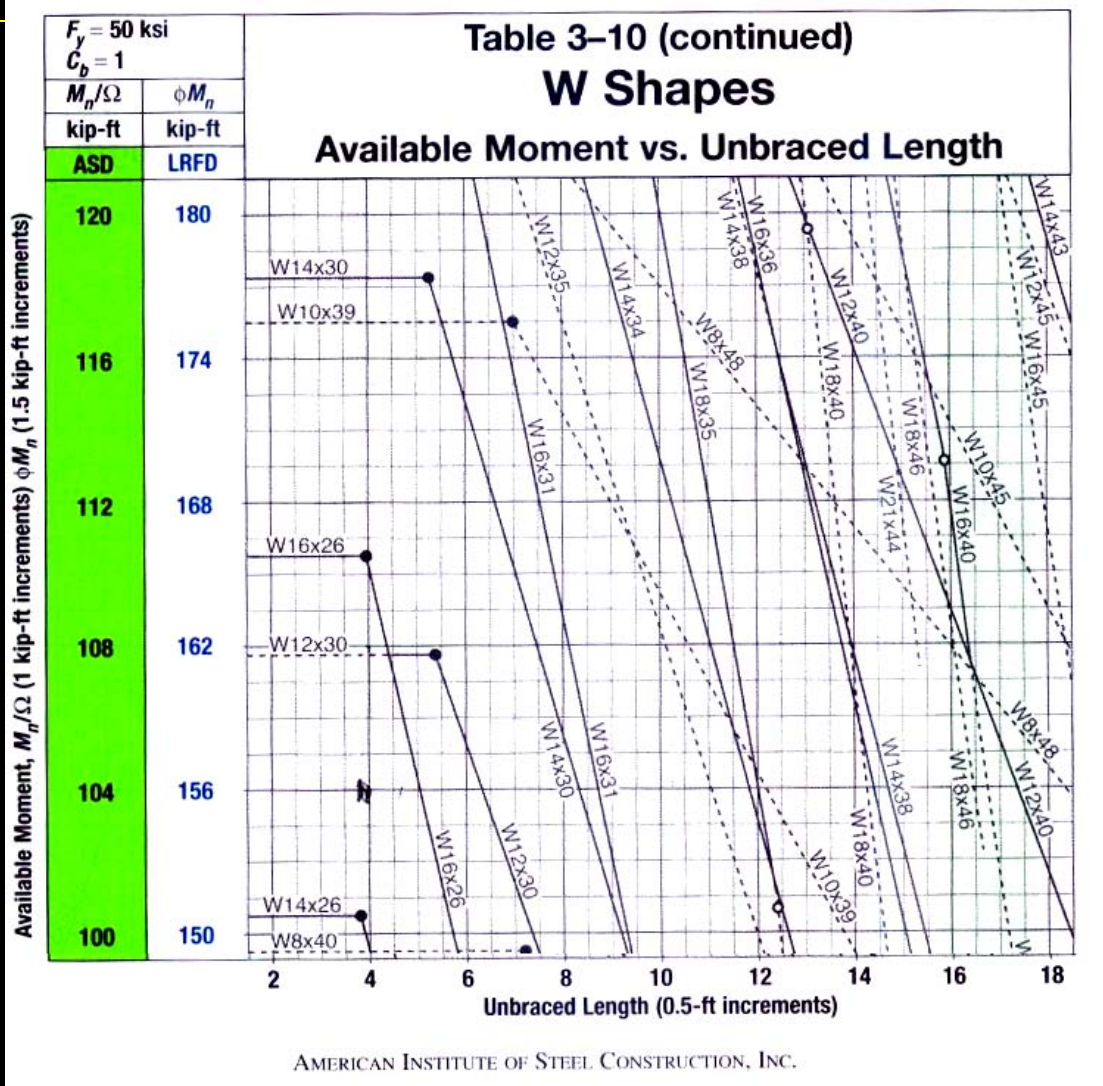

# LRFD

---

- *loads on structures are*
  - *not constant*
  - *can be more influential on failure*
  - *happen more or less often*
  - *UNCERTAINTY*

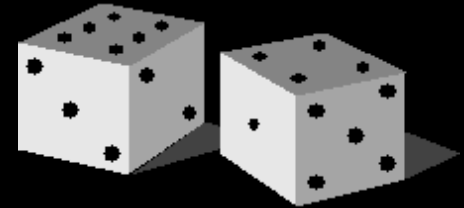

$$R_u = \gamma_D R_D + \gamma_L R_L \leq \phi R_n$$

$\phi$  - *resistance factor*

$\gamma$  - *load factor for (D)ead & (L)ive load*

# LRFD Steel Beam Design

- limit state is yielding all across section
- outside elastic range
- load factors & resistance factors

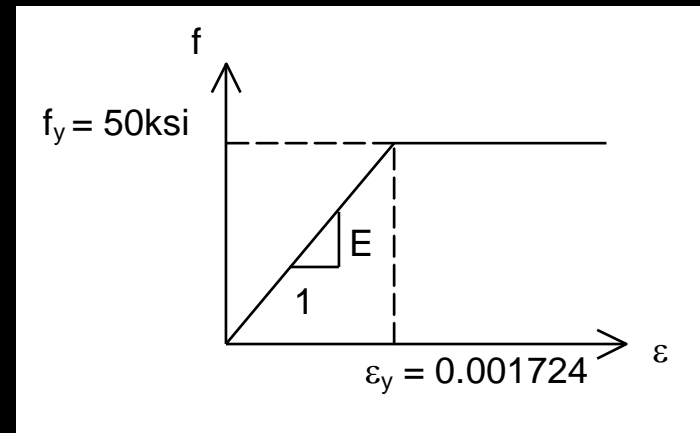
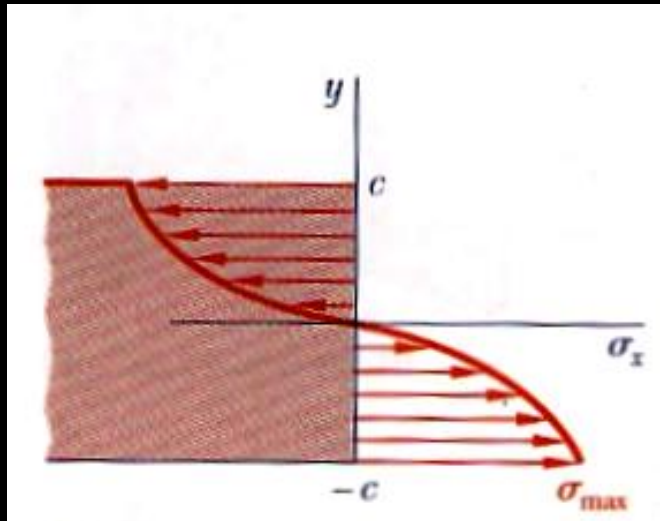

# LRFD Load Combinations

- $1.4D$
- $1.2D + 1.6L + 0.5(L_r \text{ or } S \text{ or } R)$
- $1.2D + 1.6(L_r \text{ or } S \text{ or } R) + (L \text{ or } 0.5W)$
- $1.2D + 1.0W + L + 0.5(L_r \text{ or } S \text{ or } R)$
- $1.2D + 1.0E + L + 0.2S$
- $0.9D + 1.0W$
- $0.9D + 1.0E$ 
  - $F$  has same factor as  $D$  in 1-5 and 7
  - $H$  adds with 1.6 and resists with 0.9 (permanent)

# Beam Design Criteria (revisited)

- *strength design*
  - *bending stresses predominate*
  - *shear stresses occur*
- *serviceability*
  - *limit deflection*
  - *stability*
- *superpositioning*
  - *use of beam charts*
  - *elastic range only!*
  - *“add” moment diagrams*
  - *“add” deflection CURVES (not maximums)*

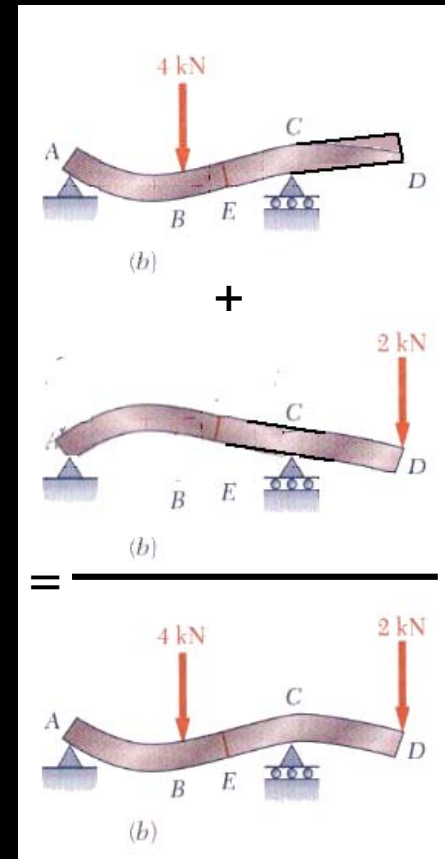

# Steel Beams

- *lateral stability - bracing*
- *local buckling – stiffen, or bigger  $I_y$*

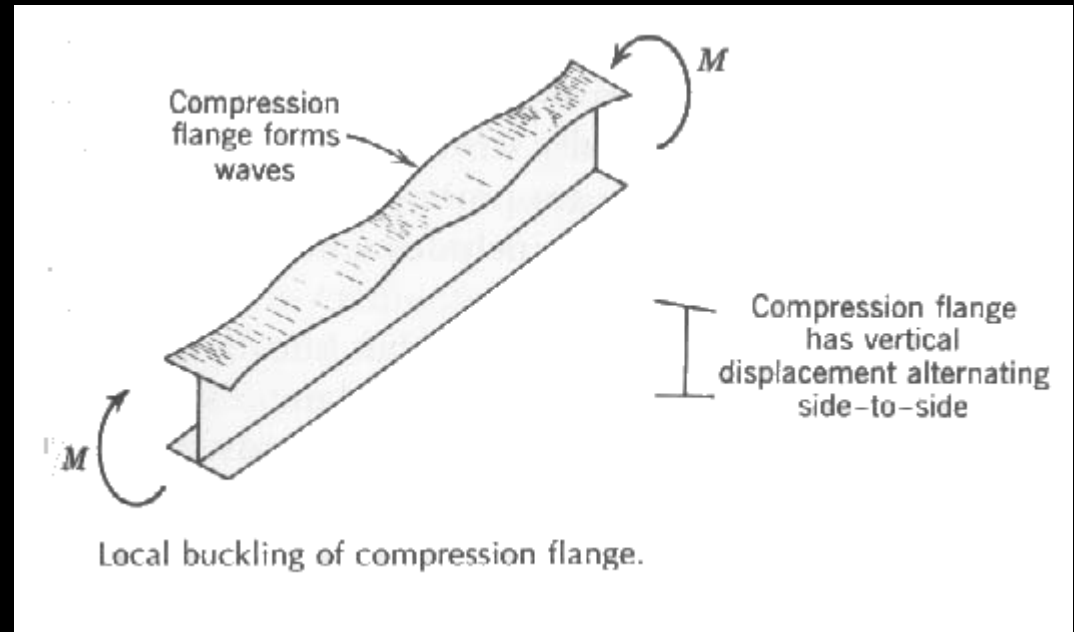
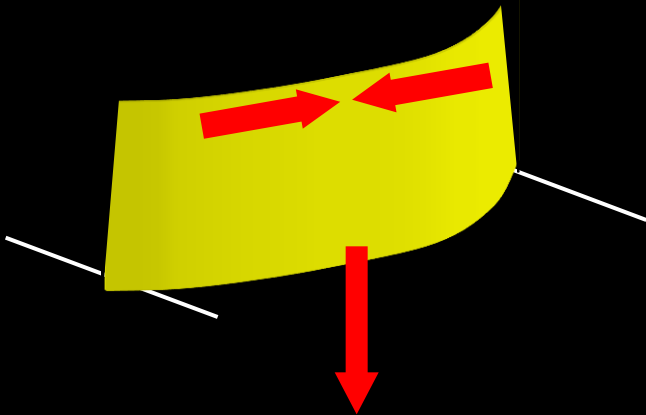



# Local Buckling

- *steel I beams*
- *flange*
  - *buckle in direction of smaller radius of gyration*
- *web*
  - *force*
  - *“crippling”*

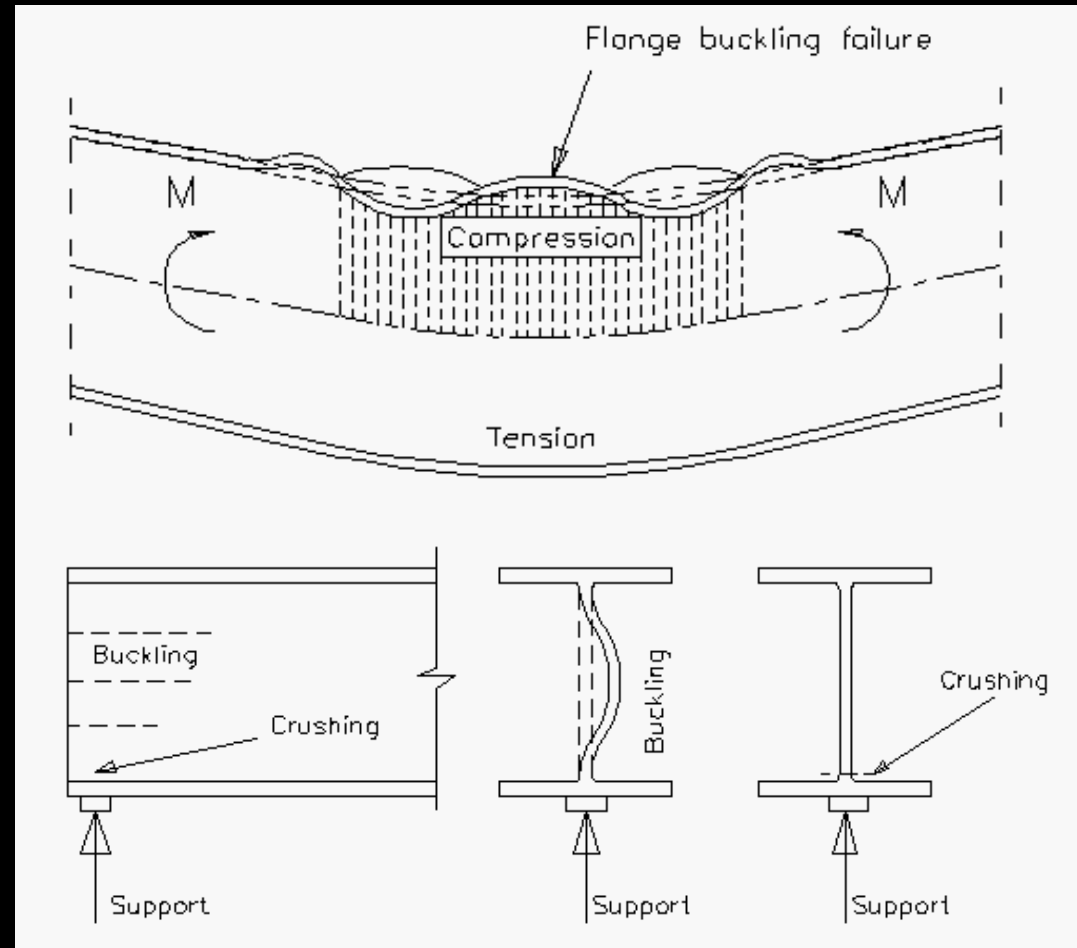

# Local Buckling

- flange

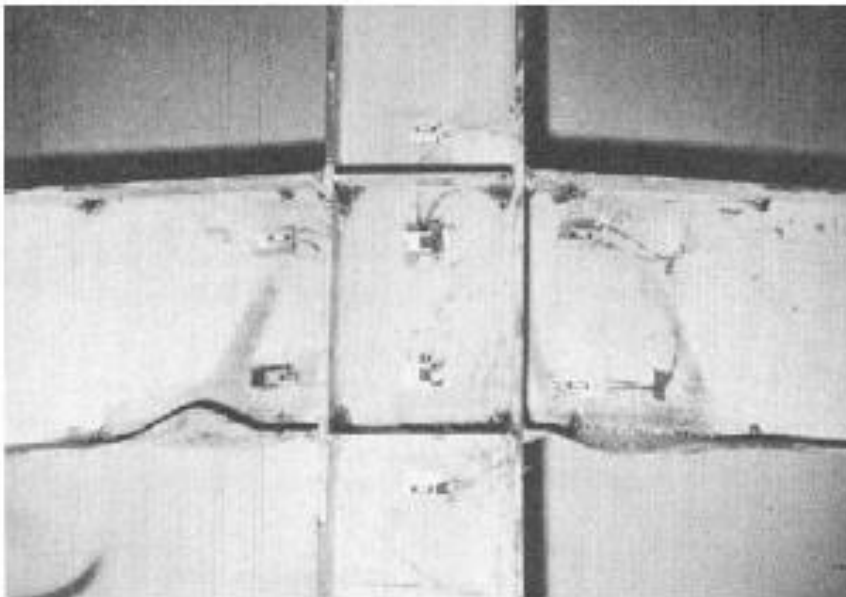

Figure 2-5. Flange Local Bending Limit State  
(Beedle, L.S., Christopher, R., 1964)

- web



Figure 2-7. Web Local Buckling Limit State  
(SAC Project)

# Shear in Web

- panels in plate girders or webs with large shear
- buckling in compression direction
- add stiffeners

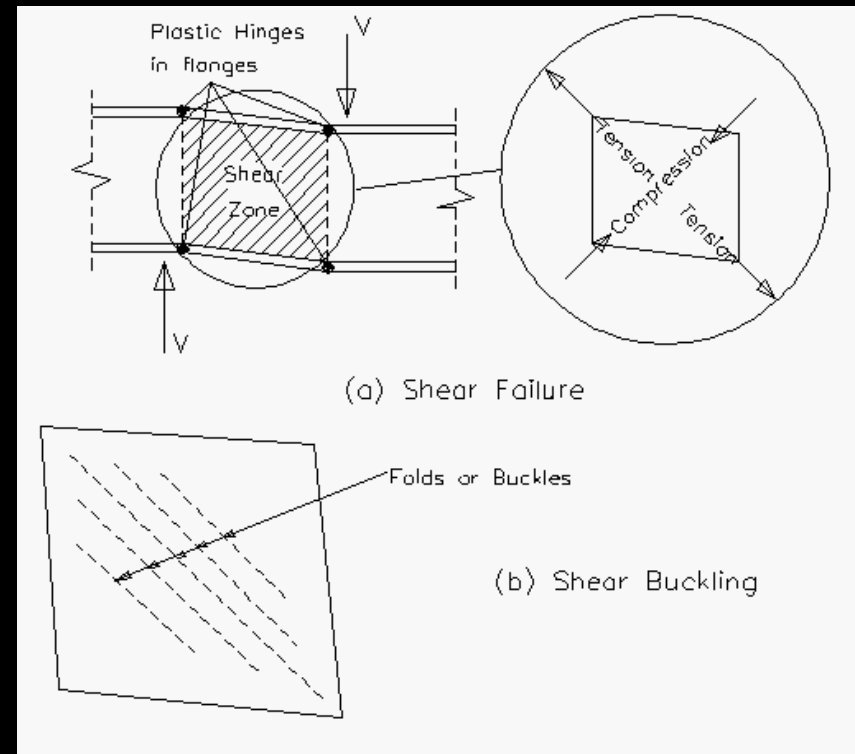
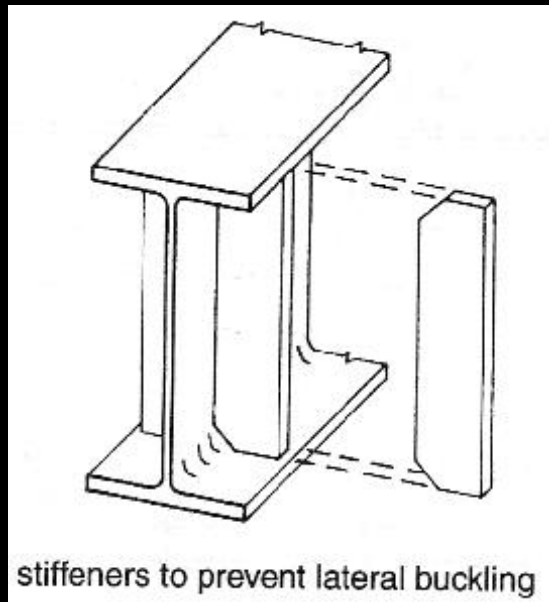

# Shear in Web

- *plate girders and stiffeners*



# Steel Beams

- *bearing*
  - provide adequate area
  - prevent local yield of flange and web

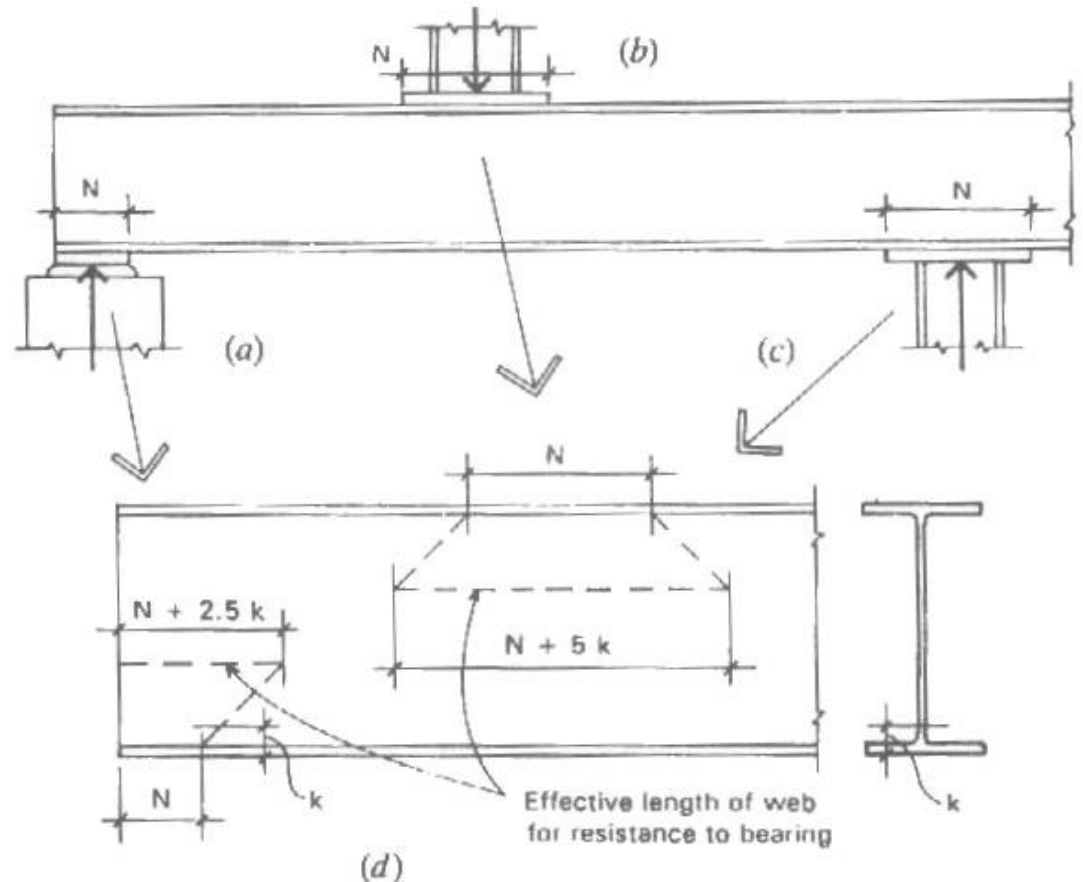

**Figure 9.10** Considerations for bearing in beams with thin webs, as related to web crippling (buckling of the thin web in compression).

# LRFD - Flexure

---

$$\sum \gamma_i R_i = M_u \leq \phi_b M_n = 0.9 F_y Z$$

$M_u$  - maximum moment

$\phi_b$  - resistance factor for bending = 0.9

$M_n$  - nominal moment (ultimate capacity)

$F_y$  - yield strength of the steel

$Z$  - plastic section modulus\*

# Internal Moments - at yield

- material hasn't failed

$$M_y = \frac{I}{c} f_y = \frac{bh^2}{6} f_y$$

$$= \frac{b(2c)^2}{6} f_y = \frac{2bc^2}{3} f_y$$

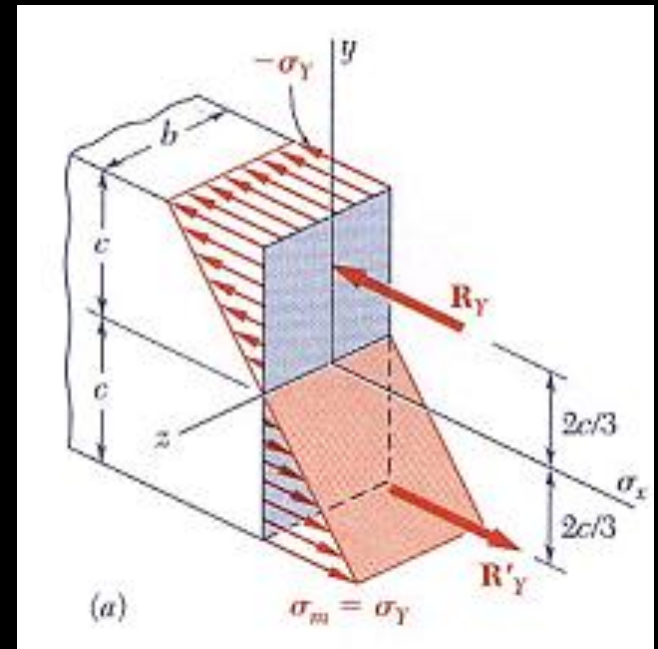

# Internal Moments - ALL at yield

- all parts reach yield
- plastic hinge forms
- ultimate moment
- $A_{tension} = A_{compression}$

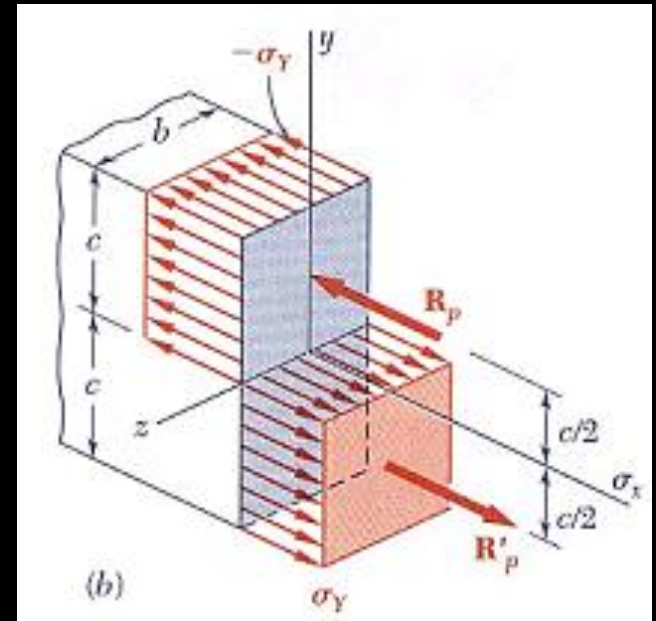

$$M_p = bc^2 f_y = \frac{3}{2} M_y$$

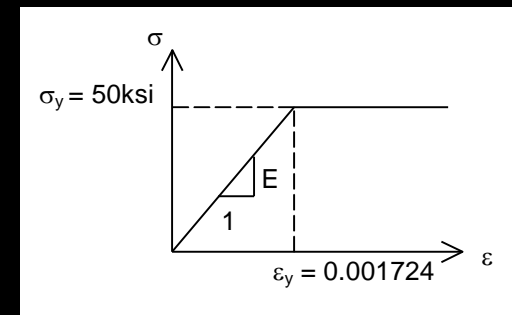



# *n.a. of Section at Plastic Hinge*

- *cannot guarantee at centroid*
- $f_y \cdot A_1 = f_y \cdot A_2$
- *moment found from yield stress times moment area*

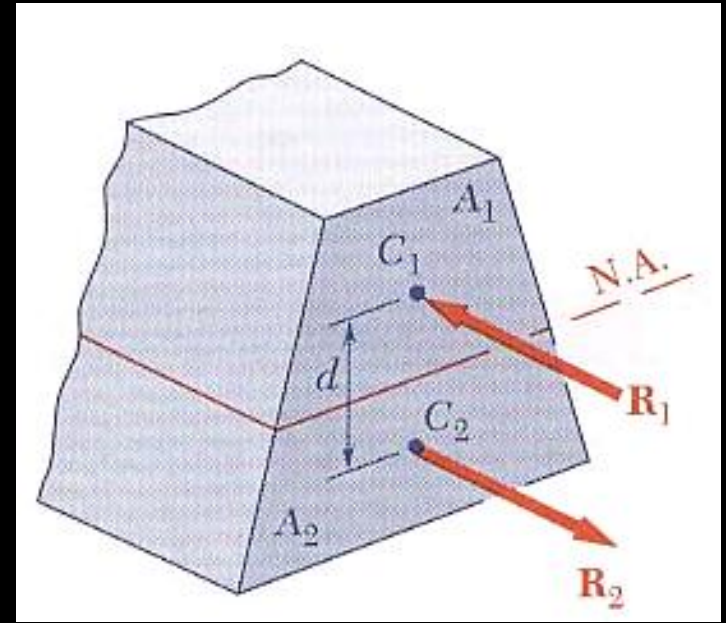

$$M_p = f_y A_1 d = f_y \sum_{n.a} A_i d_i$$

# Plastic Hinge Development

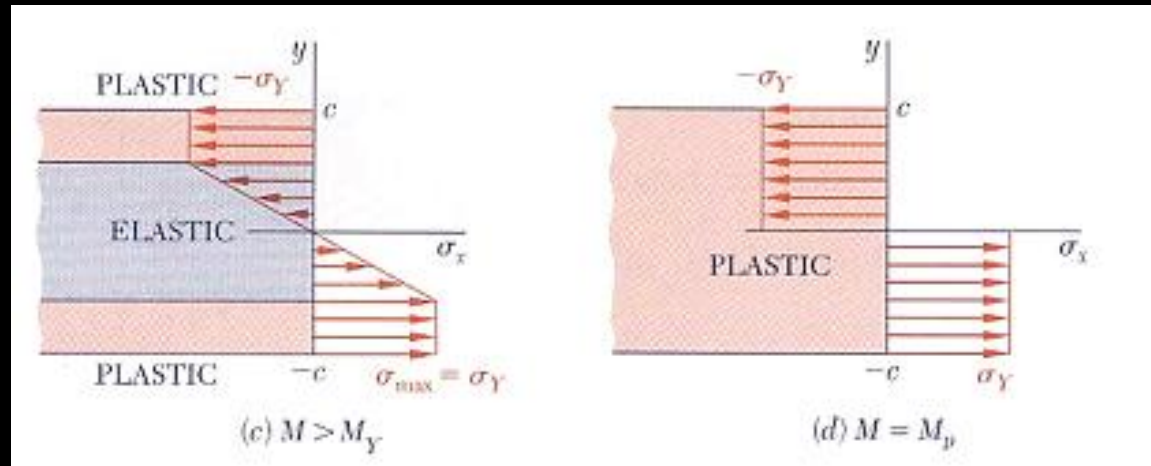
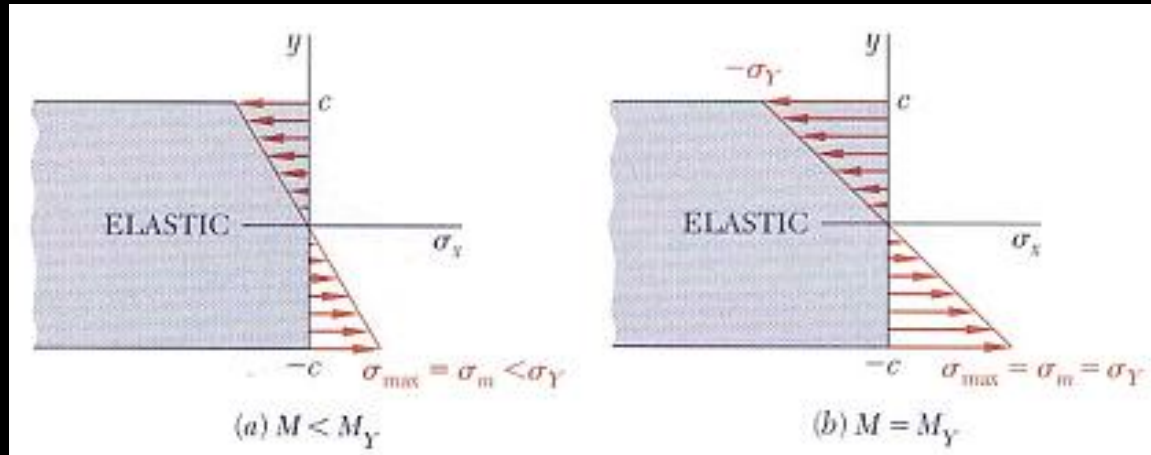

# Plastic Hinge Examples

- *stability can be effected*

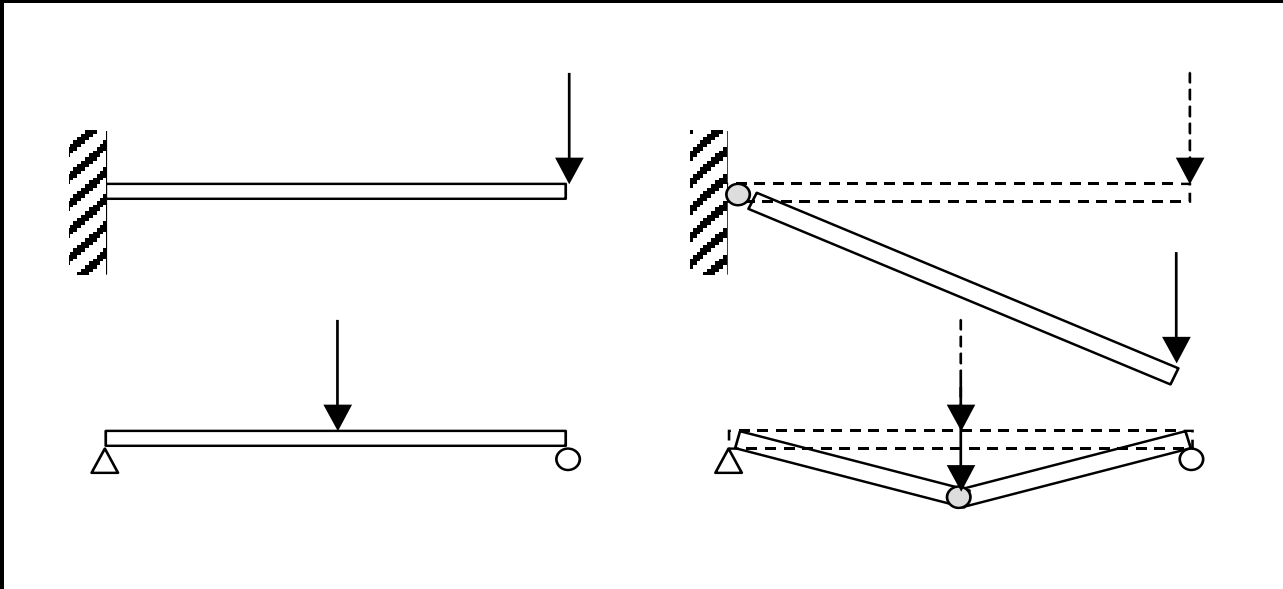

# Plastic Section Modulus

---

- *shape factor,  $k$*

*= 3/2 for a rectangle*

*≈ 1.1 for an I*



$$k = \frac{M_p}{M_y}$$

$$k = \frac{Z}{S}$$

- *plastic modulus,  $Z$*

$$Z = \frac{M_p}{f_y}$$

# *LRFD – Shear (compact shapes)*

---

$$\Sigma \gamma_i R_i = V_u \leq \phi_v V_n = 1.0 ( 0.6 F_{yw} A_w )$$

$V_u$  - maximum shear

$\phi_v$  - resistance factor for shear = 1.0

$V_n$  - nominal shear

$F_{yw}$  - yield strength of the steel in the web

$A_w$  - area of the web =  $t_w d$

# LRFD - Flexure Design

---

- *limit states for beam failure*

1. *yielding*

$$L_p = 1.76 r_y \sqrt{\frac{F_y}{E}}$$

2. *lateral-torsional buckling\**

3. *flange local buckling*

4. *web local buckling*

- *minimum  $M_n$  governs*

$$\sum \gamma_i R_i = M_u \leq \phi_b M_n$$

# Compact Sections

- plastic moment can form before any buckling
- criteria

$$-\frac{b_f}{2t_f} \leq 0.38 \sqrt{\frac{E}{F_y}}$$

$$-\text{and } \frac{h_c}{t_w} \leq 3.76 \sqrt{\frac{E}{F_y}}$$

TABLE A.3 Properties of W Shapes

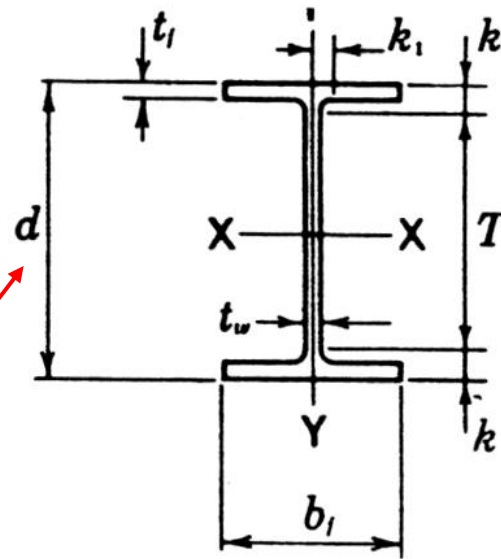

# Lateral Torsional Buckling

$$M_n = C_b \left[ \begin{array}{l} \text{moment based on} \\ \text{lateral buckling} \end{array} \right] \leq M_p$$

$$C_b = \frac{12.5M_{max}}{2.5M_{max} + 2M_A + 4M_B + 3M_C}$$

$C_b$  = modification factor

$M_{max}$  - |max moment|, unbraced segment

$M_A$  - |moment|, 1/4 point

$M_B$  = |moment|, center point

$M_C$  = |moment|, 3/4 point

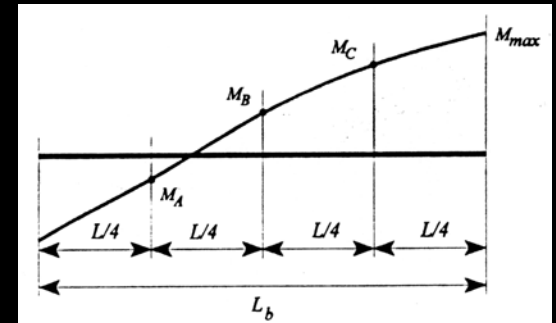



# Beam Design Charts

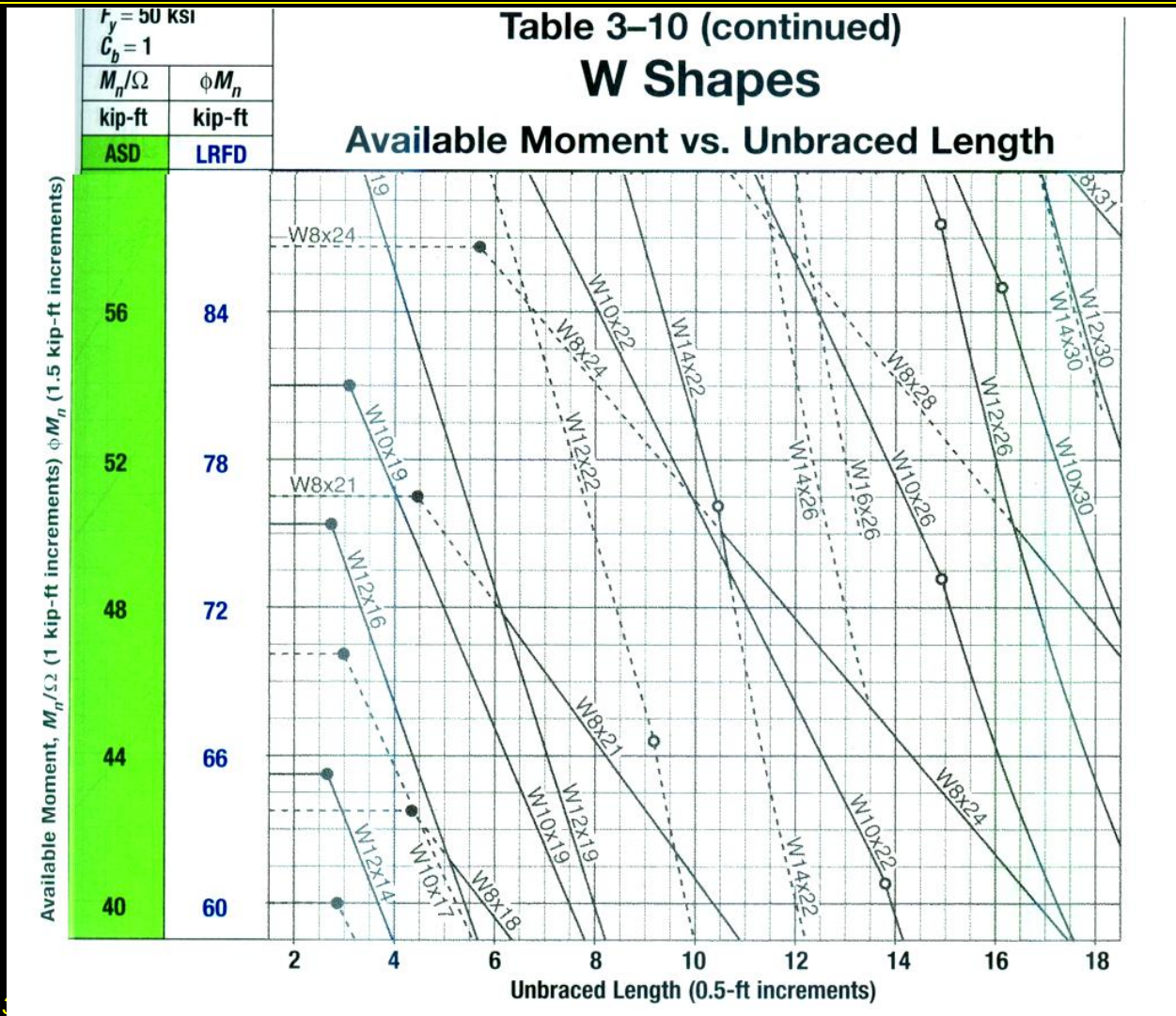

# Charts & Deflections

---

- *beam charts*
  - *solid line is most economical*
  - *dashed indicates there is another more economical section*
  - *self weight is NOT included in  $M_n$*
- *deflections*
  - *no factors* *are applied to the loads*
  - *often governs the design*

# *Design Procedure (revisited)*

---

- 1. Know unbraced length, material, design method ( $\Omega$ ,  $\phi$ )*
- 2. Draw  $V$  &  $M$ , finding  $M_{max}$*
- 3. Calculate  $Z_{req'd}$  ( $M_a \leq M_n/\Omega$ )  
( $M_u \leq \phi_b M_n$ )*
- 4. Choose (economical) section from section or beam capacity charts*

# Beam Charts by $S_x$ (Appendix A)

Table 11 Listing of W Shapes in Descending Order of  $S_x$  for Beam Design.

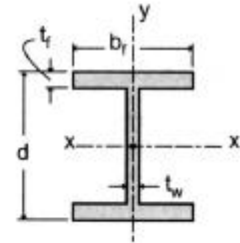

$S_x$		Allowable Stress Design—Selected Beam Shapes				$S_x$
$S_x$ —US (in. <sup>3</sup> )	Section	$S_x$ —SI (10 <sup>3</sup> × mm <sup>3</sup> )	$S_x$ —US (in. <sup>3</sup> )	Section	$S_x$ —SI (10 <sup>3</sup> × mm <sup>3</sup> )	
448	W33 × 141	7350	188	W18 × 97	3080	
439	W36 × 135	7200				
411	W27 × 146	6740	176	W24 × 76	2890	
			175	W16 × 100	2870	
406	W33 × 130	6660	173	W14 × 109	2840	
380	W30 × 132	6230	171	W21 × 83	2800	
371	W24 × 146	6080	166	W18 × 86	2720	
			157	W14 × 99	2570	
359	W33 × 118	5890	155	W16 × 89	2540	
355	W30 × 124	5820				
			154	W24 × 68	2530	
329	W30 × 116	5400	151	W21 × 73	2480	
329	W24 × 131	5400	146	W18 × 76	2390	
329	W21 × 147	5400	143	W14 × 90	2350	

# Beam Charts by $Z_x$

**TABLE 9.1 Load Factor Resistance Design Selection for Shapes Used as Beams**

Designation	$Z_x$ in. <sup>3</sup>	$F_y = 36$ ksi				$F_y = 50$ ksi				$r_y$ in.	$b_f/2t_f$	$h/t_w$	$X_1$ ksi	$X_2 \times 10^6$ (1/ksi) <sup>2</sup>
		$L_p$ ft	$L_r$ ft	$M_p$ kip-ft	$M_r$ kip-ft	$L_p$ ft	$L_r$ ft	$M_p$ kip-ft	$M_r$ kip-ft					
<b>W 33 × 141</b>	<b>514</b>	<b>10.1</b>	<b>30.1</b>	<b>1,542</b>	<b>971</b>	<b>8.59</b>	<b>23.1</b>	<b>2,142</b>	<b>1,493</b>	<b>2.43</b>	<b>6.01</b>	<b>49.6</b>	<b>1,800</b>	<b>17,800</b>
W 30 × 148	500	9.50	30.6	1,500	945	8.06	22.8	2,083	1,453	2.28	4.44	41.6	2,310	6,270
W 24 × 162	468	12.7	45.2	1,404	897	10.8	32.4	1,950	1,380	3.05	5.31	30.6	2,870	2,260
W 24 × 146	418	12.5	42.0	1,254	804	10.6	30.6	1,742	1,237	3.01	5.92	33.2	2,590	3,420
<b>W 33 × 118</b>	<b>415</b>	<b>9.67</b>	<b>27.8</b>	<b>1,245</b>	<b>778</b>	<b>8.20</b>	<b>21.7</b>	<b>1,729</b>	<b>1,197</b>	<b>2.32</b>	<b>7.76</b>	<b>54.5</b>	<b>1,510</b>	<b>37,700</b>
W 30 × 124	408	9.29	28.2	1,224	769	7.88	21.5	1,700	1,183	2.23	5.65	46.2	1,930	13,500
W 21 × 147	373	12.3	46.4	1,119	713	10.4	32.8	1,554	1,097	2.95	5.44	26.1	3,140	1,590
W 24 × 131	370	12.4	39.3	1,110	713	10.5	29.1	1,542	1,097	2.97	6.70	35.6	2,330	5,290
W 18 × 158	356	11.4	56.5	1,068	672	9.69	38.0	1,483	1,033	2.74	3.92	19.8	4,410	403
<b>W 30 × 108</b>	<b>346</b>	<b>8.96</b>	<b>26.3</b>	<b>1,038</b>	<b>648</b>	<b>7.60</b>	<b>20.3</b>	<b>1,442</b>	<b>997</b>	<b>2.15</b>	<b>6.89</b>	<b>49.6</b>	<b>1,680</b>	<b>24,200</b>
W 27 × 114	343	9.08	28.2	1,029	648	7.71	21.3	1,429	997	2.18	5.41	42.5	2,100	9,220
W 24 × 117	327	12.3	37.1	981	631	10.4	27.9	1,363	970	2.94	7.53	39.2	2,090	8,190
W 21 × 122	307	12.2	41.0	921	592	10.3	29.8	1,279	910	2.92	6.45	31.3	2,630	3,160
W 18 × 130	290	11.3	47.7	870	555	9.55	32.8	1,208	853	2.7	4.65	23.9	3,680	810
<b>W 30 × 90</b>	<b>283</b>	<b>8.71</b>	<b>24.8</b>	<b>849</b>	<b>531</b>	<b>7.39</b>	<b>19.4</b>	<b>1,179</b>	<b>817</b>	<b>2.09</b>	<b>8.52</b>	<b>57.5</b>	<b>1,410</b>	<b>49,600</b>
W 24 × 103	280	8.29	27.0	840	531	7.04	20.0	1,167	817	1.99	4.59	39.2	2,390	5,310
W 27 × 94	278	8.83	25.9	834	527	7.50	19.9	1,158	810	2.12	6.70	49.5	1,740	19,900
W 14 × 145	260	16.6	81.6	780	503	14.1	54.7	1,083	773	3.98	7.11	16.8	4,400	348
W 24 × 94	254	8.25	25.9	762	481	7.00	19.4	1,058	740	1.98	5.18	41.9	2,180	7,800

# Beam Design (revisited)

## 4\*. Include self weight for $M_{max}$

- it's dead load
- and repeat 3 & 4 if necessary

## 5. Consider lateral stability

*Unbraced roof trusses were blown down in 1999 at this project in Moscow, Idaho.*

*Photo: Ken Carper*

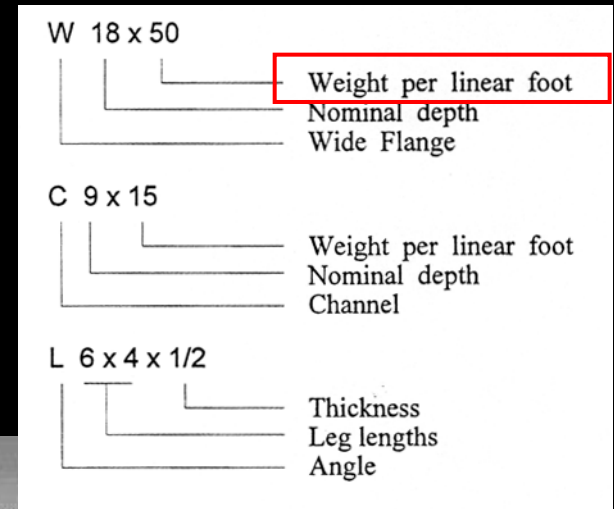

# Beam Design (revisited)

---

## 6. Evaluate shear stresses - horizontal

- $(V_a \leq V_n / \Omega)$  or  $(V_u \leq \phi_v V_n)$

- rectangles and W's  $f_{v-\max} = \frac{3V}{2A} \approx \frac{V}{A_{web}}$

$$V_n = 0.6 F_{yw} A_w$$

- general  $f_{v-\max} = \frac{VQ}{Ib}$

# Beam Design (revisited)

7. Provide adequate bearing area at supports

$$(P_a \leq P_n / \Omega)$$

$$(P_u \leq \phi P_n)$$

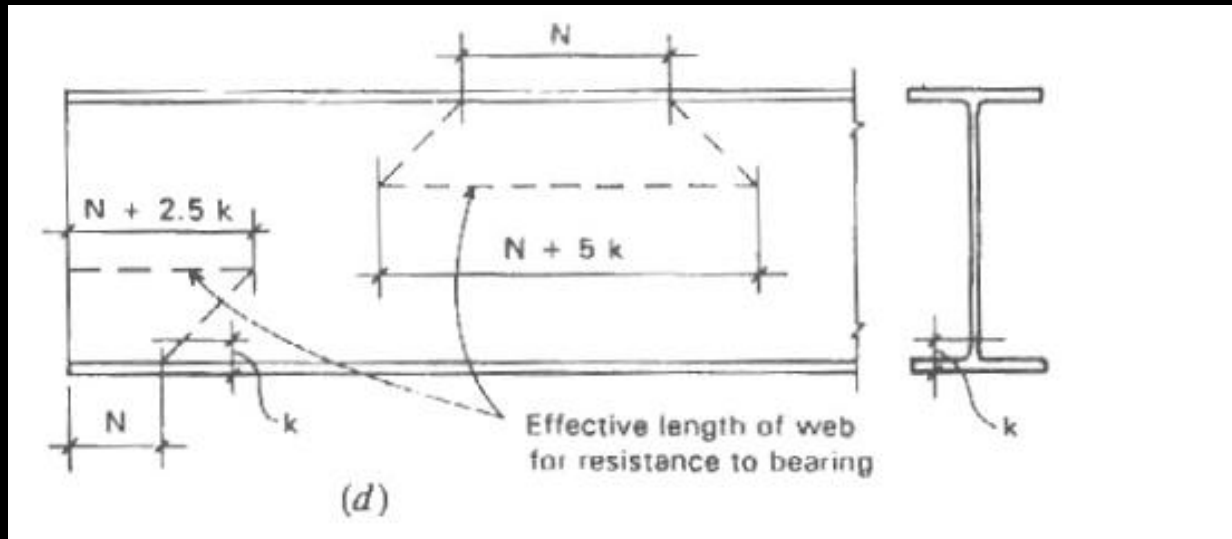



# Beam Design (revisited)

## 8. Evaluate torsion

$$(f_v \leq F_v)$$

- circular cross section

$$f_v = \frac{T\rho}{J}$$

- rectangular

$$f_v = \frac{T}{c_1 ab^2}$$

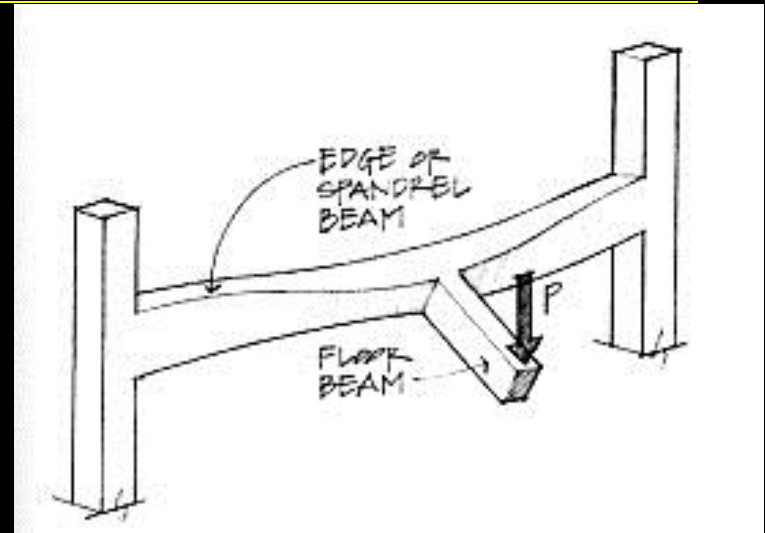
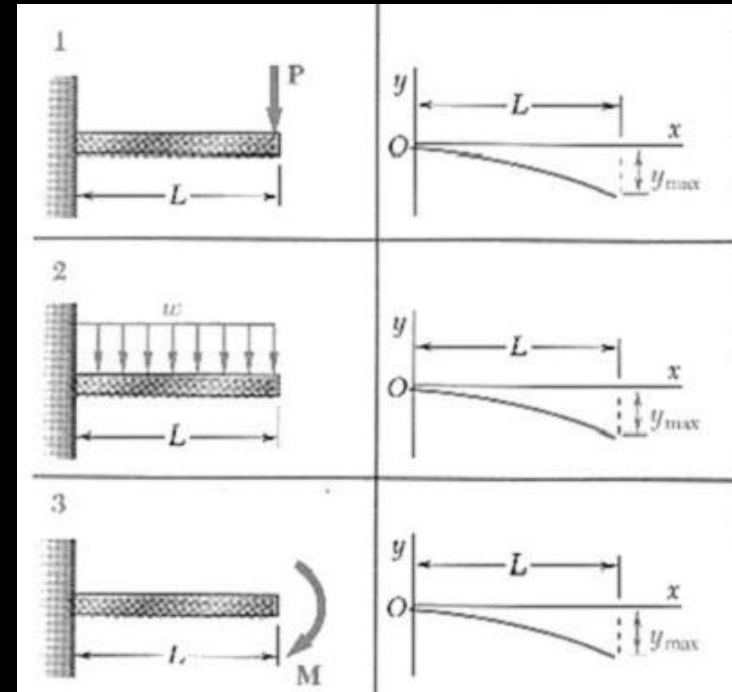
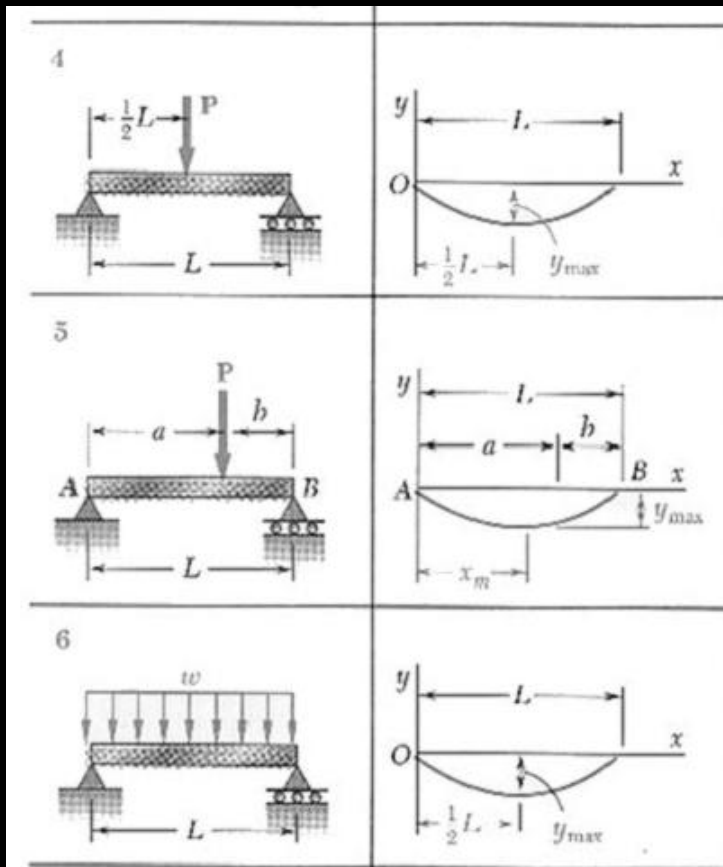

**TABLE 3.1.** Coefficients for Rectangular Bars in Torsion

$a/b$	$c_1$	$c_2$
1.0	0.208	0.1406
1.2	0.219	0.1661
1.5	0.231	0.1958
2.0	0.246	0.229
2.5	0.258	0.249
3.0	0.267	0.263
4.0	0.282	0.281
5.0	0.291	0.291
10.0	0.312	0.312
$\infty$	0.333	0.333

# Beam Design (revisited)

## 9. Evaluate deflections – NO LOAD FACTORS



$$y_{max}(x) = \Delta_{actual} \leq \Delta_{allowable}$$

# Load Tables & Equivalent Load

- uniformly distributed loads
- equivalent “w”

$$M_{\max} = \frac{w_{\text{equivalent}} L^2}{8}$$

8

**LRFD**

**STANDARD LOAD TABLE FOR OPEN WEB STEEL JOISTS, K-SERIES**  
Based on a 50 ksi Maximum Yield Strength - Loads Shown in Pounds per Linear Foot (plf)

Joist Designation	8K1	10K1	12K1	12K3	12K5	14K1	14K3	14K4	14K6	16K2	16K3	16K4	16K5	16K6	16K7	16K9
Depth (in.)	8	10	12	12	12	14	14	14	14	16	16	16	16	16	16	16
Approx. Wt (lbs./ft.)	5.1	5.0	5.0	5.7	7.1	5.2	6.0	6.7	7.7	5.5	6.3	7.0	7.5	8.1	8.6	10.0
Span (ft.)																
8	825 550															
9	825 550															
10	825 480	825 550														
11	798 377	825 542														
12	666 288	825 455	825 550	825 550	825 550											
13	565 225	718 363	825 510	825 510	825 510											
14	486 179	618 289	750 425	825 463	825 463	825 550	825 550	825 550	825 550							
15	421 145	537 234	651 344	814 428	825 434	766 475	825 507	825 507	825 507							
16	369 119	469 192	570 282	714 351	825 396	672 390	825 467	825 467	825 467	825 550	825 550	825 550	825 550	825 550	825 550	825 550
17	415 159	504 234	630 291	825 366	825 324	592 404	742 443	825 443	825 443	768 488	825 526	825 526	825 526	825 526	825 526	825 526
18	369 134	448 197	561 245	760 317	825 272	672 339	825 397	825 408	825 408	825 612	825 682	825 820	825 825	825 825	825 825	825 825
19	331 113	402 167	502 207	681 269	825 230	472 287	592 336	825 383	825 383	612 347	682 386	820 452	825 455	825 455	825 455	825 455
20	298 97	361 142	453 177	613 230	825 197	426 246	534 287	787 347	787 347	552 297	615 330	739 386	825 426	825 426	825 426	825 426
21		327 123	409 153	555 198	825 170	385 212	483 248	582 299	712 299	499 255	556 285	670 333	754 373	822 405	825 406	825 406
22		298 106	373 132	505 172	351 147	439 184	529 215	648 259	648 259	454 222	505 247	609 289	687 323	747 351	825 385	825 385
23			271 93	340 116	462 150	321 128	402 160	483 188	592 226	415 194	462 216	556 252	627 282	682 307	760 339	825 363

load for live load deflection limit  
in RED, total in BLACK

# Sloped Beams

- *stairs & roofs*
- *projected live load*
- *dead load over length*

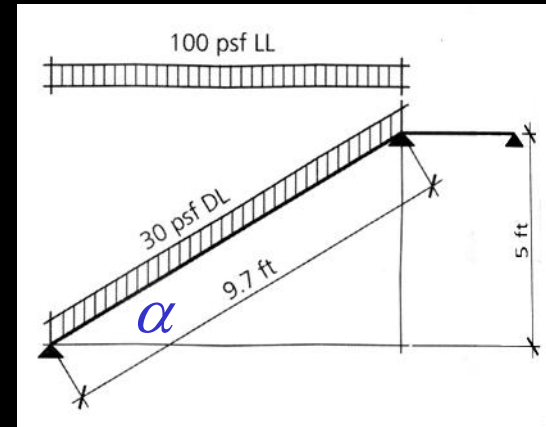

- *perpendicular load to beam:*

$$W_{\perp} = W \cdot \cos \alpha$$

- *equivalent distributed load:*

$$W_{adj.} = \frac{W}{\cos \alpha}$$

# Steel Arches and Frames

- *solid sections*  
*or open web*

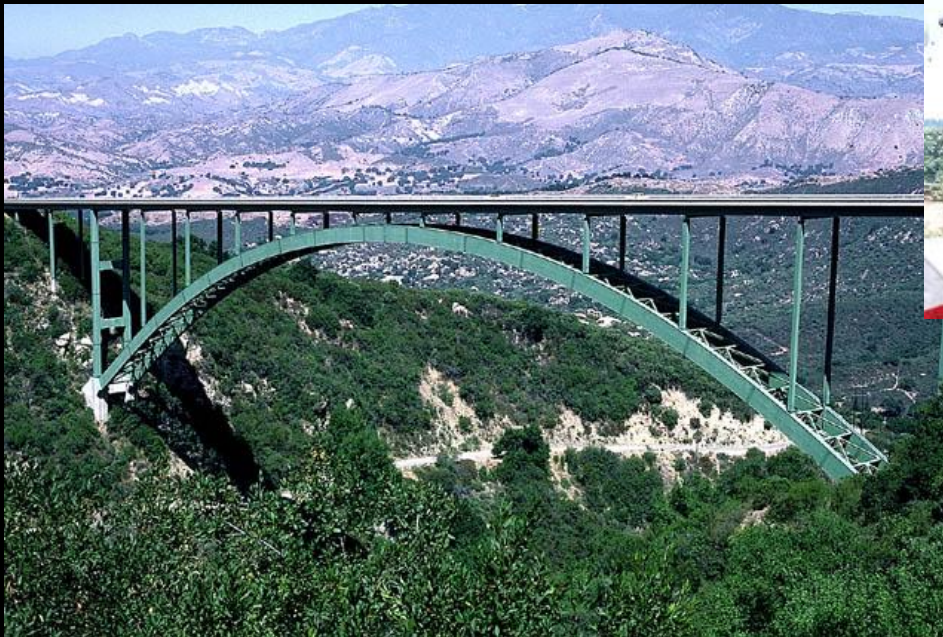

<http://nisee.berkeley.edu/godden>



# Steel Shell and Cable Structures



# Approximate Depths

