

**ARCHITECTURAL STRUCTURES:
FORM, BEHAVIOR, AND DESIGN**

ARCH 331

DR. ANNE NICHOLS

SUMMER 2013

lecture
fourteen



**wood construction:
connections**

Connectors

- *joining*
 - *lapping*
 - *interlocking*
 - *butting*
- *mechanical*
 - “*third-elements*”
- *transfer load at a point, line or surface*
 - *generally more than a point due to stresses*

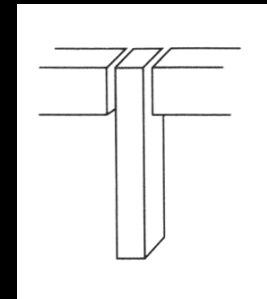
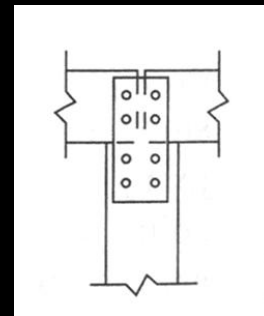
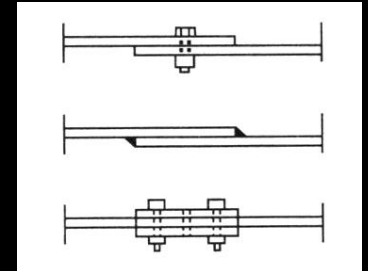
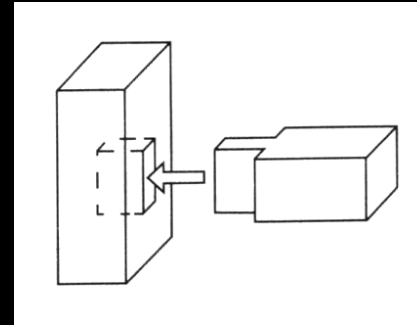

Wood Connectors

- *adhesives*
 - *used in a controlled environment*
 - *can be used with nails*
- *mechanical*
 - *bolts*
 - *lag bolts or lag screws*
 - *nails*
 - *split ring and shear plate connectors*
 - *timber rivets*

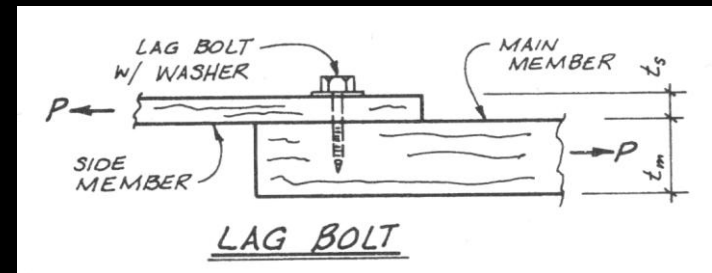
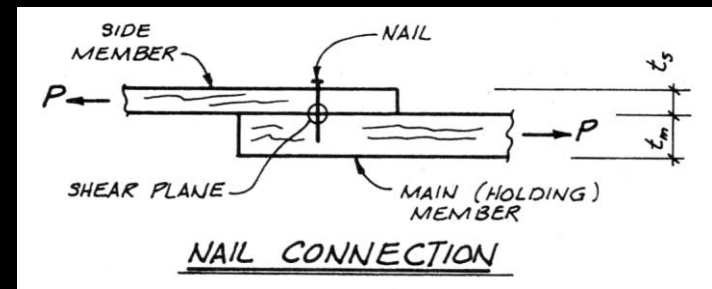

Wood Connections

- *mechanical*

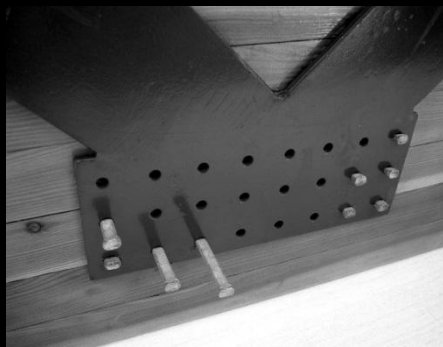
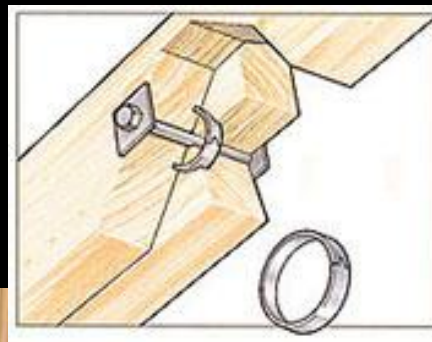
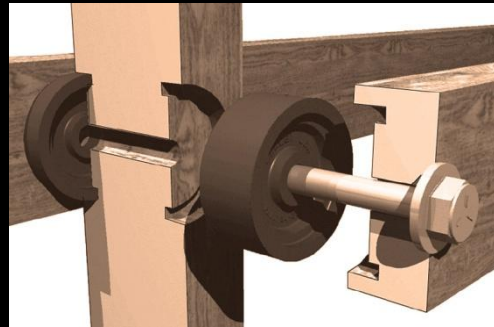

Bolted Joints

- *connected members in tension cause shear stress*

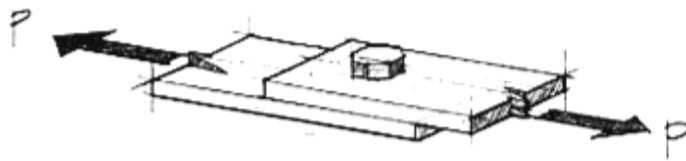

(a) Two steel plates bolted using one bolt.

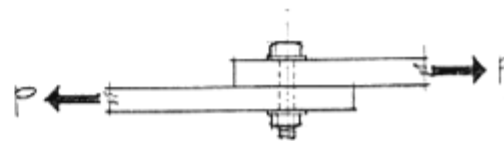

(b) Elevation showing the bolt in

- *connected members in compression cause bearing stress*

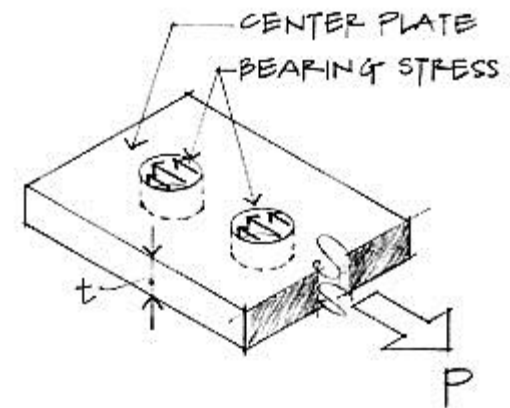

Bearing stress on plate.

Tension Members

- members with holes have reduced area
- increased tension stress
- A_e is effective net area $f_t = \frac{P}{A_e} \left(\text{or } \frac{T}{A_e} \right)$

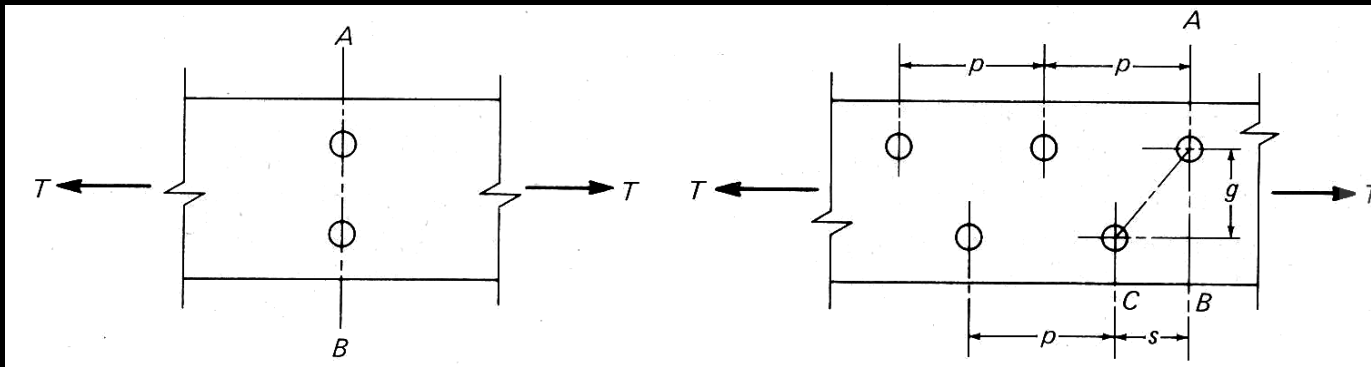

Effective Net Area

- likely path to “rip” across
- bolts divide transferred force too

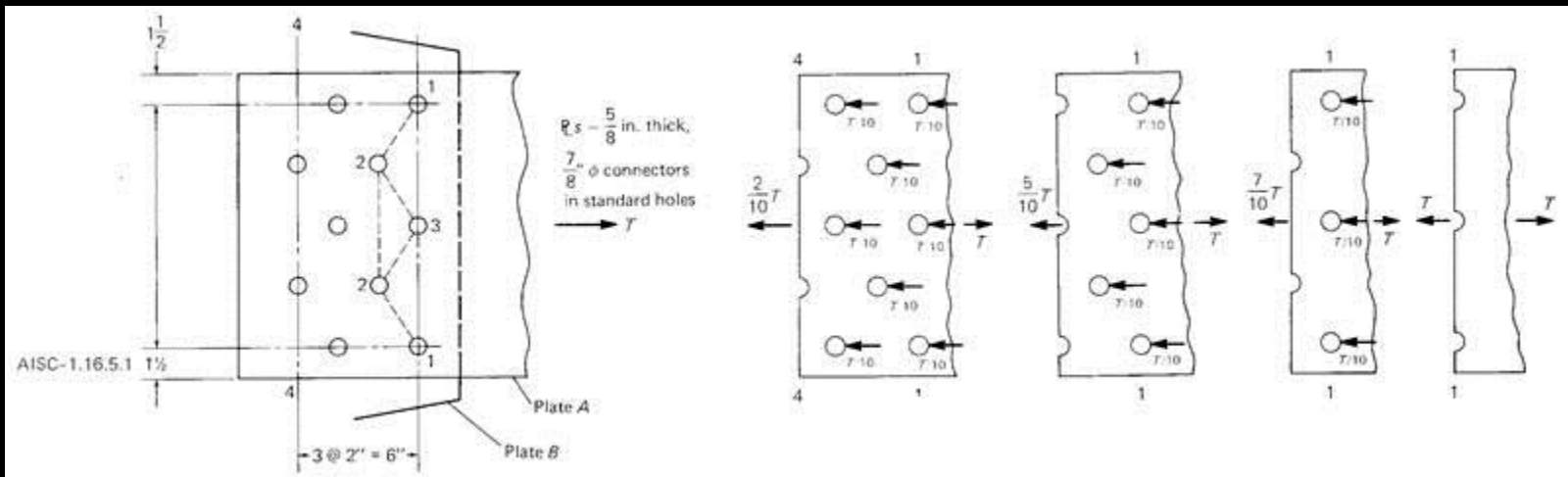

Single Shear

- *seen when 2 members are connected*

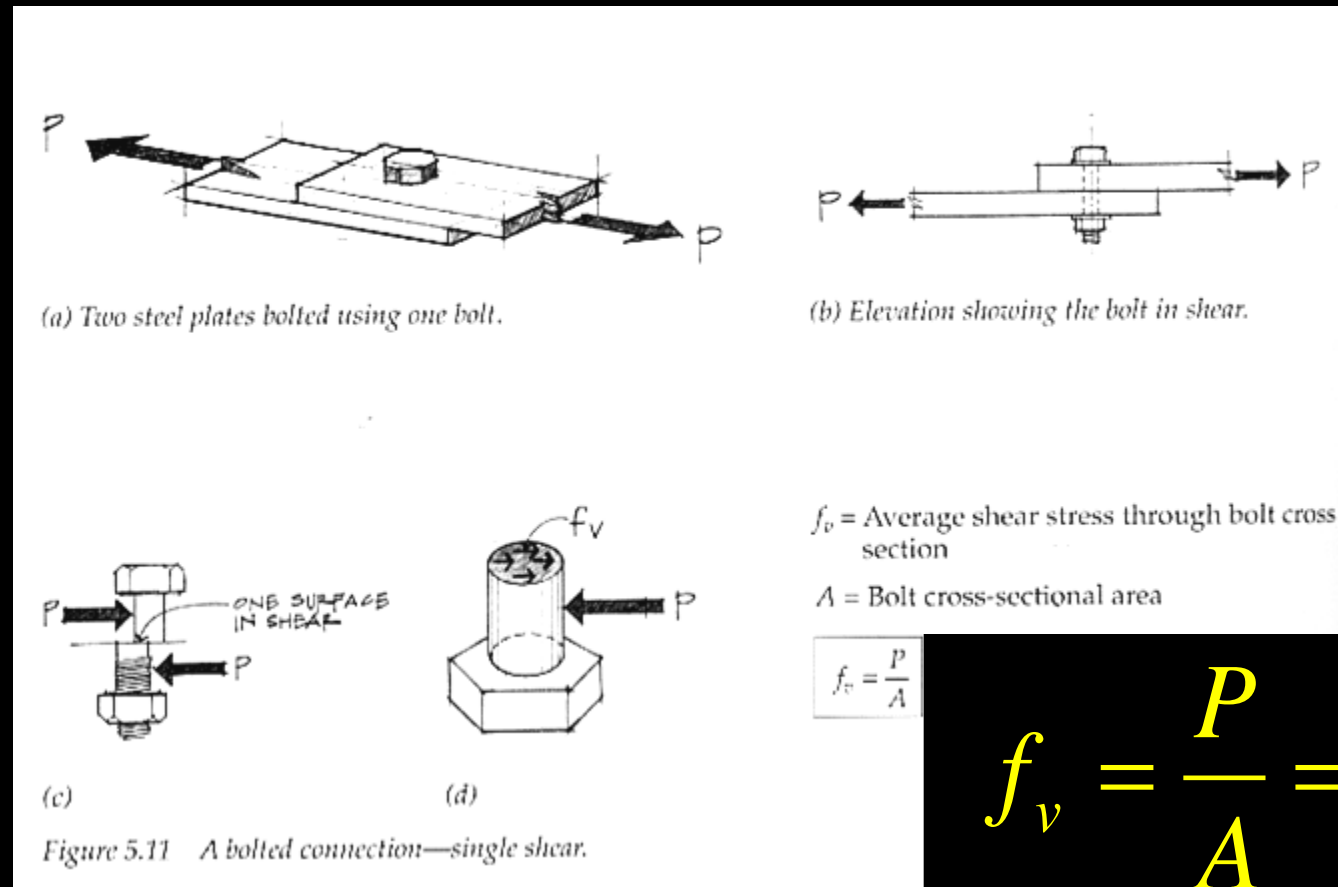

Double Shear

- seen when 3 members are connected

$$\Sigma F = 0 = -P + 2(P/2)$$

$$f_v = \frac{P}{2A}$$

(two shear planes)

$$f_v = \frac{P}{2A} = \frac{P/2}{A} = \frac{P/2}{\pi d^2/4}$$

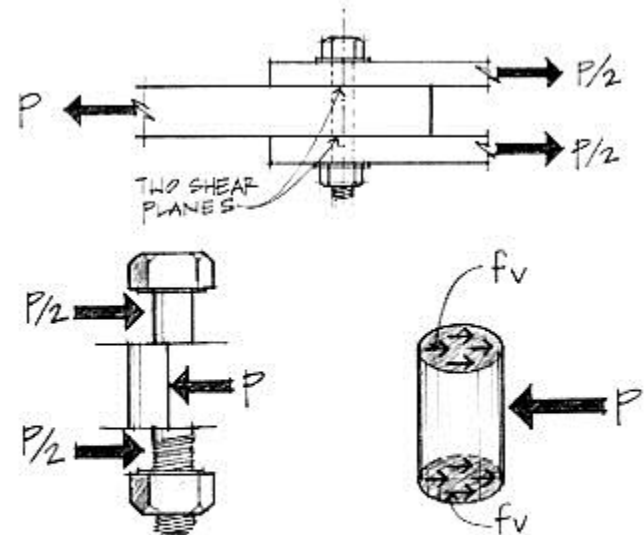

Free-body diagram of middle section of the bolt in shear.

Figure 5.12 A bolted connection in double shear.

Bearing Stress

- *compression & contact*
- *stress limited by species & grain direction to load*
- *projected area*

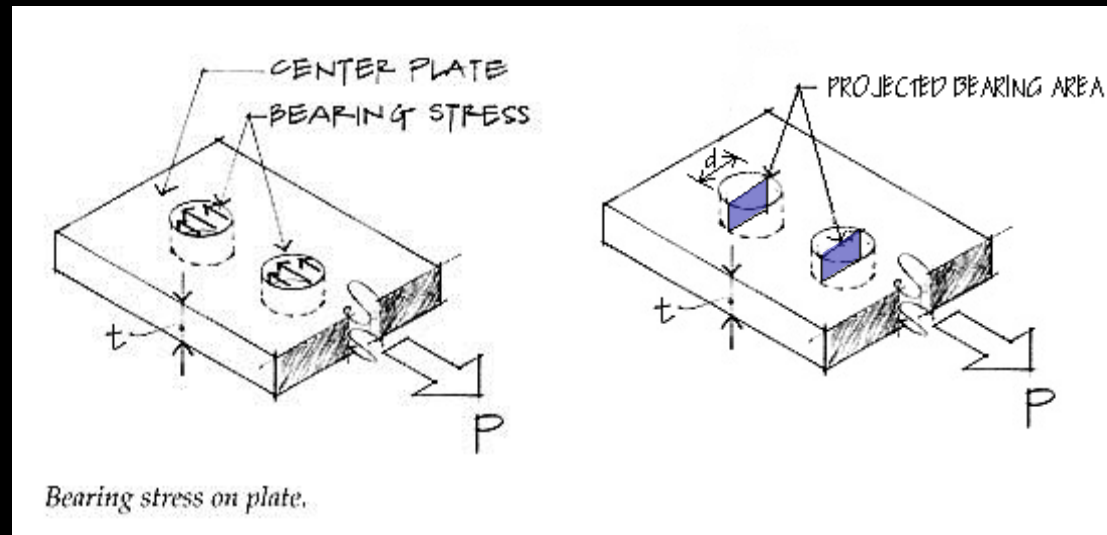

Bearing stress on plate.

$$f_p = \frac{P}{A_{\text{projected}}} = \frac{P}{td}$$

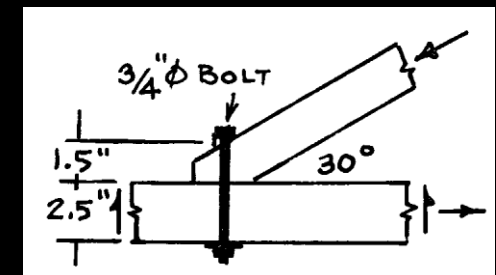

Bolted Joints

- *twisting*

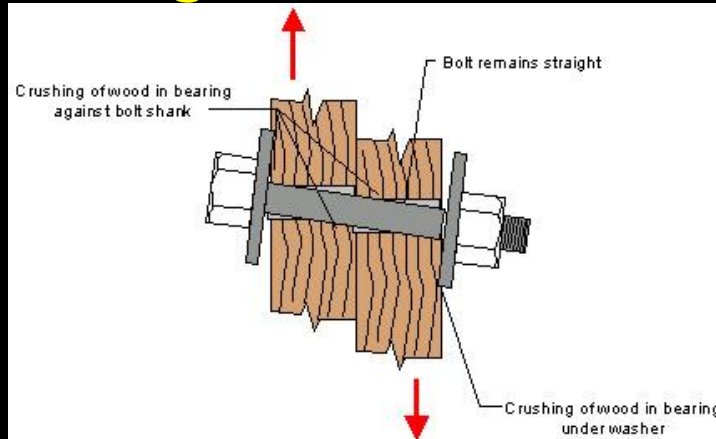

www.timber.org.au

- *tear out*

- *shear strength*

- *end distance & spacing*

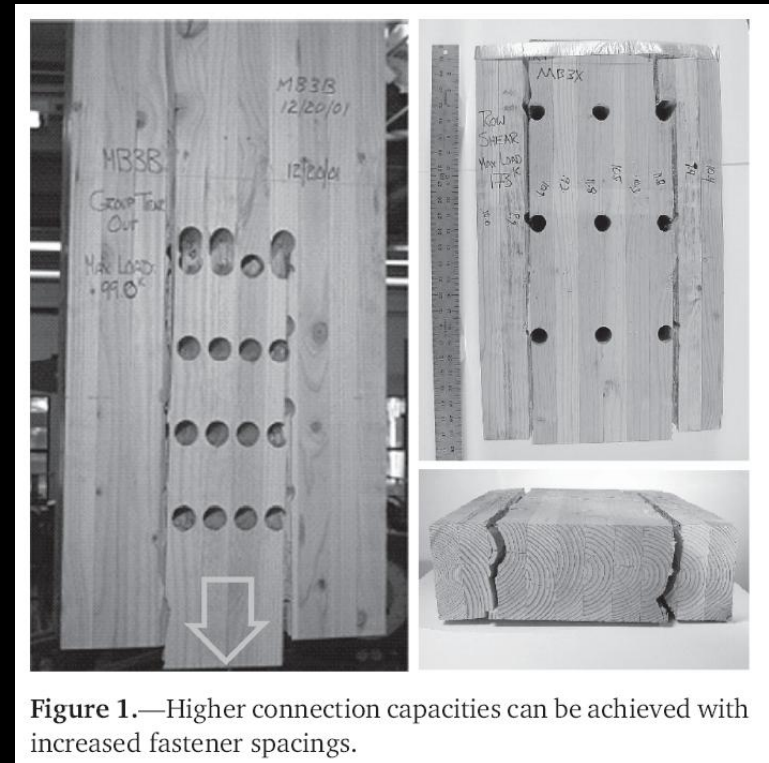
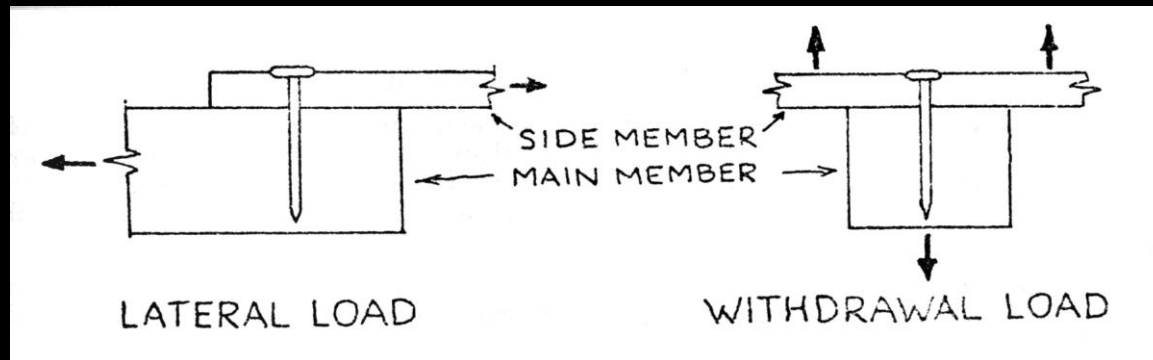

Figure 1.—Higher connection capacities can be achieved with increased fastener spacings.

Taylor & Line 2002

Nailed Joints

- *tension stress (pullout)*
- *shear stress nails presumed to share load by distance from centroid of nail pattern*



Nailed Joints

- sized by pennyweight units / length
- embedment length
- dense wood, more capacity

*NDS

TABLE 7.1 Lateral Load Capacity of Common Wire Nails (lb/nail)

Side Member Thickness, t_s (in.)	Nail Length, L (in.)	Nail Diameter, D (in.)	Pennyweight	Load per Nail for Douglas Fir-Larch $G = 0.50, Z$ (lb)
<i>Structural Plywood Side Members</i>				
$\frac{3}{8}$	2	0.113	6d	48
	2½	0.131	8d	63
	3	0.148	10d	76
$\frac{1}{2}$	2	0.113	6d	50
	2½	0.131	8d	65
	3	0.148	10d	78
	3½	0.162	16d	92

Connectors Resisting Beam Shear

- plates with

- nails
- rivets
- bolts

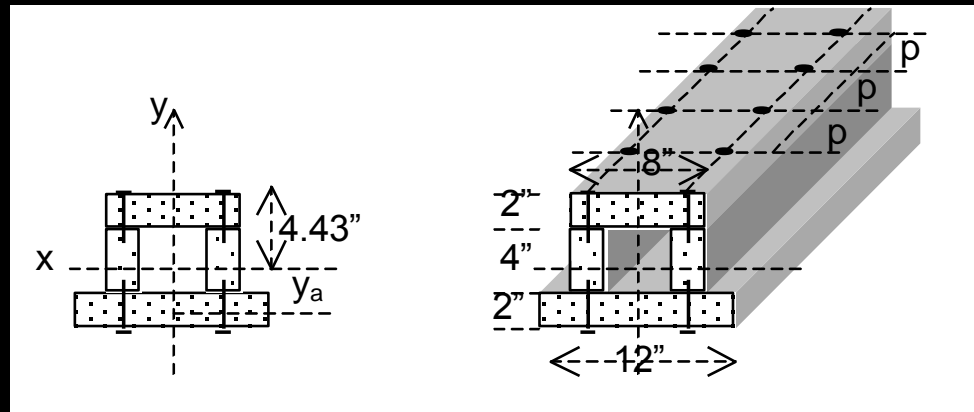

- splices

- V from beam load related to $V_{longitudinal}$

$$\frac{V_{longitudinal}}{p} = \frac{VQ}{I}$$

$$nF_{connector} \geq \frac{VQ_{connected\ area}}{I} \cdot p$$

Vertical Connectors

- isolate an area with vertical interfaces

$$nF_{connector} \geq \frac{VQ_{connected\ area}}{I} \cdot p$$

