

ARCH 331. Assignment #6

Date: 6/18/13, due 6/21/13

Pass-fail work

Problems: supplemental problems (6A, etc.) **and** from Onouye Chapters 4, 5, 9 & 10

*Notes: Problems marked with a * have been altered with respect to the problem stated in the text. Multifram or other methods may be used for V & M diagrams and maximums for the problems of chapter 9 when the method is not specified.. Selected problems not required to be worked will be announced in class.*

- (3%) 6A) A reinforced concrete slab is 6 in. thick. If the density is 150 lb/ft^3 , determine the weight per unit area in lb/ft^2 and in kN/m^2 . (un-dimensioned figure). (*dimensional analysis & conversions*)

Partial answer to check with: 3.59 kN/m^2

- (6%) 6B) The compressive force in a column to each service (unfactored) load are: $D = 465 \text{ kN}$, $L = 290 \text{ kN}$, $L_r = 65 \text{ kN}$, $W = 110 \text{ kN}$, $E = 245 \text{ kN}$. The wind load can also result in a tensile force. Determine the design load for the column based on LRFD using ASCE-7 load combinations (see Note Set 13.6) (*load factors*)

Partial answer to check with: $\max\{651, 1054.5, (952 \text{ or } 717, 607), (990.5 \text{ or } 770.5), 1093, (528.5 \text{ or } 308.5), 663.5\} \text{ kN}$.

- (6%) 6C) Roof beams that weigh 50 lb/ft and are spaced at $10'$ center to center support an additional dead load of 30 lb/ft^2 . Code specified roof loads are 35 lb/ft^2 downward (due to roof live load, snow or rain) and 25 lb/ft^2 upward or downward (due to wind). Determine the critical loading for LRFD using ASCE-7 load combinations (see Note Set 13.6).

(load tracing and load factors)

Partial answer to check with: $\max\{490, 595, (1105 \text{ or } 855), (845 \text{ or } 345), 490, (565 \text{ or } 65), 315\} \text{ lb/ft}$.

- (10%) *4.4.1 A gravity retaining wall as shown is subjected to a lateral soil pressure as a result of an *equivalent fluid density* of 35 pcf . Calculate the resultant horizontal force due to pressure against the wall and the wall's factor of safety against overturning. Assume that concrete has a density of 150 pcf . Check the bearing pressure under the footing. Assume the allowable bearing pressure is 3000 psf . Also check for factor of safety against sliding if the friction coefficient is 0.62 .

(retaining wall behavior)

Partial answer to check with: $SF_{over} = 1.43$, $SF_{slide} = 1.77$, $p_{max} = 2000 \text{ lb/ft}^2$ (under footing)

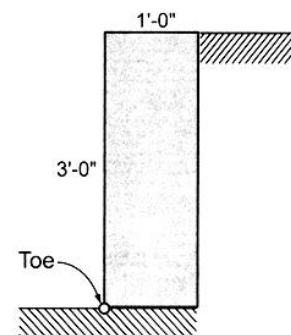

Problem 4.4.1

MORE NEXT PAGE

with load values

(10%) *5.1.4. Draw FBDs and show load conditions for B-1, G-1, and the interior column. **and**

5.1.5. Using the building shown in Problem 5.1.4, draw the FBDs for beam B-2 and girder G-2. Beam B-2 is spaced at 6'-0" o.c. **Find all support reactions.** (load tracing)

Loads:

- Snow = 25 psf
- Roofing and decking = 10 psf
- Truss joists = 3 psf
- Insulation, mech., and elect. = 5 psf
- Beam B-2 = 12 pounds per lineal foot
- Girder G-2 = 40 plf.
- Beams B-1 = 15 lb./ft.
- Girders G-1 = 50 lb./ft.

Partial answer to check with:

- B-1: $w = 335 \text{ lb/ft}$, reaction = 4020 lb
- G-1: 4 loads of 8040 lb and $w (50 \text{ lb/ft})$, reaction = 17.08 k; column: 2 girder and 2 beam reactions = 42.2 k
- B-2: $w = 252 \text{ lb/ft}$, reaction = 2016 lb
- G-2: 4 loads of 2016 and $w = 556 \text{ lb}$, reaction = 12,372 lb (note: the truss joist load is in lb/ft^2 and acts on G-2)

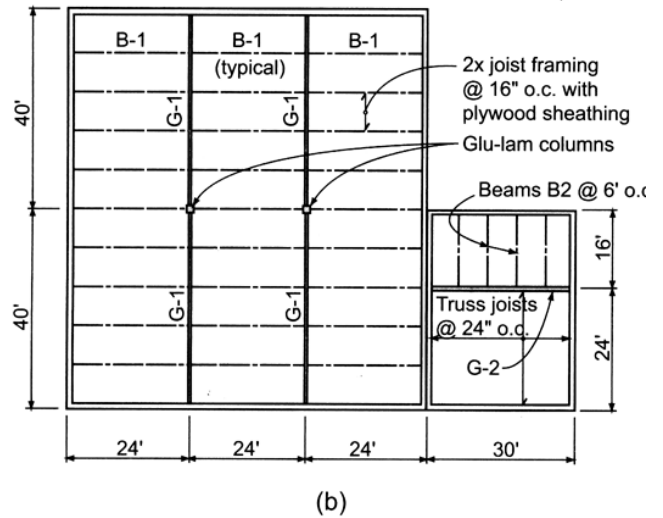

Problem 5.1.4 (a) Warehouse/office building. (b) Roof framing plan. (c) Roof framing—typical section.

(12%) 6D) The floor framing plan is subject to uniform distributed loads of: dead load = 45 psf, live load = 120 psf. Determine the resulting reactions by the beams & load on the columns. (load tracing)

Partial answer to check with: $R_{B2} = 16706.25 \text{ lb}$, $R_{G3@G1} = 10395 \text{ lb}$,
 $R_{G1@C1} = 12529.7 \text{ lb}$, $P_{onC2} = 20,882.8 \text{ lb}$.

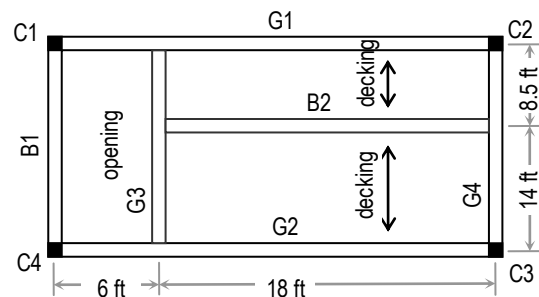
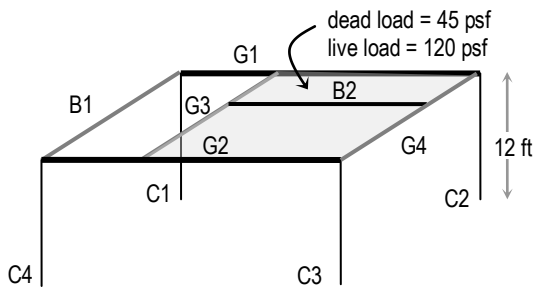

MORE NEXT PAGE

(3%) 6E) For the frame of problem 6D, use Multiframe software to find the column loads to verify your work from load tracing by constructing a 3D model (View 3D). Use the standard steel section you have been assigned which is posted in My Grades on eCampus. Submit the data file (.mdf) on eCampus (under Assignments: Assignment 6) and provide a print of the bending moment (M) and axial force (P) diagrams. Be careful to make joints on all the girders at the location of beam supports. Model the column bases as fixed. **Do not use panels**, but put on linearly distributed loads on **G1, B2 and G2 only**. Model the beam ends with *rotational releases* using the member restraint menu and release (check) the major moment resistance, M_z , for each end.

(10%) *9.1.2 The single overhang beam uses a 4x12 S4S (100 x 300 mm) Douglas fir-larch No. 1 member. Determine the maximum bending stress developed. Is it safely designed? ($F_b = 1300$ psi or 8.97 MPa) most economical member to use assuming a self weight of 10 lb/ft, normal load duration ($C_D = 1$), tabulated stresses of $F_b = 2000$ psi and $F_v = 250$ psi, $E = 1.7 \times 10^6$ psi. Calculated and locate the maximum deflection due *only* to the 400 lb/ft for the member found.

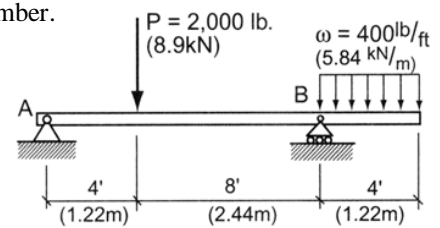

***Use superpositioning with the Beam Diagrams and Formulas to get support reactions and to construct the V & M diagrams.**

(timber strength design and deflection)

Partial answer to check with: $S_{req'd} \geq 26.4 \text{ in.}^3$, $A_{req'd} \geq 9.8 \text{ in.}^2$, and $\Delta > 0.273 \text{ in.}$

(17%) *9.1.22 Design a Douglas fir-larch No. 1 beam to support the load shown. Assume a 7-day live load (construction) duration.

$F_b = 1300$ psi (timber beam design)

$F_v = 85$ psi

$E = 1.6 \times 10^6$ psi

$\Delta_{allow(LL)} = L/360$

* $\gamma = 32 \text{ lb/ft}^3$
 * $\Delta_{allowed (LL+DL)} = L/240$

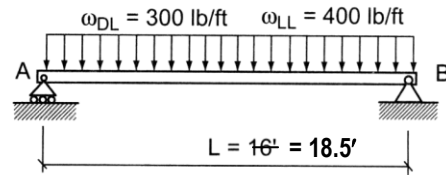

Problem 9.1.22

Partial answers to check with:

$S_{req'd} \geq 221.1 \text{ in.}^3$, $A_{req'd} \geq 91.4 \text{ in.}^2$. First trial self weight $\approx 23 \text{ lb/ft}$. (Expect more trials). Final sections may have $S > 230 \text{ in.}^3$ and $\Delta_{(LL)} \approx 0.3\text{-}0.4 \text{ in.}$, and $\Delta_{(LL+DL)} \approx 0.5\text{-}0.6 \text{ in.}$

(10%) *10.4.3 Determine the axial load capacity of a $6\frac{3}{4}'' \times 10\frac{1}{2}''$ glu-lam column with an area $A = 70.88 \text{ in.}^2$, assuming lateral bracing about the weak axis at the midheight level. Assume pin connections top and bottom in both directions of buckling. ($F_c = 1650 \text{ psi}$; $E = 1.8 \times 10^6 \text{ psi}$) Assume the critical load duration is for one-day live load (wind).
(timber column analysis)

Partial answers to check with:
 $(C_D = 1.33) F'_c = 1080 \text{ psi}, P_a = 76.5 \text{ k}$

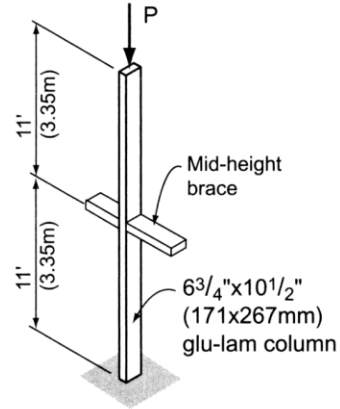

Problem 10.4.3

(10%) *10.4.6 Determine the minimum size ^{6 x} column (Southern pine dense No. 1) required to support an axial load of $P = 25 \text{ kips} = 12.5 \text{ kips}$ assuming an effective column length $L_e = 16 \text{ ft}$. Assume the load duration is normal. For Southern pine dense No. 1, $E = 1.6 \times 10^6 \text{ psi}$, and the tabulated compressive stress parallel to the grain, $F_c = 975 \text{ psi}$.
(timber column design)

no figure

Partial answers to check with: $F'_c = 351 \text{ psi}, A_{req'd} \geq 35.6 \text{ in}^2$ and a section MUST satisfy this requirement

(3%) 6F) Determine the minimum size square column of Douglas Fir Larch, No. 1 grade to support an axial load of 30 k for an effective length of 12 ft under snow load.
(timber column design charts)

Partial answers to check with: possible capacities {3.7 k, 17.6 k, 47.3 k}