

### ARCH 331. Assignment #4

**Date:** 6/11/13, due 6/14/13

*Pass-fail work*

**Problems:** supplemental problems (4A, etc.) **and** from Onouye, Chapters 7, 8 & 9

*Notes: Problems marked with a \* have been altered with respect to the problem stated in the text. Multiframed or other methods may be used for V & M diagrams and maximums for the problems out of chapter 9.*

Selected problems not required to be worked will be announced in class.

- (4%) \*8.2.4 Using the equilibrium method, **write** the equation for the shear,  $V(x)$ , and bending moment,  $M(x)$  with respect to  $x$  that starts at A and extends to B. Verify that the Beam Diagrams and Formulas give the same equations when the values for  $w$  and  $L$  are substituted at point B.  
(*equilibrium method, Beam Diagrams and Formulas*)

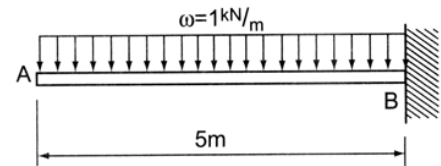

Problem 8.2.4

Partial answers to check with:  $V(5) = -5kN$ ,  
 $M(5) = -12.5 kN\cdot m$

Construct the load, shear, and moment diagrams for the following beam conditions using the semi-graphical method. **\*And indicate maximum design values.**

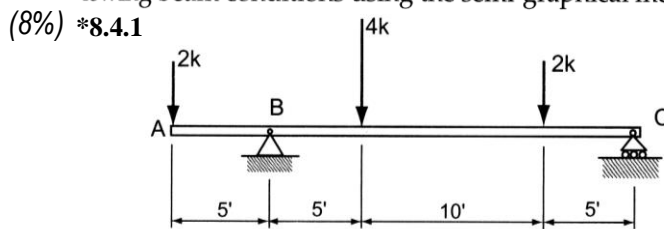

Problem 8.4.1

Partial answers to check with:  
 $V_{max} = +4 k$ ,  $M_{max} = +10 k\cdot ft$

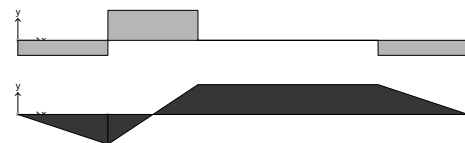

- (8%) \*8.4.3

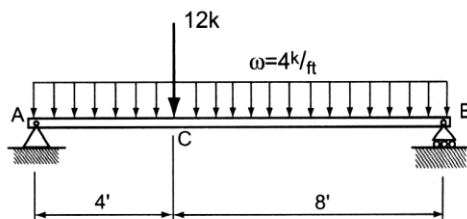

Problem 8.4.3

Partial answers to check with:  
 $V_{max} = +32 k$ ,  $M_{max} = 98 k\cdot ft$

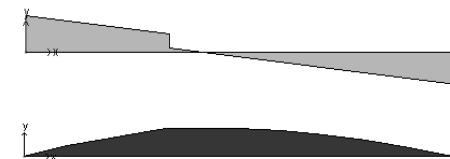

- (8%) \*8.4.4

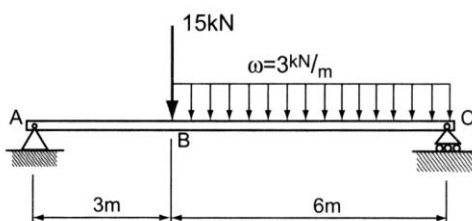

Problem 8.4.4

Partial answers to check with:  
 $V_{max} = -17 kN$ ,  $M_{max} = 48.2 kN\cdot m$

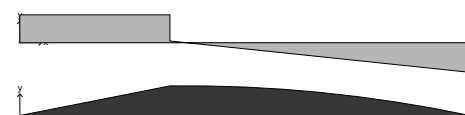

MORE NEXT PAGE

(8%) \*8.4.5

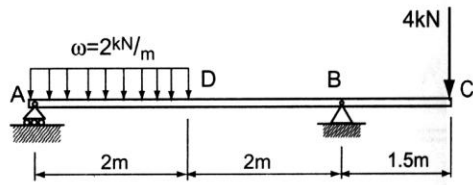

Problem 8.4.5

Partial answers to check with:

$$V_{max} = +4 \text{ kN}, M_{max} = -6 \text{ kN}\cdot\text{m}$$

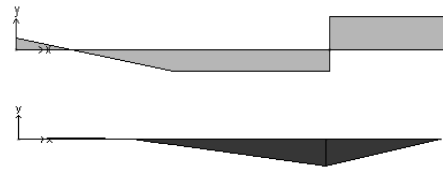

(3%) 4A) For the beam of problem 8.4.5, use Multiframe software to find the shear and bending moment values to verify your work from the semigraphical method. Use the standard steel section you have been assigned which is posted in My Grades on eCampus. Submit the data file (.mfd) on eCampus (under Assignments: Assignment 4) and provide a print of the shear (V) and bending moment (M) diagrams.

*Note: The "Find, Given, Solution" format is not required.*

(8%) \*8.4.7 *Note: The horizontal loads at B are a moment couple which can be replaced with an equivalent moment at B.*

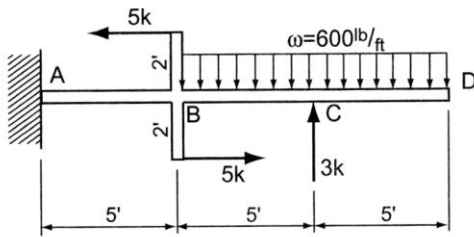

Problem 8.4.7

Partial answers to check with:

$$V_{max} = +3 \text{ k}, M_{max} = -15 \text{ k}\cdot\text{ft}$$

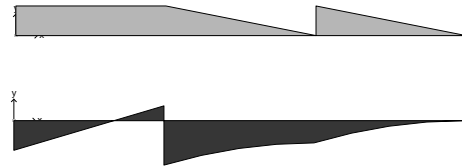

(3%) 4B) For the beam of problem 8.4.7, use Multiframe software to find the shear and bending moment values to verify your work from the semigraphical method. Use the standard steel section you have been assigned which is posted in My Grades on eCampus. Submit the data file (.mfd) on eCampus (under Assignments: Assignment 4) and provide a print of the shear (V) and bending moment (M) diagrams.

*Note: The "Find, Given, Solution" format is not required.*

(10%) \*7.3.4 A heavily loaded floor system uses a composite steel section as shown. A C15 × 40 channel section is attached to the top flange of the W18x50 and a 3 1/2 x 3 x 3/8 angle is attached with the long leg up at the lower left as shown. Determine the location of the centroid, and the  $I_x$  and  $I_y$  about the major centroidal axes using the cross-sectional properties given in the steel tables for standard rolled shapes (see Appendix). (*centroid and moment of inertia*)

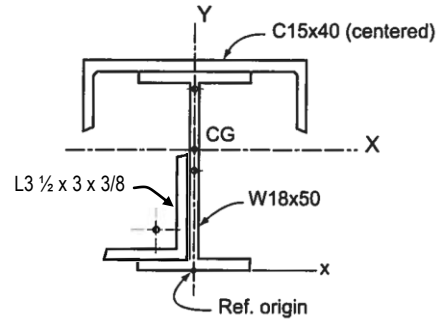

**\*Also calculate the radius of gyration,  $r_x$  and  $r_y$ .**

Problem 7.3.4

Partial answers to check with:

$\hat{x} = -0.0805 \text{ in}$ ,  $\hat{y} = 11.99 \text{ in}$  and must be calculated using the table,  
 $I_x = 1578.8 \text{ in}^4$ ,  $I_y = 393.1 \text{ in}^4$ ,  $r_x = 7.40 \text{ in}$ ,  $r_y = 3.69 \text{ in}$

(5%) \*9.1.9 Select the lightest ~~14" nominal~~ steel W beam to carry the load shown. Assume A992 steel ( $F_b = 33 \text{ ksi}$ ). (*flexural and shear stress*)

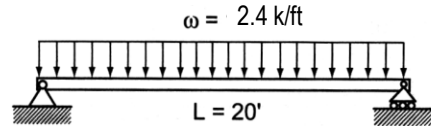

**\*The load is changed to 2.4 k/ft and the depth is not restricted. Also find the maximum shear stress,  $f_v$ . Assume A992 steel ( $F_y = 50 \text{ ksi}$ ,  $F_b = 33 \text{ ksi}$ ).**

Problem 9.1.9

Partial answers to check with:  $S_{req'd} \geq 43.64 \text{ in}^3$ ,  $f_v = 5.5 \text{ ksi}$

(5%) \*9.1.9 Select the lightest ~~14" non~~ sawn timber beam to carry the load shown. Assume A36 steel ( $F_b = 22 \text{ ksi}$ ). (*flexural and shear stress*)

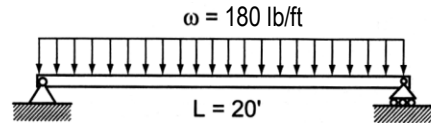

**\*The load is changed to 180 lb/ft. Assume Douglas fir-larch No. 2 ( $F_b = 1450 \text{ psi}$ ). Also find the maximum shear stress,  $f_v$ .**

Problem 9.1.9

Partial answers to check with:  $S_{req'd} \geq 74.5 \text{ in}^3$ ,  $f_v = 58.2 \text{ psi}$

(15%) 9.1.11 Two steel plates (A572,  $F_y = 50 \text{ ksi}$ ) are welded together to form an inverted T-beam. Determine the maximum bending stress developed. Also determine the maximum shear stress at the neutral axis (N.A.) of the cross-section and at the intersection where the stem joins the flange. (*section properties, flexural and shear stress*)

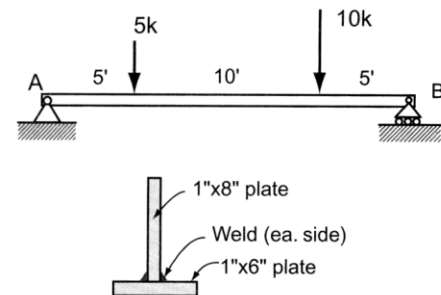

Partial answers to check with:  $\hat{y} = 3.07 \text{ in}$  from bottom,

$I_x = 112.6 \text{ in}^4$ ,  $f_b = 27.6 \text{ ksi}$ ,  
 $f_{v-max} = 1.37 \text{ ksi}$ , ( $Q_{na} = 17.6 \text{ in}^3$ ),  
 $f_{v-joint} = 1.20 \text{ ksi}$  ( $Q = 15.44 \text{ in}^3$ ).

Problem 9.1.11

**MORE NEXT PAGE**

(15%) \*9.1.14 A lintel beam 12' long is used in carrying the imposed loads over a doorway opening. Assuming that a built-up box beam is used with a 12" overall depth as shown, determine the maximum bending stress and shear stress developed. (section properties, flexural and shear stress)

**Use the negative area to find the section properties. Also determine the required pitch spacing for the bottom 2x4 with 1 nail each side (2) with a shear capacity of 300 lb.**

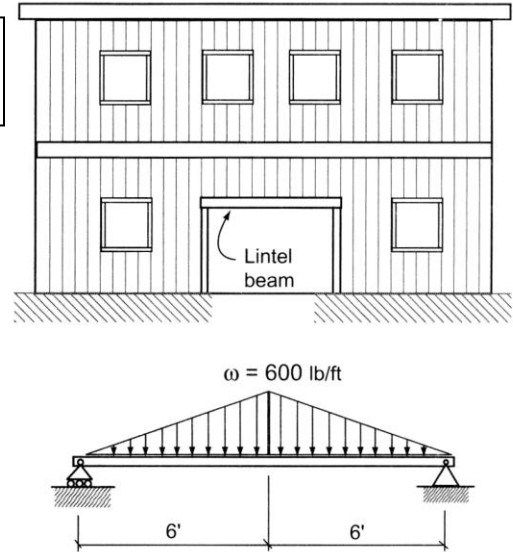
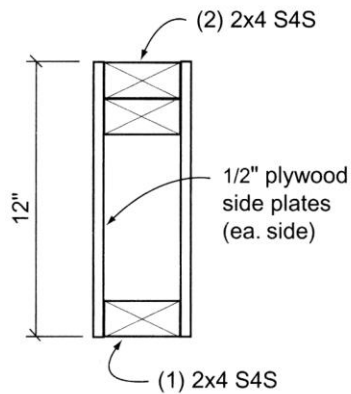

Problem 9.1.14

Partial answers to check with:  $\hat{y} = 6.71 \text{ in}$ ,  $I_x = 496.2 \text{ in}^4$ ,  $f_b = 1168 \text{ psi}$ ,  $f_v = 195 \text{ psi}$   
 ( $Q = 53.8 \text{ in}^3$ ),  $p = 5.3 \text{ in}$ . ( $Q = 31.3 \text{ in}^3$ )

Note: The negative area method is quicker for finding  $I_x$ . There are beam diagram and formula equations for  $V$  and  $M$  in a text example in Chapter 8.