

lecture
four



[http:// nisee.berkeley.edu/godden](http://nisee.berkeley.edu/godden)

point equilibrium and planar trusses

Point Equilibrium 1
Lecture 4

Architectural Structures
ARCH 331

F2009abn

Equilibrium on a Point

- analytically

$$R_x = \sum F_x = 0$$

$$R_y = \sum F_y = 0$$

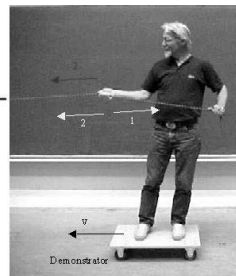
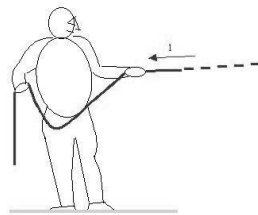

<http://www.physics.umd.edu>

- Newton convinces us it will stay at rest

Point Equilibrium 16
Lecture 4

Foundations Structures
ARCH 331

F2008abn

Equilibrium

- balanced
- steady
- resultant of forces on a particle is 0

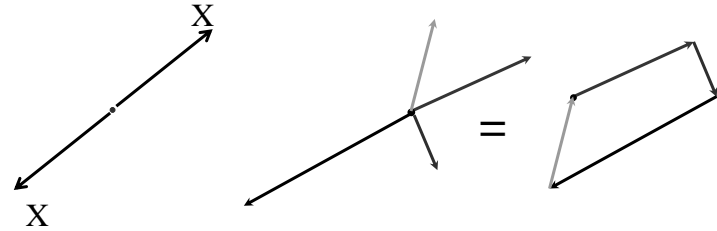

Point Equilibrium 15
Lecture 4

Foundations Structures
ARCH 331

F2008abn

Equilibrium on a Point

- collinear force system

– ex: cables

$$\sum F_{in-line} = 0$$

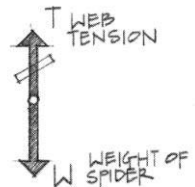

$$\left[R_x = \sum F_x = 0 \quad R_y = \sum F_y = 0 \right]$$

Point Equilibrium 17
Lecture 4

Foundations Structures
ARCH 331

F2008abn

Equilibrium on a Point

- concurrent force system

– ex: cables

$$R_x = \sum F_x = 0$$

$$R_y = \sum F_y = 0$$

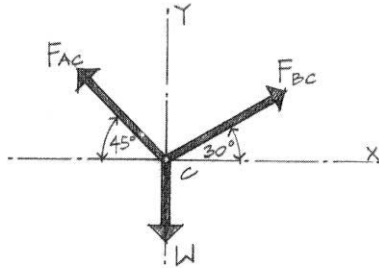

Free Body Diagram

- FBD (sketch)
- tool to see all forces on a body or a point including
 - external forces
 - weights
 - force reactions
 - internal forces

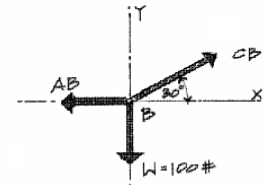

Free Body Diagram

- determine point
- FREE it from:
 - ground
 - supports & connections
- draw all external forces acting ON the body
 - reactions (supporting forces)
 - applied forces
 - gravity

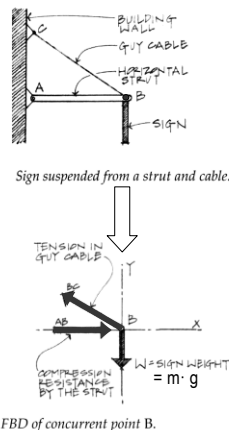

Free Body Diagram

- sketch FBD with relevant geometry
- resolve each force into components
 - known & unknown angles – name them
 - known & unknown forces – name them
- are any forces related to other forces?
- for the unknowns
- write only as many equilibrium equations as needed
- solve up to 2 equations

Free Body Diagram

- solve equations
 - most times 1 unknown easily solved
 - plug into other equation(s)
- common to have unknowns of
 - force magnitudes
 - force angles

Point Equilibrium 22
Lecture 4

Foundations Structures
ARCH 331

F2008abn

Truss Structures

- ancient (?) wood
 - Romans 500 B.C.
- Renaissance revival
- 1800's analysis
- efficient



Point Equilibrium 33
Lecture 4

Foundations Structures
ARCH 331

F2008abn

Truss Structures

– analogous to cables and struts

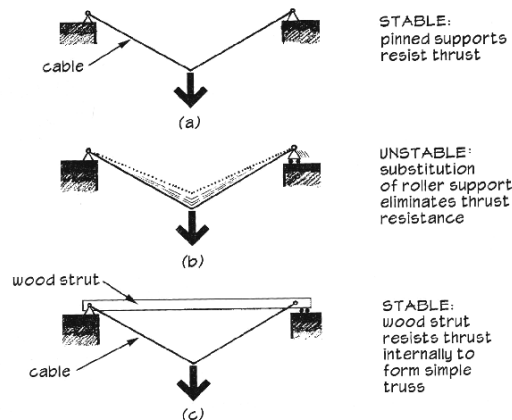

Point Equilibrium 34
Lecture 4

Foundations Structures
ARCH 331

F2008abn

Truss Structures

- comprised of straight members
- geometry with triangles is stable
- loads applied only at pin joints

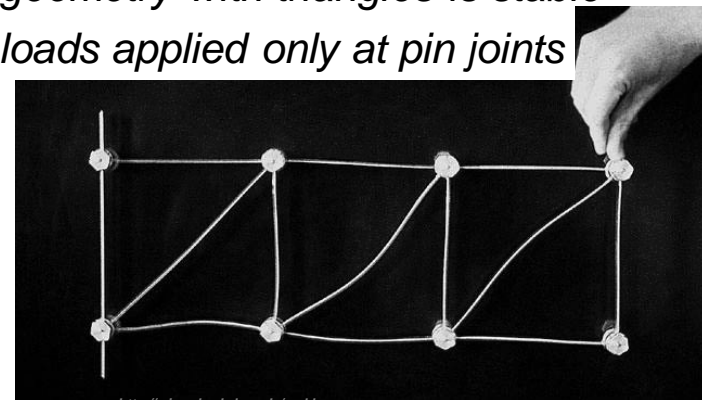

Point Equilibrium 12
Lecture 4

Foundations Structures
ARCH 331

F2009abn

Truss Structures

- 2 force members
 - forces in line, equal and opposite
 - compression
 - tension

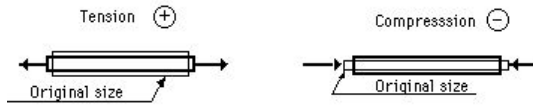

- 3 members connected by 3 joints
- 2 more members need 1 more joint $b = 2n - 3$

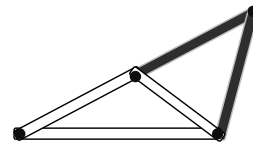

Point Equilibrium 36
Lecture 4

Foundations Structures
ARCH 331

F2008abn

Truss Structures

- compression and tension

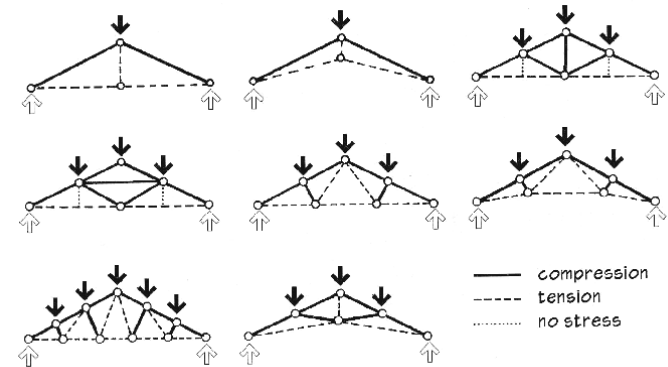

Point Equilibrium 37
Lecture 4

Foundations Structures
ARCH 331

F2008abn

Truss Structures

- statically determinate
- indeterminate
- unstable

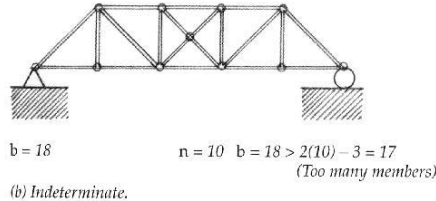
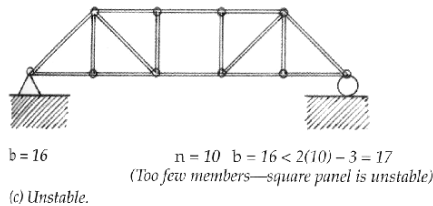
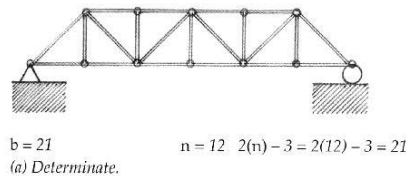

Point Equilibrium 38
Lecture 4

Foundations Structures
ARCH 331

F2008abn

Trusses

- common designs

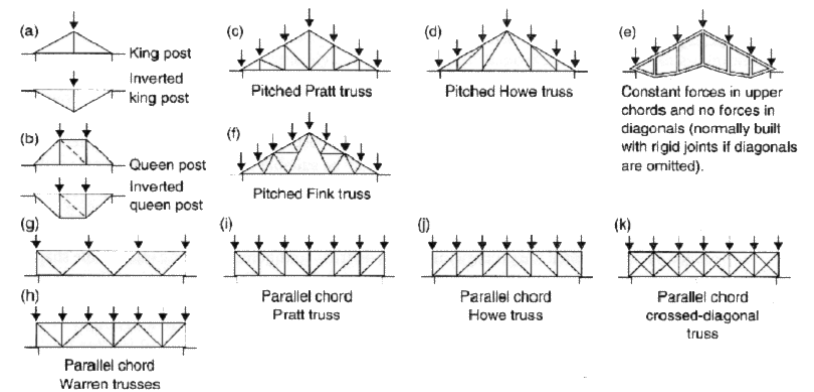

Point Equilibrium 39
Lecture 4

Foundations Structures
ARCH 331

F2008abn

Trusses

- common designs

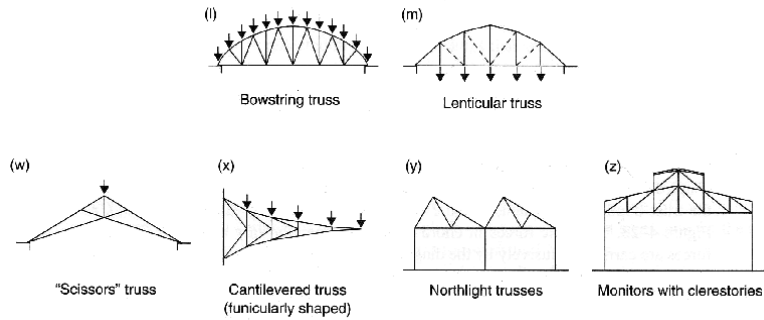

Point Equilibrium 40
Lecture 4

Foundations Structures
ARCH 331

F2008abn

Trusses

- uses
 - roofs & canopies
 - long spans
 - lateral bracing

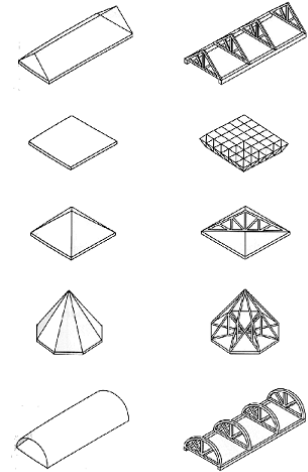
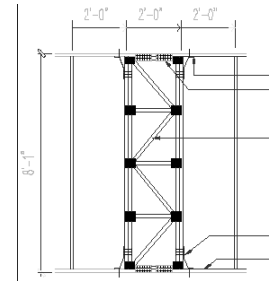

Point Equilibrium 41
Lecture 4

Foundations Structures
ARCH 331

F2008abn

Truss Connections

- "pins"

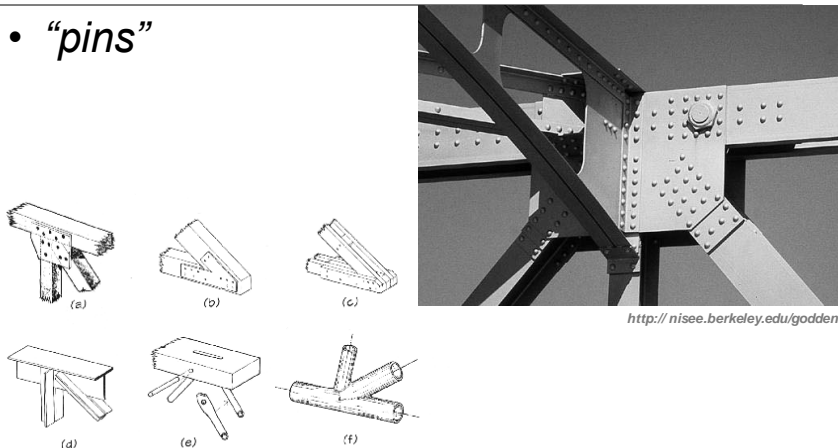

<http://nisee.berkeley.edu/godden>

Figure 4.8: Truss joints.

Point Equilibrium 42
Lecture 4

Foundations Structures
ARCH 331

F2008abn

Sainsbury Center, Foster 1978



Point Equilibrium 43
Lecture 4

Foundations Structures
ARCH 331

F2008abn

Sainsbury Center, Foster 1978

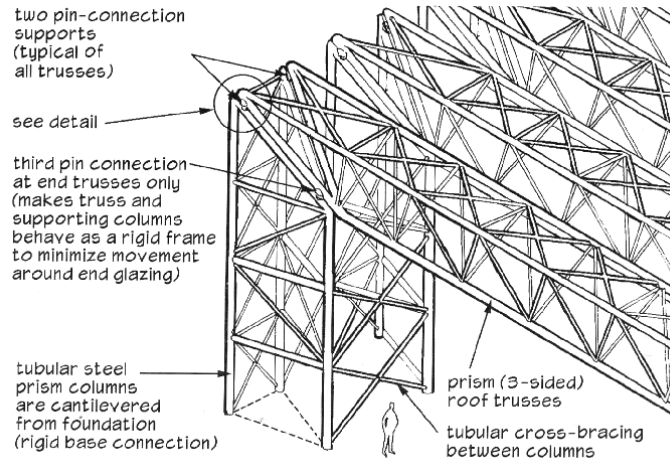

Point Equilibrium 44
Lecture 4

Foundations Structures
ARCH 331

F2008abn

Truss Analysis

- visualize compression and tension from deformed shape

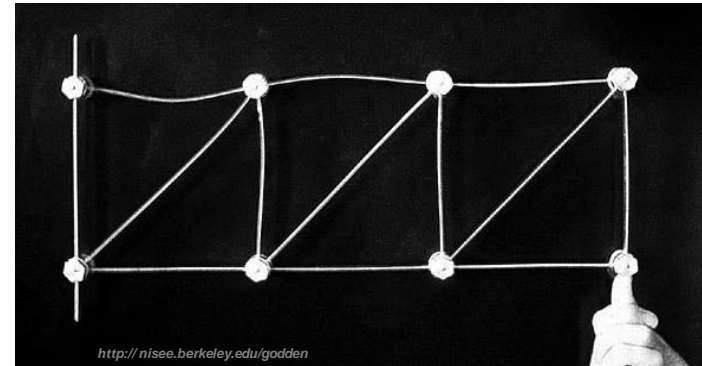

Point Equilibrium 45
Lecture 4

Foundations Structures
ARCH 331

F2008abn

Truss Analysis

- Method of Joints
- Graphical Methods
- Method of Sections
- all rely on equilibrium
 - of bodies
 - internal equilibrium

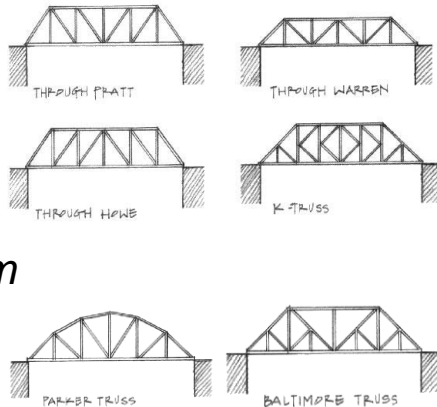

Point Equilibrium 46
Lecture 4

Foundations Structures
ARCH 331

F2008abn

Method of Joints

- isolate each joint
- enforce equilibrium in F_x and F_y
- can find all forces
- long
- easy to mess up

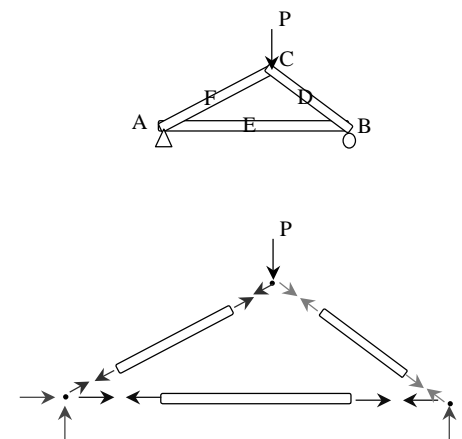

Point Equilibrium 47
Lecture 4

Foundations Structures
ARCH 331

F2008abn

Joint Cases

- two bodies connected

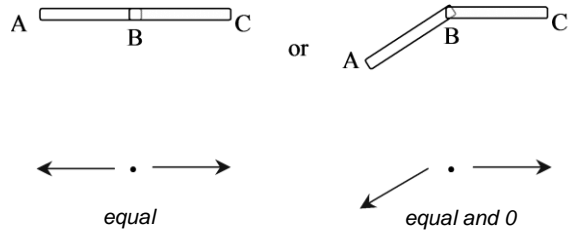

Point Equilibrium 48
Lecture 4

Foundations Structures
ARCH 331

F2008abn

Joint Cases

- three bodies with two in line

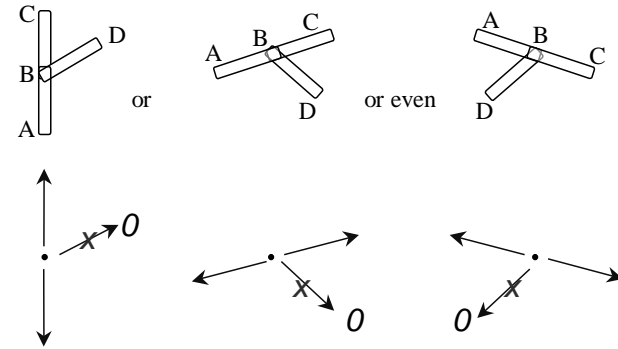

Point Equilibrium 49
Lecture 4

Foundations Structures
ARCH 331

F2008abn

Joint Cases

- crossed

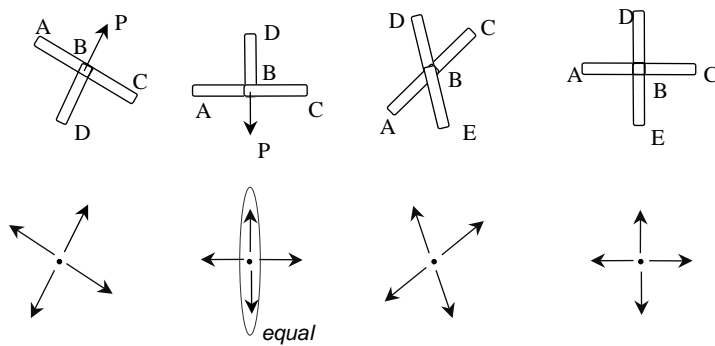

Point Equilibrium 50
Lecture 4

Foundations Structures
ARCH 331

F2008abn

Tools – Multiframe

- in computer lab

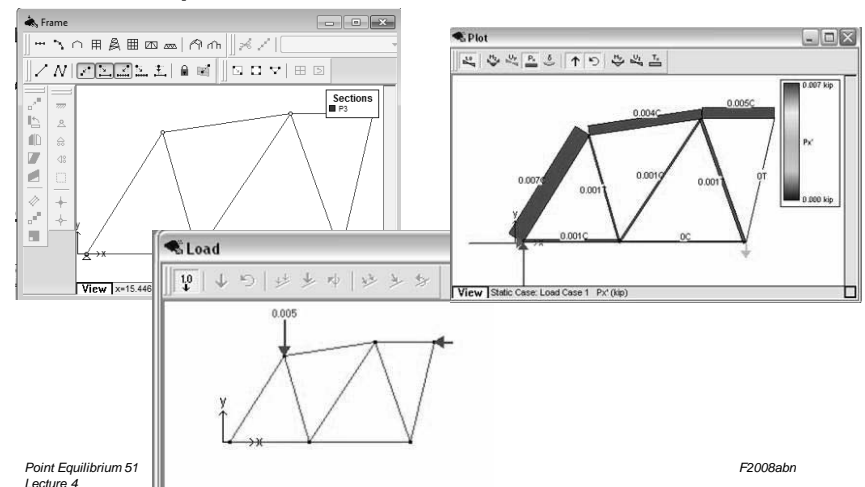

Point Equilibrium 51
Lecture 4

F2008abn

Tools – Multiframe

- *frame window*
 - *define truss members*
 - *or pre-defined truss*
 - *select points, assign supports*
 - *select members, assign section & assign pin ends*
- *load window*
 - *select points, add point load*

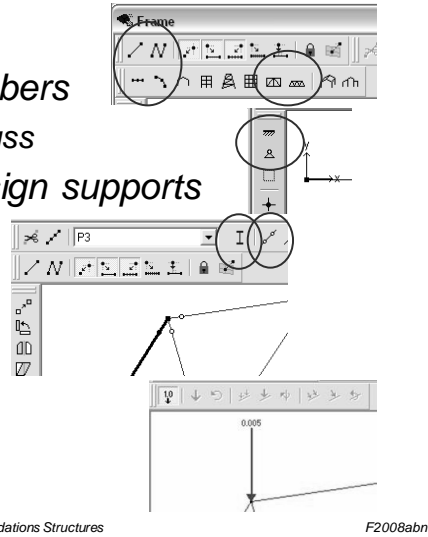

Point Equilibrium 52
Lecture 4

Foundations Structures
ARCH 331

F2008abn

Tools – Multiframe

- *to run analysis choose*
 - *Analyze menu*
 - *Linear*
- *plot*
 - *choose options*
- *results*
 - *choose options*

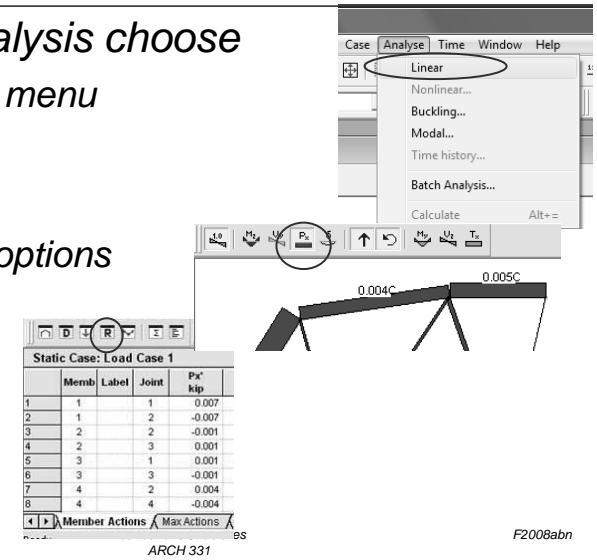

Point Equilibrium 53
Lecture 4

ARCH 331

F2008abn