

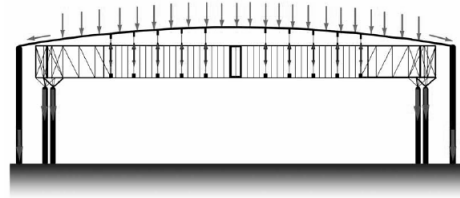

reed.tamu.edu

lecture
 fourteen



system assemblies
 & load tracing

Load Tracing 1
 Lecture 14

Architectural Structures
 ARCH 331

F2012abn

Structural Loads

- gravity acts on mass ($F=m*g$)
- force of mass
 - acts at a point
 - ie. joist on beam
 - acts along a “line”
 - ie. floor on a beam
 - acts over an area
 - ie. people, books, snow on roof or floor

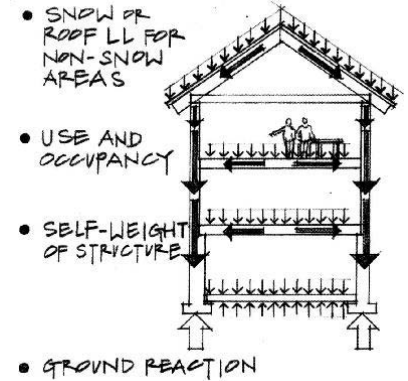

Load Tracing 2
 Lecture 14

Foundations Structures
 ARCH 331

F2008abn

Concentrated Loads

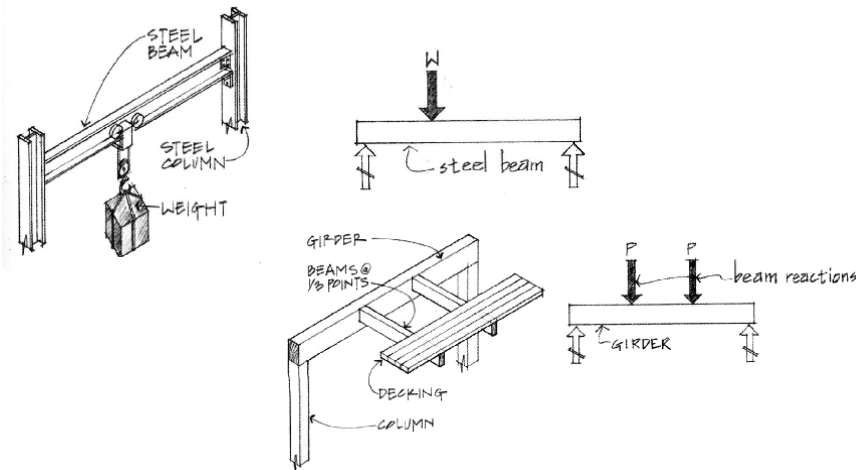

Load Tracing 3
 Lecture 14

Foundations Structures
 ARCH 331

F2008abn

Distributed Loads

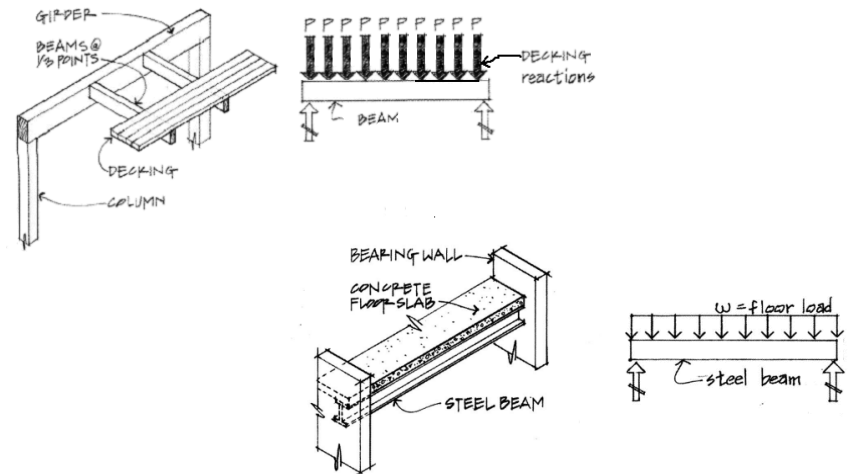

Load Tracing 4
 Lecture 14

Foundations Structures
 ARCH 331

F2008abn

Equivalent Force Systems

- replace forces by resultant
- place resultant where $M = 0$
- using calculus and area centroids

$$W = \int_0^L w dx = \int dA_{\text{loading}} = A_{\text{loading}}$$

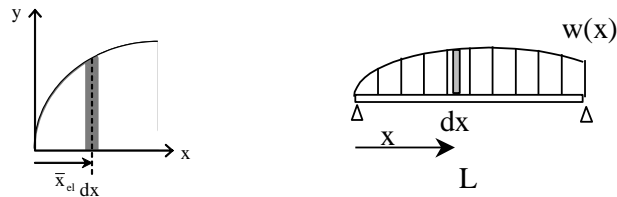

Load Tracing 5
Lecture 14

Foundations Structures
ARCH 331

F2008abn

Area Centroids

- Table 7.1 – pg. 242

Centroids of Common Shapes of Areas and Lines

Shape		\bar{x}	\bar{y}
Triangular area		$\frac{b}{3}$	$\frac{h}{3}$
Quarter-circular area		$\frac{4r}{3\pi}$	$\frac{4r}{3\pi}$
Semicircular area		0	$\frac{4r}{3\pi}$
Semiparabolic area		$\frac{3a}{8}$	$\frac{3h}{5}$
Parabolic area		0	$\frac{3h}{5}$

Load Tracing 6
Lecture 14

Foundations Structures
ARCH 331

F2008abn

Equivalent Load Areas

- area is width \times "height" of load
- w is load per unit length
- W is total load

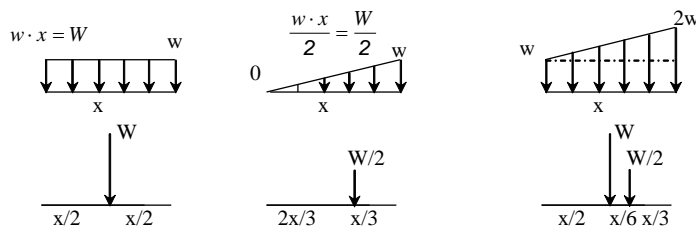

Load Tracing 7
Lecture 14

Foundations Structures
ARCH 331

F2008abn

Distributed Area Loads

- w is also load per unit area

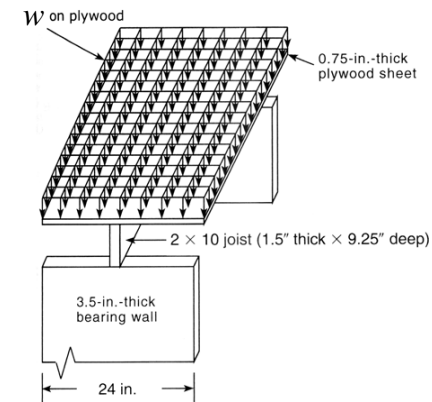

Figure 2.7 Area-distributed load (pressure) on floor decking.

Load Tracing 8
Lecture 14

Foundations Structures
ARCH 331

F2008abn

Load Tracing

- how loads are transferred
 - usually starts at top
 - distributed by supports as actions
 - distributed by tributary areas

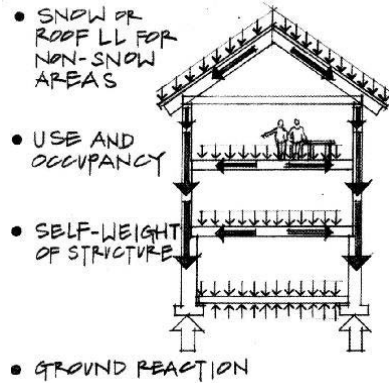

Load Tracing

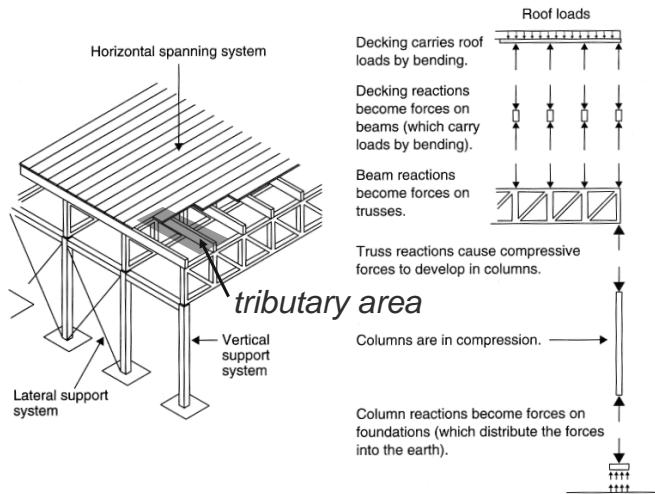

Load Tracing

- areas see distributed area load
- beams or trusses see distributed line loads
- “collectors” see forces
 - columns
 - supports

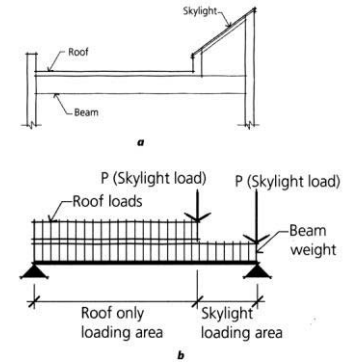

Figs. 1.1a, 1.1b Structural loading diagram of an architectural condition

Load Tracing

- tributary load
 - think of water flow
 - “concentrates” load of area into center

$$w = \left(\frac{\text{load}}{\text{area}} \right) \times (\text{tributary width})$$

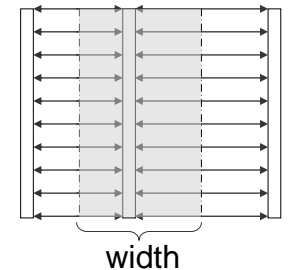

Load Tracing



www.columbia.edu

**Patcenter
Rogers 1986**

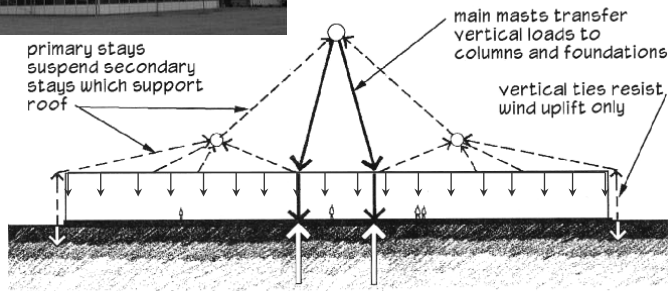

Figure 3.5: Patcenter, load path diagram.

Load Tracing 13
Lecture 14

Foundations Structures
ARCH 331

F2008abn

Load Paths

- floors and framing

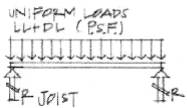

(a) FBD—decking.

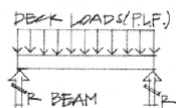

(b) FBD—joists.

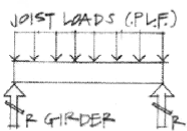

(c) FBD—beams.

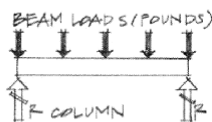

(d) FBD—girder.

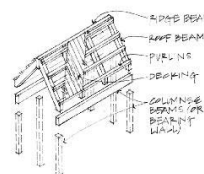
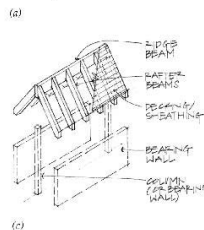
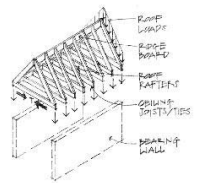

Load Tracing 15
Lecture 14

Foundations Structures
ARCH 331

F2008abn

Load Tracing



http://en.structurae.de

**Alamillo Bridge
Calatrava 1992**

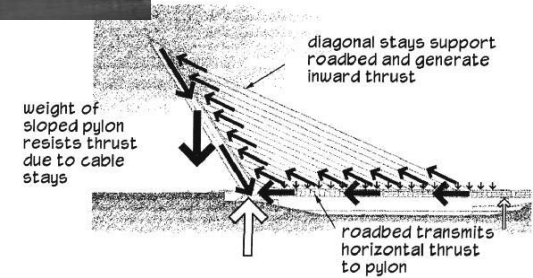

Figure 3.12: Alamillo bridge, load path diagram.

Load Tracing 14
Lecture 14

Foundations Structures
ARCH 331

F2008abn

Load Paths

- wall systems

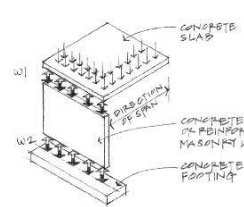

Figure 4.12 Uniform wall load from a slab.

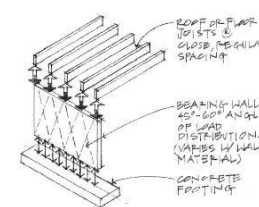

Figure 4.13 Uniform wall load from rafters and joists.

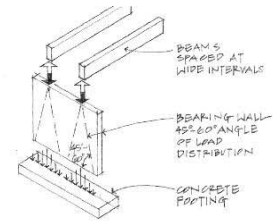

Figure 4.14 Concentrated loads from widely spaced beams.

Load Tracing 16
Lecture 14

Foundations Structures
ARCH 331

F2008abn

Load Paths

- openings & pilasters

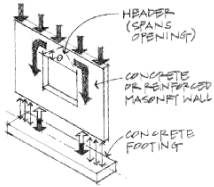

Figure 4.15 Arching over wall openings.

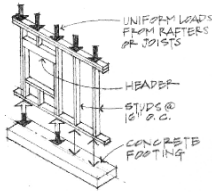

Figure 4.16 Stud wall with a window opening.

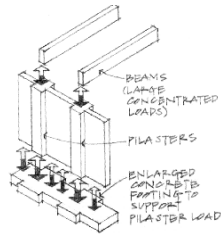

Figure 4.17 Pilasters supporting concentrated beam loads.

Load Tracing 17
Lecture 14

Foundations Structures
ARCH 331

F2008abn

Load Paths

- deep foundations

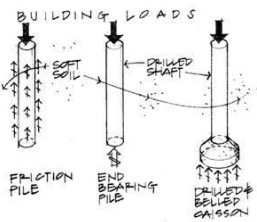

Figure 4.27 Pile foundations.

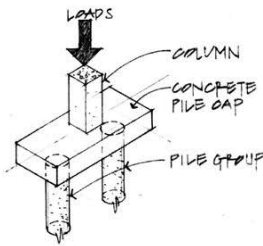

Figure 4.28 Pile cap on one pile group.

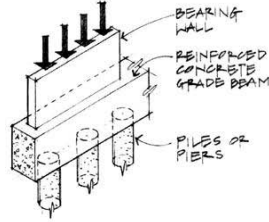

Figure 4.29 Grade beam supporting a bearing wall.

Load Tracing 19
Lecture 14

Foundations Structures
ARCH 331

F2008abn

Load Paths

- foundations

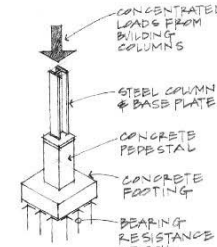

Figure 4.24 Spread footing.

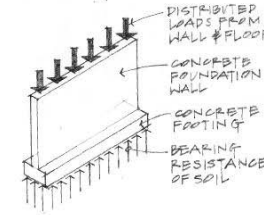

Figure 4.25 Wall footing.

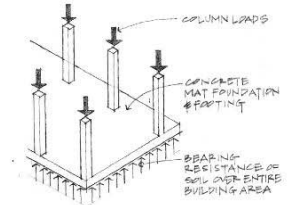

Figure 4.26 Mat or raft foundation.

Load Tracing 18
Lecture 14

Foundations Structures
ARCH 331

F2008abn

Spans

- direction
- depth

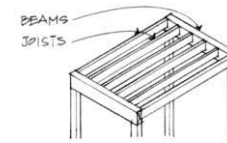

(a) Long, lightly loaded joists bearing on shorter beams create a more uniform structural depth. Space can be conserved if the joists and beams are flush framed.

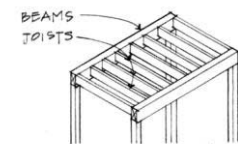

(b) Short joists loading relatively long beams yield shallow joists and deep beams. The individual structural bays are more clearly expressed.

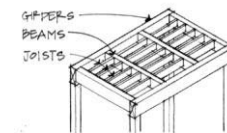

(c) Loads can be reduced on selected beams by introducing intermediate beams.

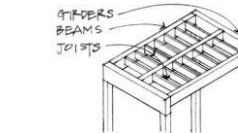

(d) The span capability of the decking material controls the spacing of the joists, while beam spacing is controlled by the allowable joist span.

Load Tracing 20
Lecture 14

Foundations Structures
ARCH 331

F2008abn

Levels

- determine span at top level
- find half way to next element
- *include self weight
- look for “collectors”
- repeat

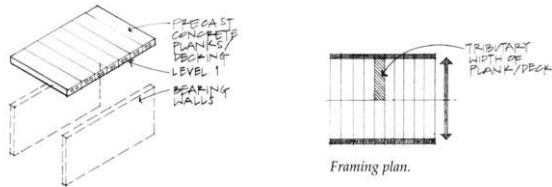

• one:

Levels

• two:

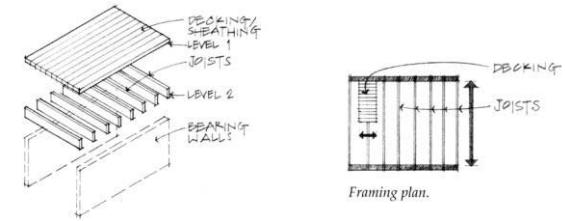

• three:

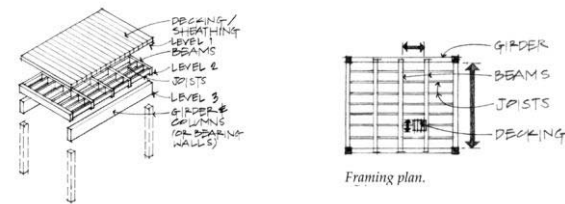

Irregular Configurations

- tracing still 1/2 each side

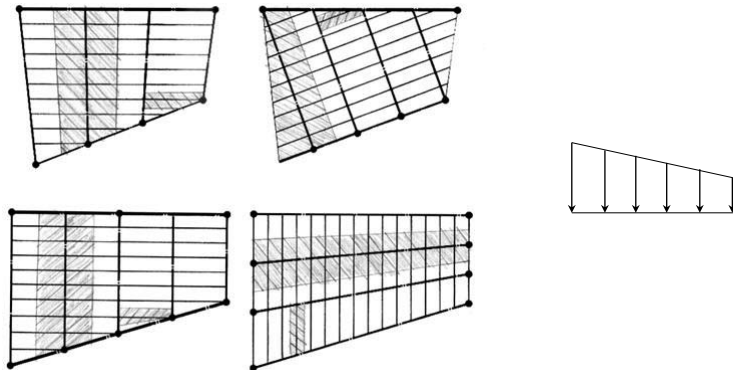

Slabs

- edge support

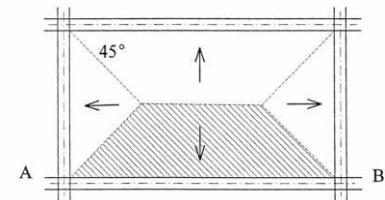

Figure 2-16: Supporting beams' contributing areas for reinforced concrete floor system.

- linear and uniform distribution

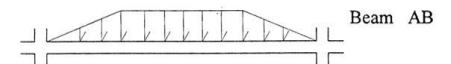

Figure 2-17: Trapezoidal distributed load for Beam AB of Fig. 2-16.

Girders and Transfer

- openings
 - no load & no half way
- girder actions at beam supports

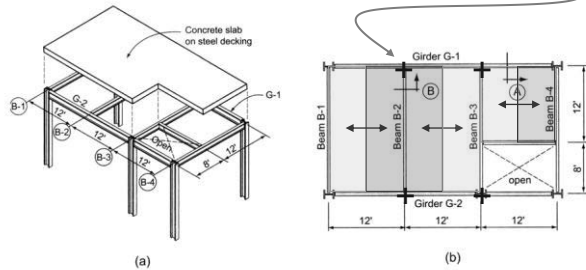

Figure 5.54 (a) Isometric view of partial steel framing arrangement. (b) Partial floor framing—office structure.

Load Tracing 24
Lecture 14

Foundations Structures
ARCH 331

F2008abn

Framing Diagrams

- beam lines and “dots”
- breaks & ends

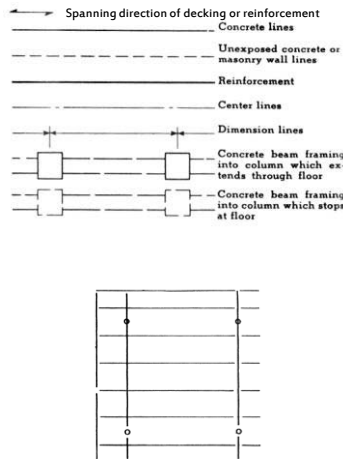
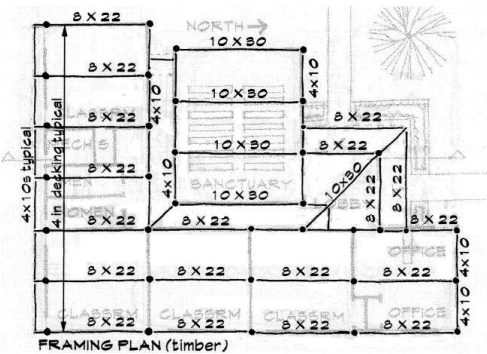

Load Tracing 27
Lecture 14

Architectural Structures
ARCH 331

F2012abn

Sloped Beams

- stairs & roofs
- projected live load
- dead load over length

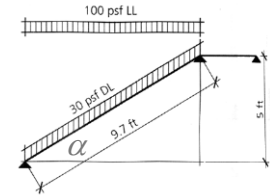

- perpendicular load to beam:

$$W_{\perp} = W \cdot \cos \alpha$$

- equivalent distributed load:

$$W_{adj.} = \frac{W}{\cos \alpha}$$

Load Tracing 58
Lecture 14

Foundations Structures
ARCH 331

F2008abn

Retaining Walls

- purpose
 - retain soil or other material
- basic parts
 - wall & base
 - additional parts

- counterfort
- buttress
- key

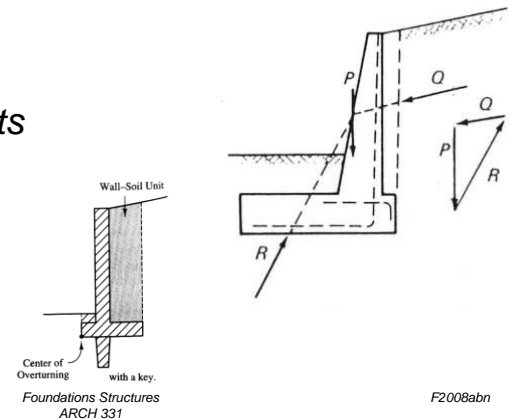

Load Tracing 25
Lecture 14

Foundations Structures
ARCH 331

F2008abn

Retaining Wall Types

- “gravity” wall
 - usually unreinforced
 - economical & simple

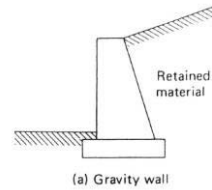

- cantilever retaining wall
 - common

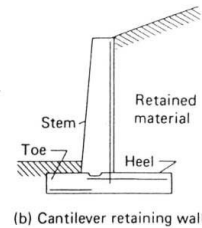

Load Tracing 26
Lecture 14

Foundations Structures
ARCH 331

F2008abn

Retaining Wall Equilibrium

- sliding - overcome friction?
- overturning at toe (o) - overcome mass?

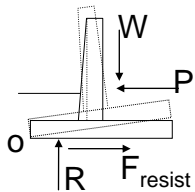

$$SF = \frac{M_{resist}}{M_{overturning}} \geq 1.5 - 2$$

$$SF = \frac{F_{horizontal-resist}}{F_{sliding}} \geq 1.25 - 2$$

Load Tracing 28
Lecture 14

Foundations Structures
ARCH 331

F2008abn

Retaining Wall Loads

- gravity
 - $W = \gamma \times V$
- fluid pressure
 - $p = \omega' \times h$
 - $P = \frac{1}{2} p h$ at $h/3$
- friction
 - $F = \mu \times N$
- soil bearing pressure, q

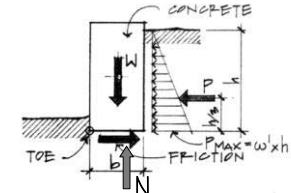

Figure 3.80 FBD of a gravity retaining wall.

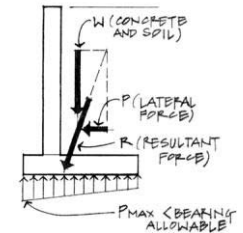

Figure 3.81 Bearing pressure under the wall footing.

Load Tracing 27
Lecture 14

Foundations Structures
ARCH 331

F2008abn

Pressure Distribution

- want resultant of load from pressure inside the middle third of base (kern)
- triangular stress block with p_{max}
- $x = 1/3 \times$ width of stress
- equivalent force location:

$$W \cdot x = \frac{p_{max} \cdot 3x}{2} \cdot \frac{x}{3}$$

$$p_{max} = \frac{2W}{3x} = \frac{2W}{a} \text{ when } a \text{ is fully stressed}$$

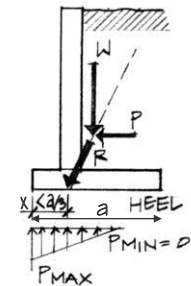

Figure 3.88 Tension possible at the heel.

Load Tracing 29
Lecture 14

Foundations Structures
ARCH 331

F2008abn

Wind Pressure

- distributed load
- “collected” into V
- lateral loads must be resisted

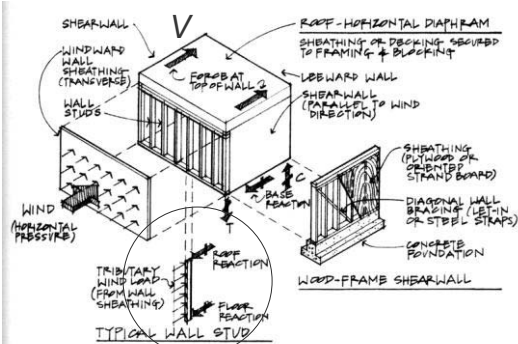

Figure 4.48 Exploded view of a light-framed wood building showing the various lateral resisting components.

Load Tracing 30
Lecture 14

Foundations Structures
ARCH 331

F2008abn

Bracing Configurations

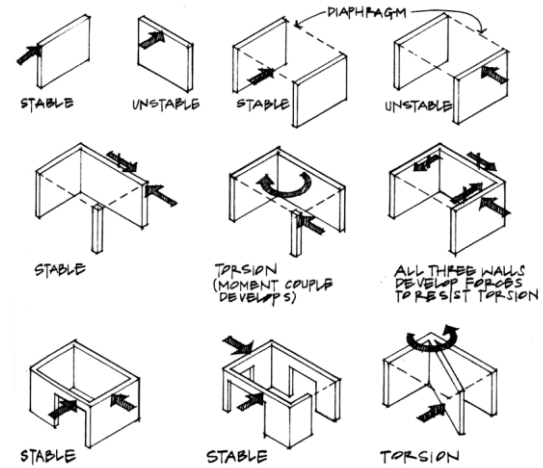

Figure 4.54 Various shearwall arrangements—some stable, others unstable.

Load Tracing 31
Lecture 14

Foundations Structures
ARCH 331

F2008abn