

**ARCHITECTURAL STRUCTURES:  
FORM, BEHAVIOR, AND DESIGN**

**ARCH 331**

**DR. ANNE NICHOLS**

**FALL 2013**

*lecture*  
**twenty eight**

**masonry construction:  
beams & columns**



[www.tamu.edu](http://www.tamu.edu)

# Office Hours

Professor Anne Nichols (845-6540)

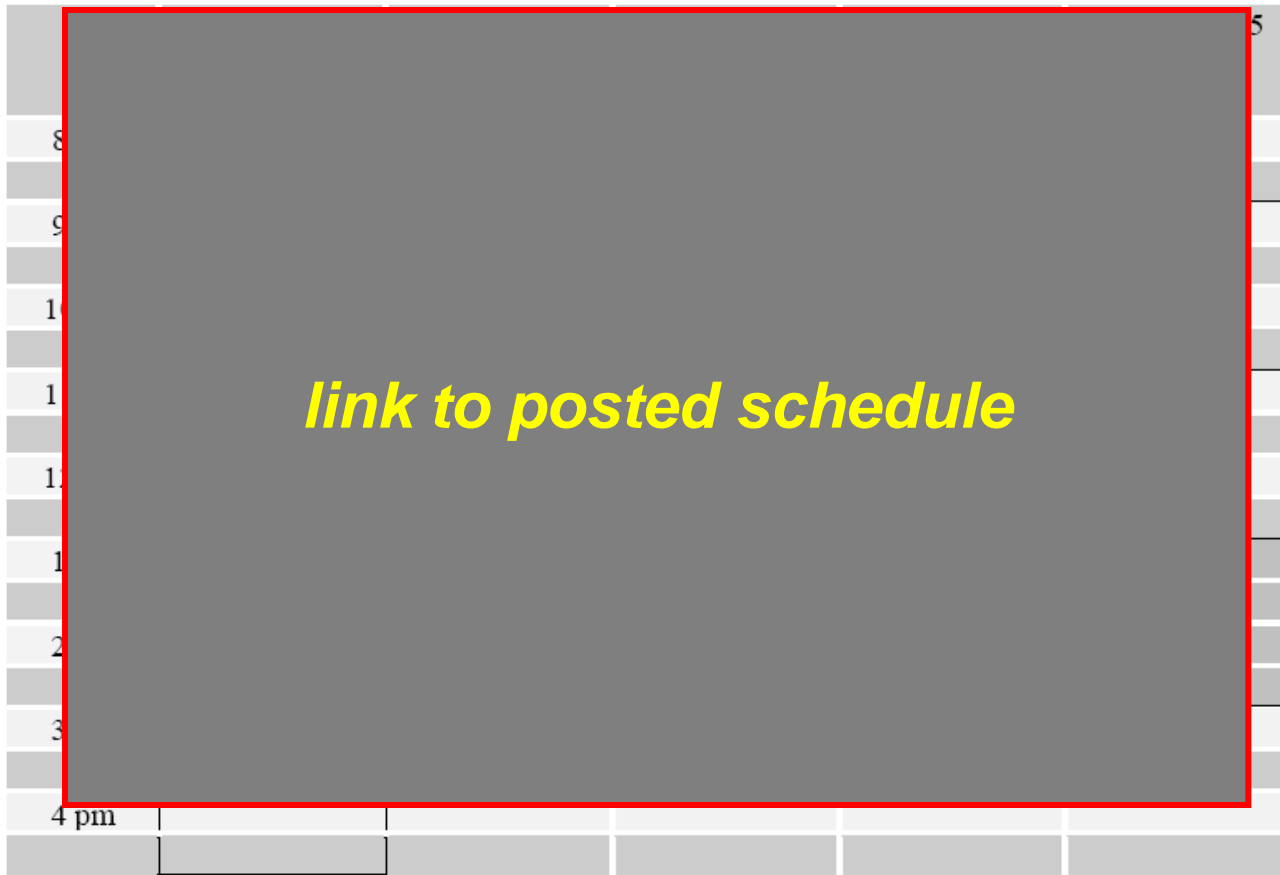

# Masonry Design

- **Masonry Standards Joint Committee**
  - **ACI, ASCE, TMS**
  - **ASD (+empirical)**
    - *linear-elastic stresses*
  - **LRFD added in 2002**
  - **referenced by IBC**
  - **unreinforced allows tension in flexure**
  - **reinforced - all tension in steel**
  - **walls are also in compression**

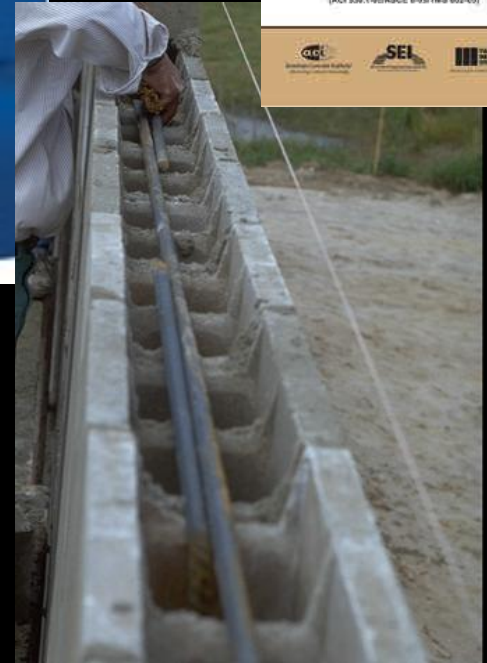

International Masonry Institute (Brian Trimble)

# Masonry Beam & Wall Design

- reinforcement increases capacity & ductility

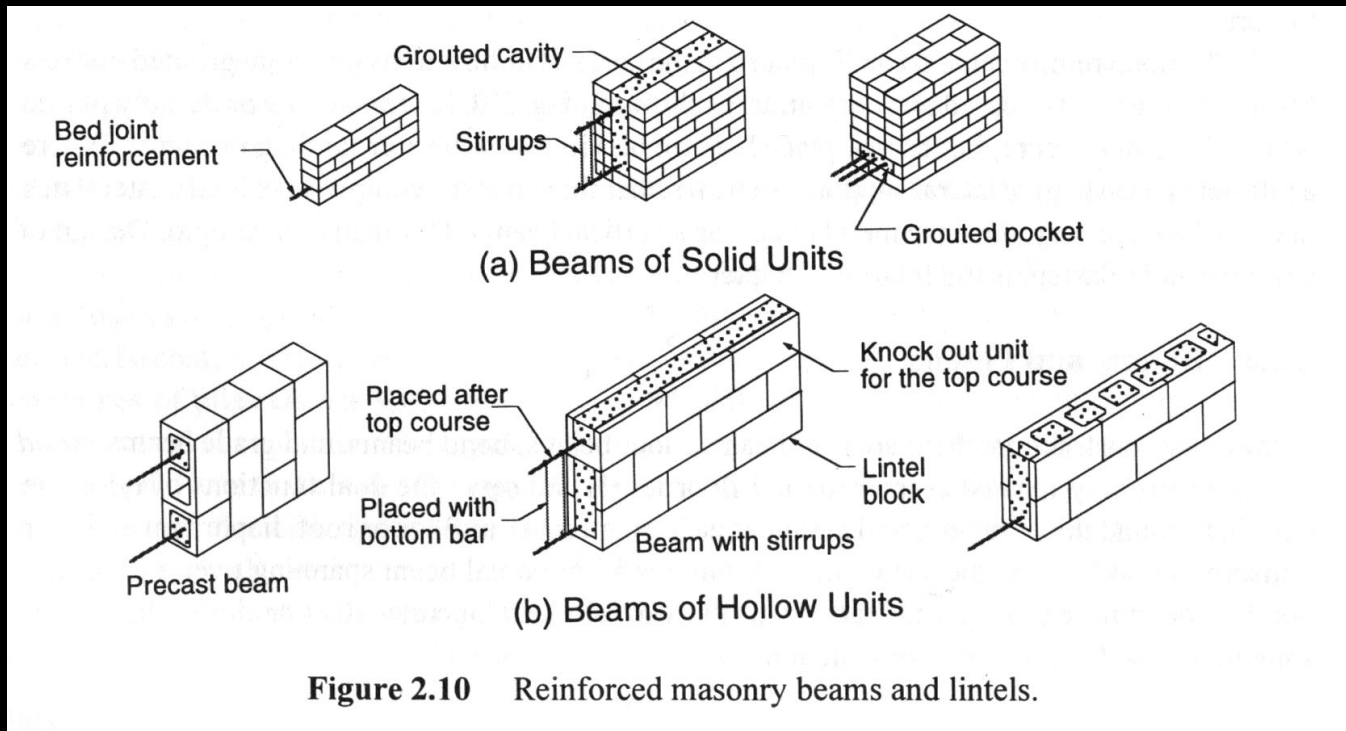

# Masonry Design

- $f_s$  is not the yield stress
- $f_m$  is the stress in the masonry

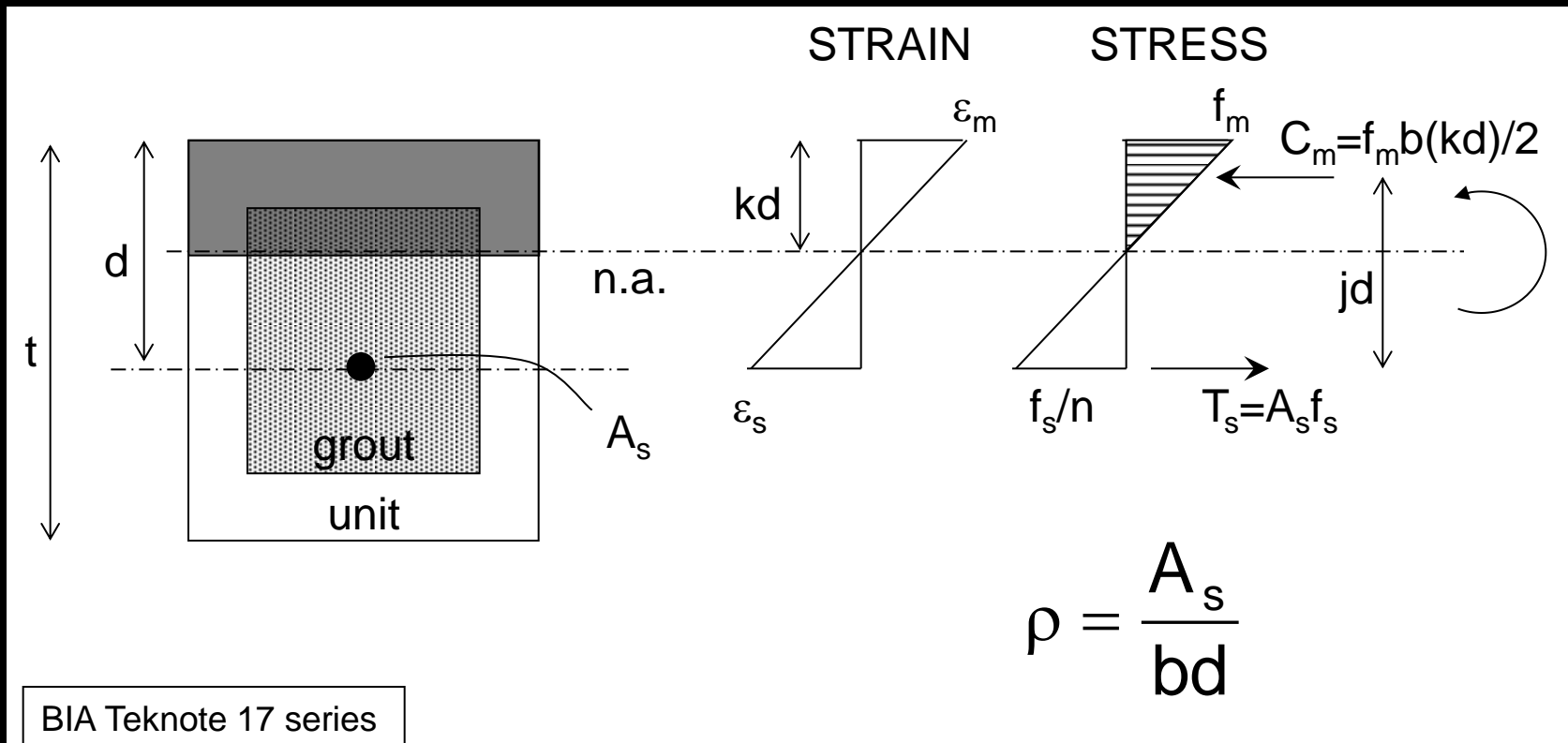

BIA Teknote 17 series

# Masonry Materials

---

- *units*
  - *stone, brick, concrete block, clay tile*



Papercut



Extruded

[www.GlenGerybrick.com](http://www.GlenGerybrick.com)



National Concrete Masonry Association

# Masonry Materials

- *mortar*

- *water,  
masonry cement,  
sand, lime*

- *types:*

- *M* higher strength – 2500 psi (ave.)
- *S* medium high strength – 1800 psi
- *N* medium strength – 750 psi
- *O* medium low strength – 350 psi
- *K* low strength – 75 psi



National Concrete  
Masonry Association



# Masonry Materials

- rebar
- grout
  - fills voids and fixes rebar
- prisms
  - used to test strength,  
 $f'_m$
- fire resistant



Ryan-Briggs Associates



National Concrete Masonry Association



# Masonry Materials

- *moisture resistance*
  - *weathering index for brick*
  - *bond and detailing*
  - *expansion or shrinking from water*
    - *provide control joints*
    - *parapets, corners, long walls*

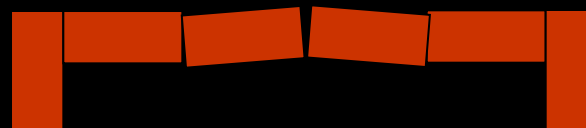
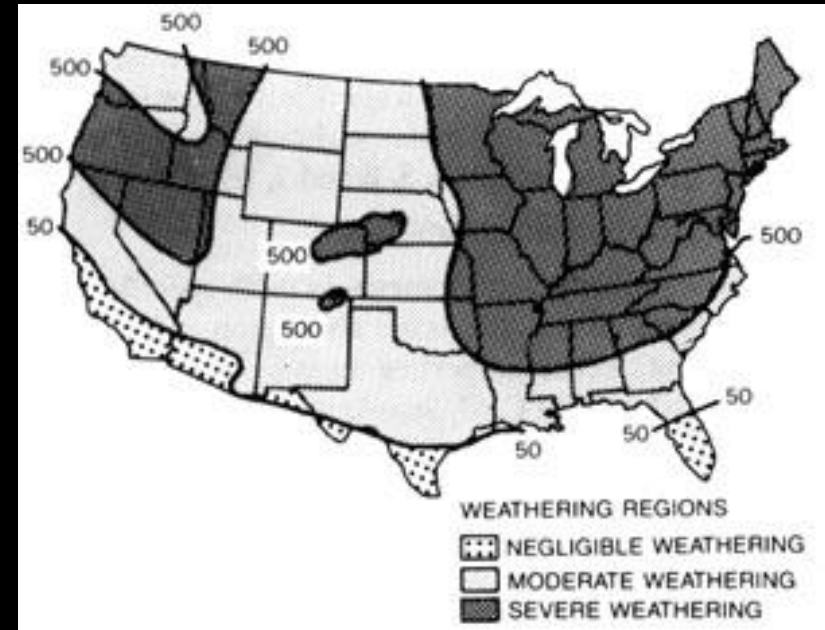

*parapet with no control joint*

# Allowable Masonry Stresses

- *tension - unreinforced only*

Table 2.2.3.2 — Allowable flexural tensile stresses for clay and concrete masonry, psi (kPa)

Direction of flexural tensile stress and masonry type	Mortar types			
	Portland cement/lime or mortar cement		Masonry cement or air entrained portland cement/lime	
	M or S	N	M or S	N
Normal to bed joints				
Solid units	53 (366)	40 (276)	32 (221)	20 (138)
Hollow units <sup>1</sup>				
UngROUTed	33 (228)	25 (172)	20 (138)	12 (83)
Fully grouted	86 (593)	84 (579)	81 (559)	77 (531)
Parallel to bed joints in running bond				
Solid units	106 (731)	80 (552)	64 (441)	40 (276)
Hollow units				
UngROUTed and partially grouted	66 (455)	50 (345)	40 (276)	25 (172)
Fully grouted	106 (731)	80 (552)	64 (441)	40 (276)
Parallel to bed joints in masonry not laid in running bond				
Continuous grout section parallel to bed joints	133 (917)	133 (917)	133 (917)	133 (917)
Other	0 (0)	0 (0)	0 (0)	0 (0)

<sup>1</sup> For partially grouted masonry, allowable stresses shall be determined on the basis of linear interpolation between fully grouted hollow units and ungrouted hollow units based on amount (percentage) of grouting.

# Masonry Walls

tension normal to bed joints

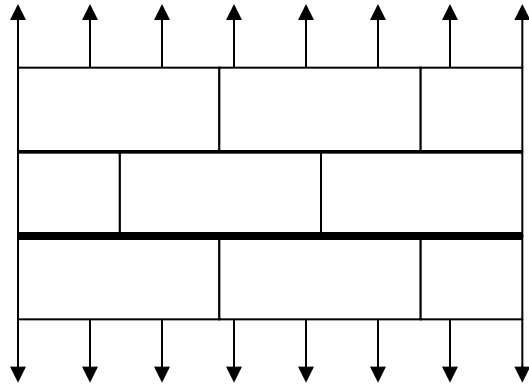

**WALLS**

Not allowed in  
MSJC code

tension parallel to bed joints

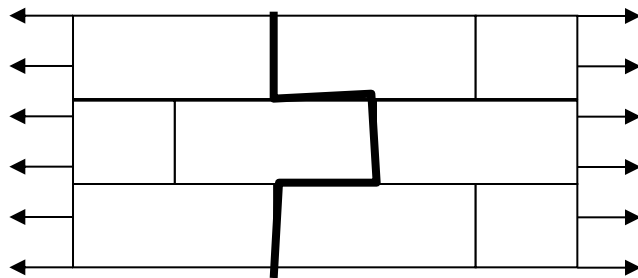

strong units

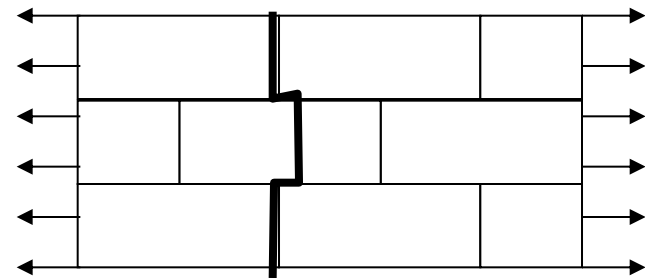

weak units

# Allowable Masonry Stresses

---

- *flexure*

- $F_b = 1/3 f'_m$  (unreinforced)

- $F_b = 0.45 f'_m$  (reinforced)

- *shear, unreinforced masonry*

- $F_v = 1.5 \sqrt{f'_m} \leq 120 \text{ psi}$

- *shear, reinforced masonry*

- $M/Vd \leq 0.25:$   $F_v = 3.0 \sqrt{f'_m}$

- $M/Vd \geq 1.0:$   $F_v = 2.0 \sqrt{f'_m}$

# Allowable Reinforcement Stress

---

- *tension*
  - a) *Grade 40 or 50*      $F_s = 20 \text{ ksi}$
  - b) *Grade 60*              $F_s = 32 \text{ ksi}$
  - c) *Wire joint*              $F_s = 30 \text{ ksi}$
  
- *\*no allowed increase by 1/3 for combinations with wind & earthquake – did before 2011 MSJC code*

# Reinforcement, $M_s$

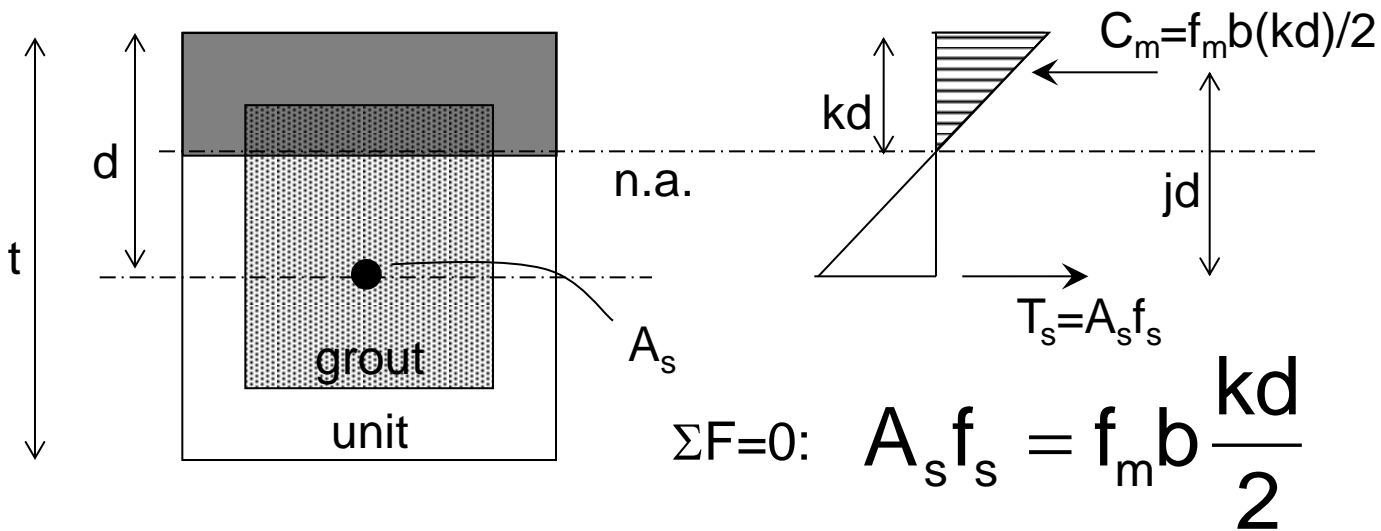

$$\Sigma M \text{ about } C_m: M_s = A_s f_s jd = \rho b d^2 j f_s$$

if  $f_s = F_s$  (allowable) the moment capacity is limited by the steel

MSJC:  $F_s = 20 \text{ ksi}, 24 \text{ ksi}$  or  $30 \text{ ksi}$  by type



# Reinforcement, $M_m$

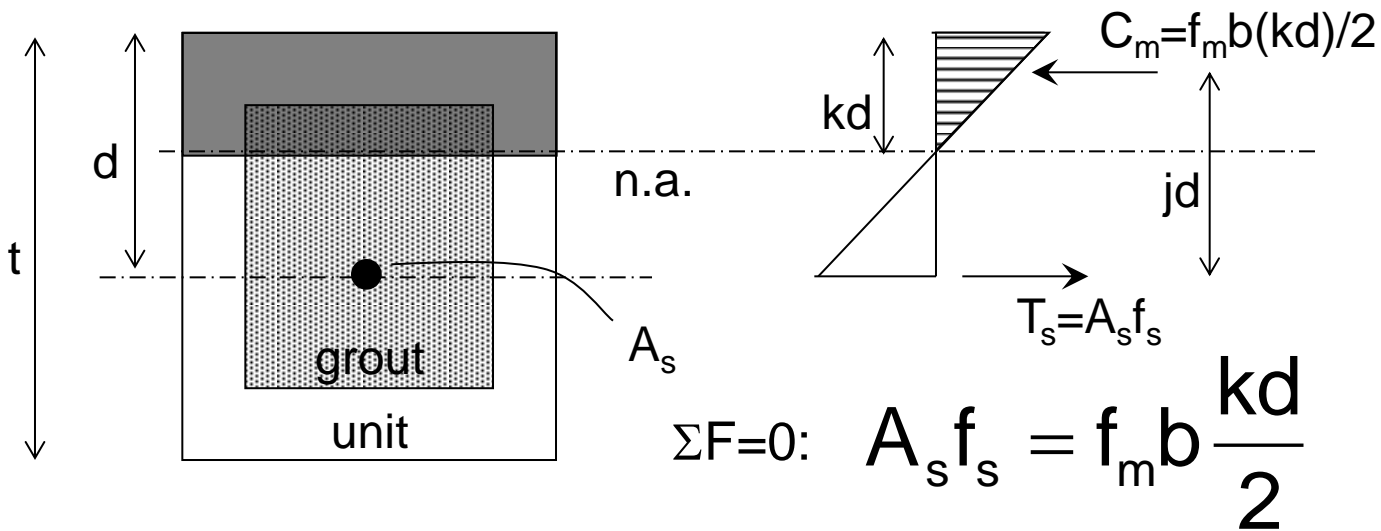

$$\Sigma M \text{ about } T_s: M_m = f_m b \frac{kd}{2} jd = 0.5 f_m b d^2 jk$$

if  $f_s = F_s$  (allowable) the moment capacity is limited by the steel

$$\text{MSJC } F_b = 0.33 f'_m$$

# Masonry Lintels

- distributed load
  - triangular or trapezoidal

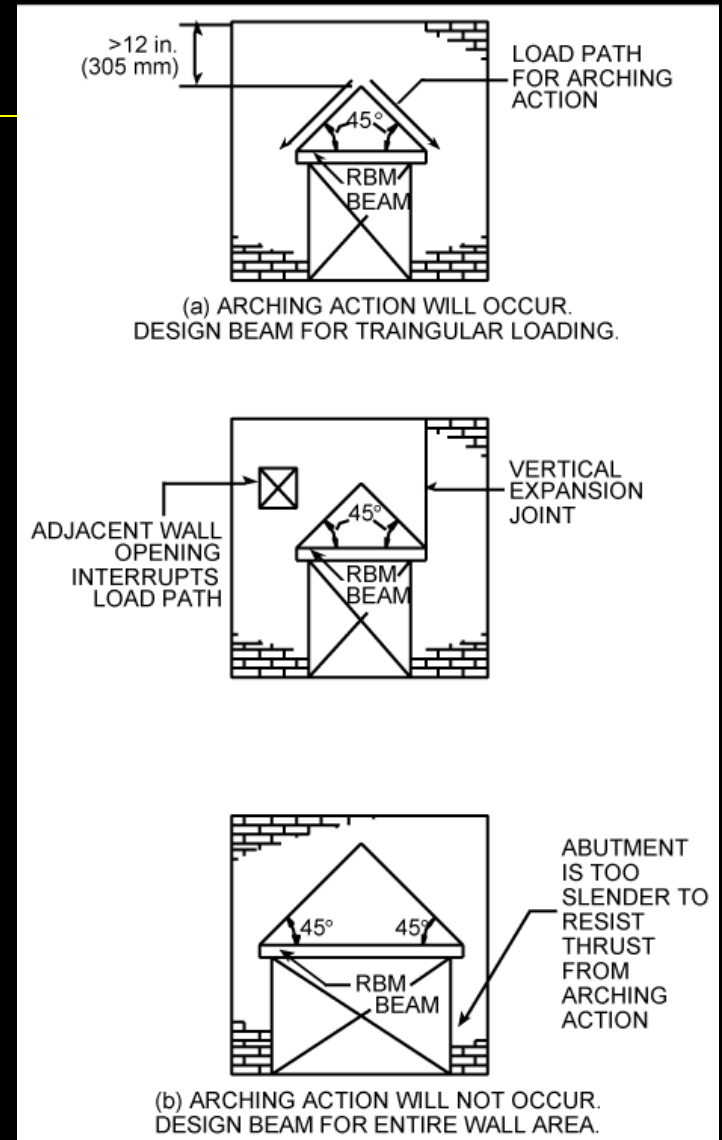
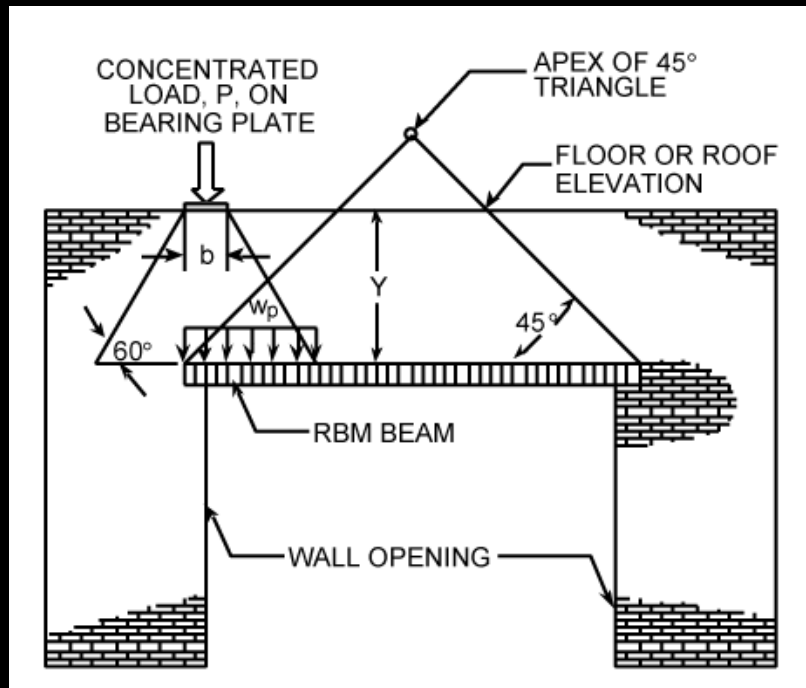

# Strategy for RM Flexural Design

---

- to size section and find reinforcement

- find  $\rho_b$  knowing  $f'_m$  and  $f_y$

- size section for some  $\rho < \rho_b$

- get  $k, j$

- $bd^2 = \frac{M}{\rho j F_s}$

needs to be sized  
for shear also

- get  $b$  &  $d$  in nice units

- size reinforcement (bar size & #):  $A_s = \frac{M}{F_s j d}$

- check design:  $M_s = A_s F_s j d > M$

$$f_b = \frac{M}{0.5bd^2 jk} < F_b$$

# Ultimate Strength Design

- LRFD
- like reinforced concrete
- useful when beam shear is high
- improved inelastic model
  - ex. earthquake loads

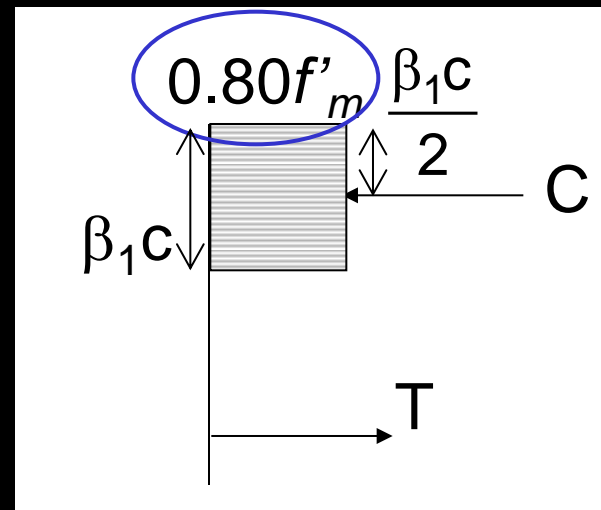

# Masonry Columns and Pilasters

- *must be reinforced*

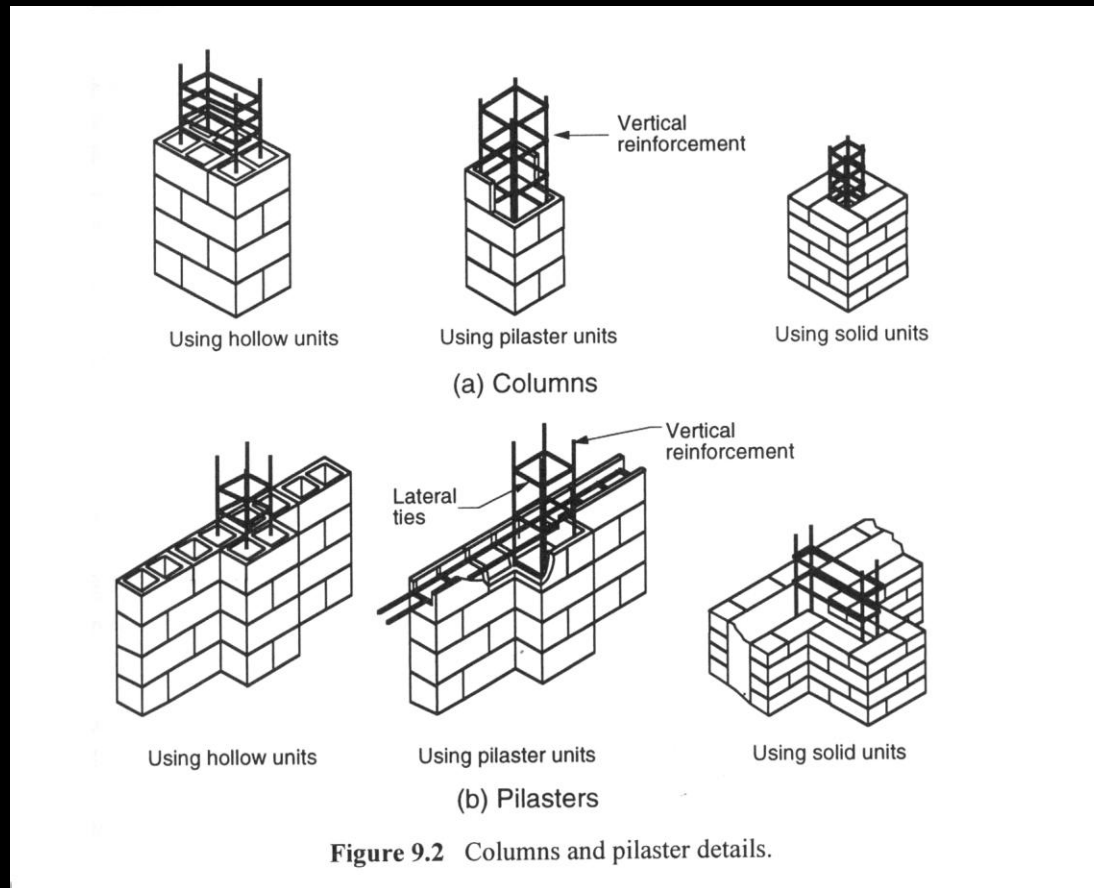

# Masonry Columns and Pilasters

---

- *considered a column when*
  - $b/t < 3$  and  $h/t > 4$* 
    - *b is width of “wall”*
    - *t is thickness of “wall”*
- *slender is*
  - *8” one side*
  - *$h/t \leq 25$*
- *needs ties*
- *eccentricity may be required*





# Masonry Columns

– allowable axial load

$$P_a = \left[ 0.25 f'_m A_n + 0.65 A_{st} F_s \right] \left[ 1 - \left( \frac{h}{140r} \right)^2 \right]$$

$h/r \leq 99$

$$P_a = \left[ 0.25 f'_m A_n + 0.65 A_{st} F_s \right] \left( \frac{70r}{h} \right)^2$$

$h/r > 99$

$h$  = effective length

$r$  = radius of gyration

$A_n$  = effective area of masonry

$A_{st}$  = effective area of column reinforcement

$F_s$  = allowable compressive stress in column reinforcement

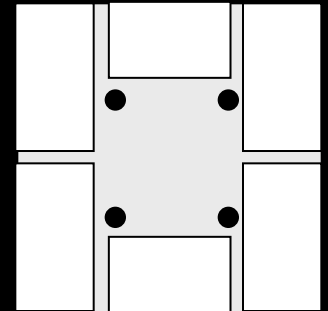

# Masonry Walls (unreinforced)

– allowable axial stresses

$$F_a = 0.25 f'_m \left[ 1 - \left( \frac{h}{140r} \right)^2 \right]$$

$h/r \leq 99$

$$F_a = 0.25 f'_m \left( \frac{70r}{h} \right)^2$$

$h/r > 99$

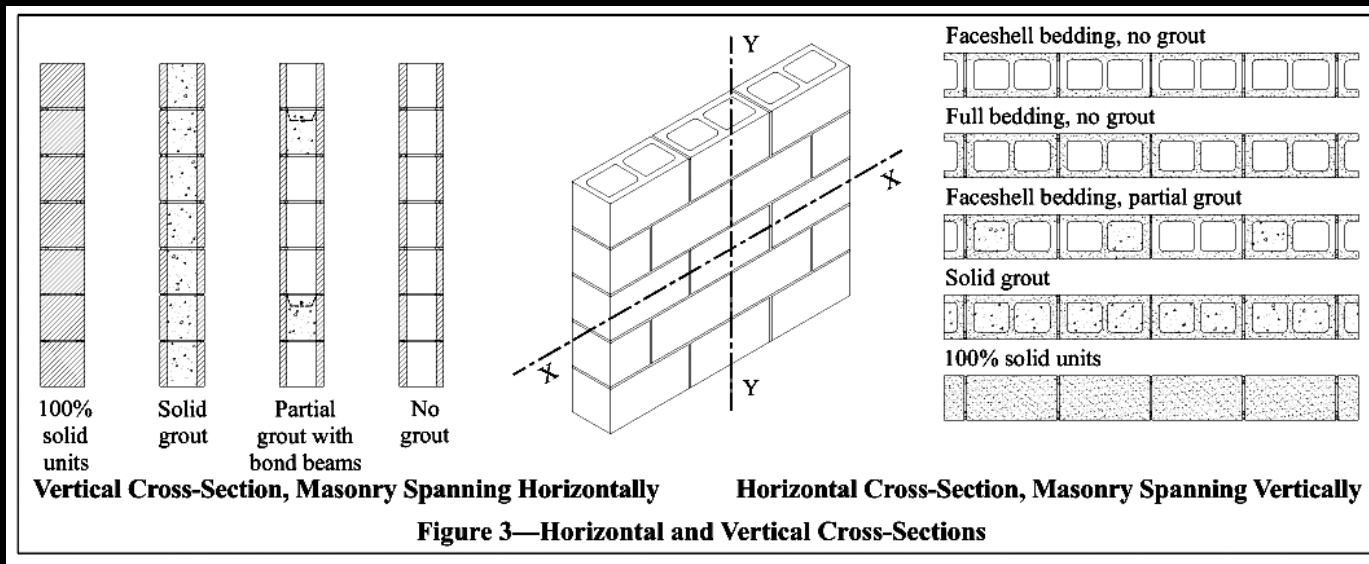

# Design

---

- *masonry columns and walls (unreinforced)*

$$\frac{f_a}{F_a} + \frac{f_b}{F_b} \leq 1.0 \quad \text{and} \quad f_b - f_a \leq F_t$$

$$- h/r < 99 \quad F_a = 0.25 f'_m \left[ 1 - \left( \frac{h}{140r} \right)^2 \right]$$

$$- h/r > 99 \quad F_a = 0.25 f'_m \left( \frac{70r}{h} \right)^2$$

$$F_b = 0.33 f'_m$$

# Design

- *masonry columns and walls - loading*
  - *wind loading*
  - *eccentric axial load*
  - *“virtual” eccentricity,  $e_1$*

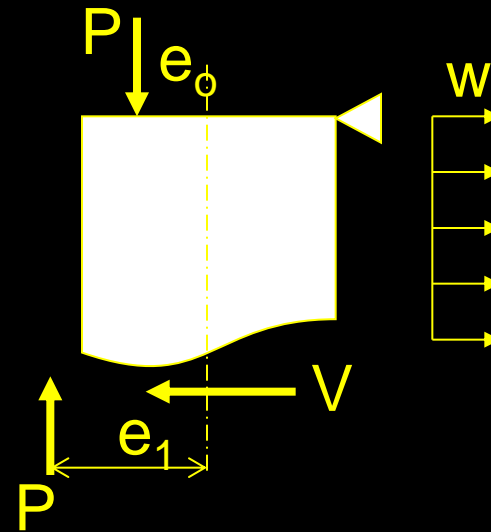
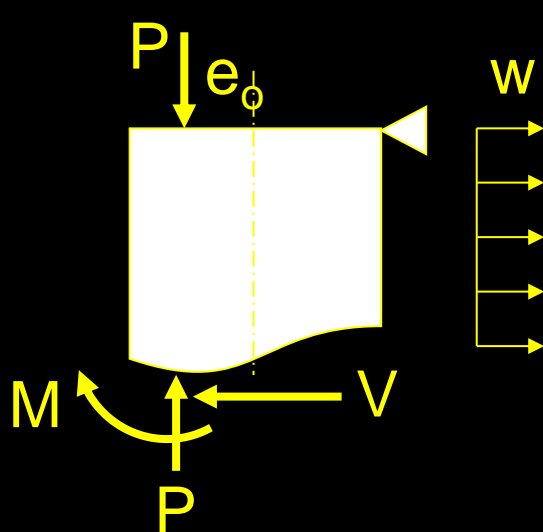
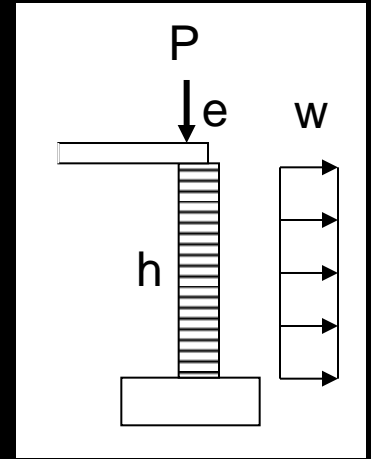

$$e_1 = \frac{M}{P}$$

virtual eccentricity

# Design

- *masonry columns and walls – with rebar*
  - *wall reinforcement usually at center and ineffective in compression*

$$f_a + f_b \leq F_b \quad \text{provided} \quad f_a \leq F_a$$

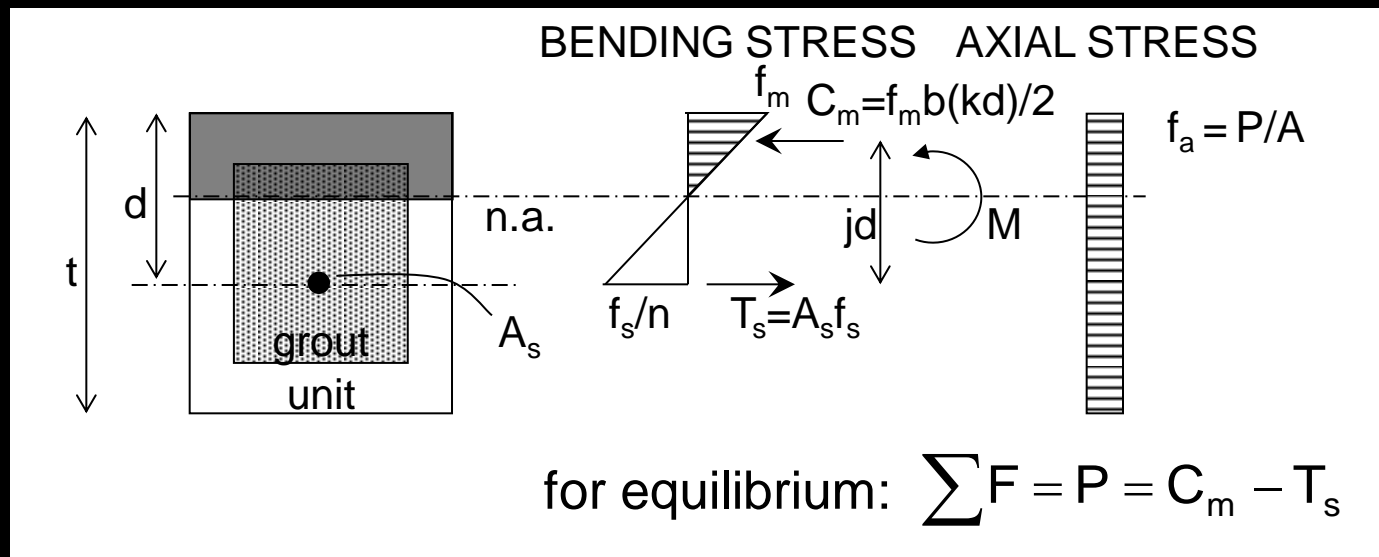

# Design Steps Knowing Loads

1. *assume limiting stress*
  - *buckling, axial stress, combined stress*
2. *solve for  $r$ ,  $A$  or  $S$*
3. *pick trial section*
4. *analyze stresses*
5. *section ok?*
6. *stop when section is ok*

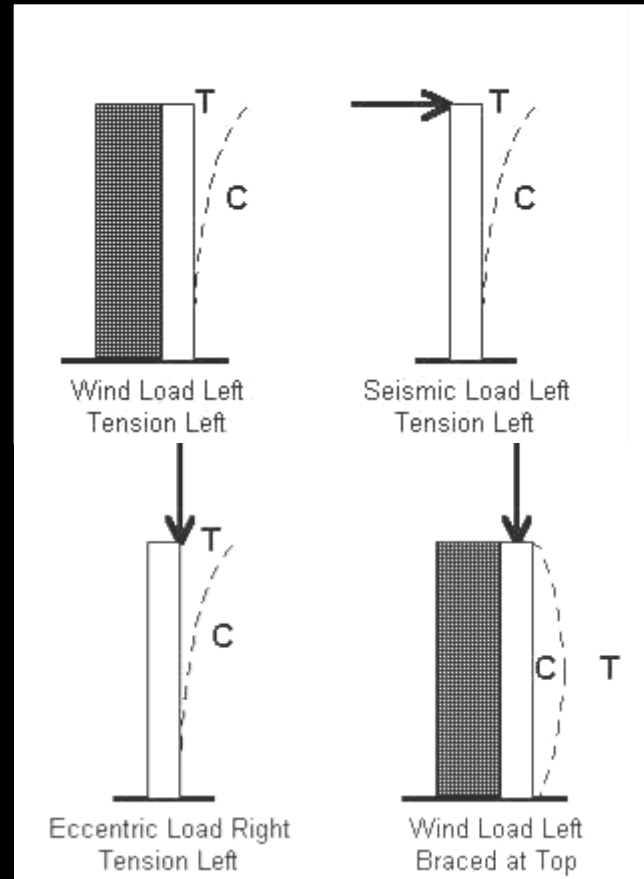



# *Final Exam Material*

---

- *my list:*
  - *systems*
    - *components & levels*
    - *design considerations*
  - *equilibrium -  $\Sigma F$  &  $\Sigma M$* 
    - *supports, trusses, cables, beams, pinned frames, rigid frames*
  - *materials*
    - *strain & stress ( $E$ ), temperature, constraints*

# Final Exam Material

---

- *my list (continue):*
  - *beams*
    - *distributed loads, tributary width, V&M, stresses, design, section properties (I & S), pitch, deflection*
  - *columns*
    - *stresses, design, section properties (I & r)*
  - *frames*
    - *P, V & M, P- $\Delta$ , effective length with joint stiffness, connection design, tension member design*

# *Final Exam Material*

---

- *my list (continued):*
  - *foundations*
    - *types*
    - *sizing & structural design*
    - *overturning and sliding*
  - *design specifics*
    - *steel (ASD & LRFD)*
    - *concrete*
    - *wood*
    - *masonry*