

## Stress and Strain – Elasticity

### Notation:

<p><math>A</math> = area</p> <p><math>D</math> = diameter dimension</p> <p><math>E</math> = modulus of elasticity or Young's modulus</p> <p><math>f</math> = stress</p> <p><math>F_{allow.}</math> = allowable stress</p> <p><math>F_t</math> = allowable tensile stress</p> <p><math>F.S.</math> = factor of safety</p> <p><math>h</math> = height</p> <p><math>kPa</math> = kilopascals or <math>1 \text{ kN/m}^2</math></p> <p><math>ksi</math> = kips per square inch</p> <p><math>L</math> = length</p> <p><math>LRFD</math> = load and resistance factor design</p> <p><math>MPa</math> = megapascals or <math>10^6 \text{ N/m}^2</math> or <math>1 \text{ N/mm}^2</math></p> <p><math>q</math> = allowable soil bearing pressure</p> <p><math>psf</math> = pounds per square foot</p> <p><math>P</math> = name for axial force vector</p> <p><math>R</math> = name for design quantity (force or moment) for LRFD, ex. <math>R_L</math>, <math>R_D</math>, or <math>R_n</math></p>	<p><math>t</math> = thickness</p> <p><math>\delta</math> = elongation or length change</p> <p><math>\varepsilon</math> = strain</p> <p><math>\phi</math> = angle of twist</p> <p>= resistance factor for LRFD</p> <p>= diameter symbol</p> <p><math>\mu</math> = lateral strain ratio or Poisson's ratio</p> <p><math>\gamma</math> = shear strain</p> <p>= density or unit weight</p> <p><math>\gamma_D</math> = dead load factor for LRFD</p> <p><math>\gamma_L</math> = live load factor for LRFD</p> <p><math>\theta</math> = angle of principle stress</p> <p><math>\rho</math> = radial distance</p> <p><math>\sigma</math> = engineering symbol for normal stress</p> <p><math>\tau</math> = engineering symbol for shearing stress</p>
---	--

### Normal Strain

In an axially loaded member, normal strain,  $\varepsilon$  is the change in the length,  $\delta$  with respect to the original length,  $L$ .

$$\varepsilon = \frac{\delta}{L}$$

It is UNITLESS, but may be called strain or microstrain ( $\mu$ ).

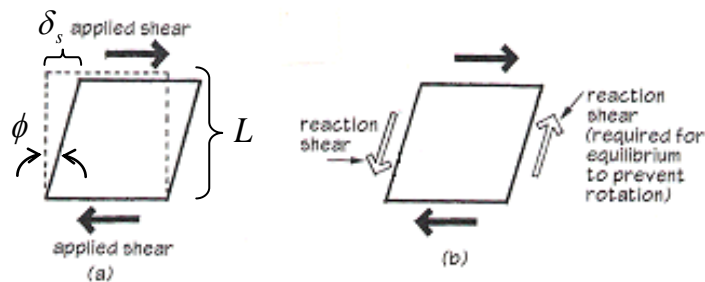
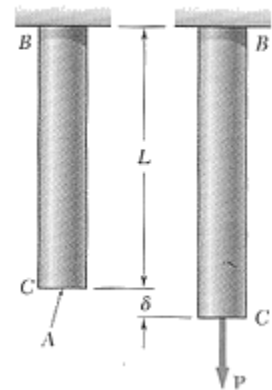

### Shearing Strain

In a member loaded with shear forces, shear strain,  $\gamma$  is the change in the sheared side,  $\delta_s$  with respect to the original height,  $L$ . For small angles:  $\tan \phi \cong \phi$ .

$$\gamma = \frac{\delta_s}{L} = \tan \phi \cong \phi$$

In a member subjected to twisting, the shearing strain is a measure of the angle of twist with respect to the length and distance from the center,  $\rho$ :

$$\gamma = \frac{\rho\phi}{L}$$

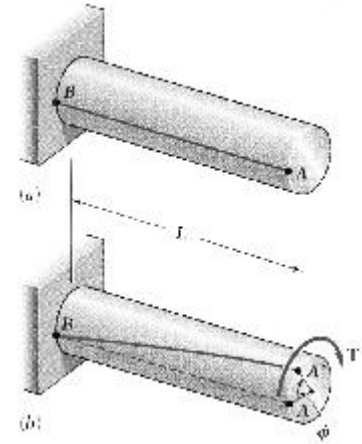

**Testing of Load vs. Strain**

Behavior of materials can be measured by recording deformation with respect to the size of the load. For members with constant cross section area, we can plot stress vs. strain.

BRITTLE MATERIALS - ceramics, glass, stone, cast iron; show abrupt fracture at small strains.

DUCTILE MATERIALS - plastics, steel; show a yield point and large strains (considered *plastic*) and “necking” (give warning of failure)

SEMI-BRITTLE MATERIALS - concrete; show no real yield point, small strains, but have some “strain-hardening”.

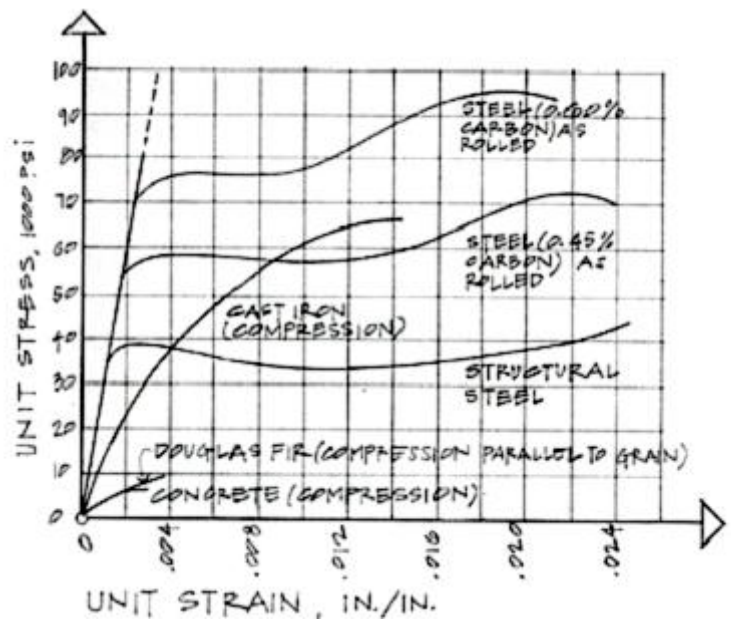

Linear-Elastic Behavior

In the straight portion of the stress-strain diagram, the materials are *elastic*, which means if they are loaded and unloaded no permanent **deformation** occurs.

**True Stress & Engineering Stress**

True stress takes into account that the area of the cross section changes with loading.

Engineering stress uses the original area of the cross section.

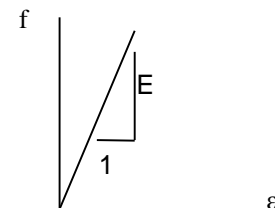

## Hooke's Law – Modulus of Elasticity

In the linear-elastic range, the slope of the stress-strain diagram is *constant*, and has a value of  $E$ , called Modulus of Elasticity or Young's Modulus.

$$f = E \cdot \varepsilon$$

Isotropic Materials – have the **same**  $E$  with any direction of loading.

Anisotropic Materials – have **different**  $E$ 's with the direction of loading.

Orthotropic Materials – have **directionally based**  $E$ 's

**Table D-1** Elastic moduli of selected materials

Material	Modulus of elasticity $E$		Shear modulus $G$		Poisson's ratio $\nu$
	$10^6$ psi	GPa	$10^6$ psi	GPa	
Aluminum	10	70	3.8	26	0.33
Aluminum alloys	10–12	70–80	3.8–4.4	26–30	0.33
2014-T6	10.6	73	4	28	0.33
6061-T6	10	70	3.8	26	0.33
7075-T6	10.4	72	3.9	27	0.33
Brick (compression)	1.5–3.5	10–24			
Cast iron	12–25	80–170	4.5–10	31–69	0.2–0.3
Gray cast iron	14	97	5.6	39	0.25
Concrete (compression)	2.6–4.4	18–30			0.1–0.2
Copper	17	115	6.2	43	0.35
Copper alloys	14–18	96–120	5.2–6.8	36–47	0.33–0.35
Brass	14–16	96–110	5.2–6	36–41	0.34
80% Cu, 20% Zn	15	100	5.5	38	0.33
Naval brass	15	100	5.5	38	0.33
Bronze	14–17	96–120	5.2–6.3	36–44	0.34
Manganese bronze	15	100	5.6	39	0.35
Glass	7–12	50–80	2.9–5	20–33	0.20–0.27
Magnesium	5.8	40	2.2	15	0.34
Nickel	30	210	11.4	80	0.31
Nylon	0.3–0.4	2–3			0.4
Rubber	0.0001–0.0006	0.001–0.004	0.00004–0.0002	0.0003–0.0014	0.44–0.50
Steel	28–32	190–220	10.8–12.3	75–85	0.28–0.30
Stone (compression)					
Granite	6–10	40–70			0.2–0.3
Marble	7–14	50–100			0.2–0.3
Titanium	16	110	5.8	40	0.33
Titanium alloys	15–18	100–124	5.6–6.8	39–47	0.33
Tungsten	52	360	22	150	0.2
Wood (bending)					
Ash	1.5–1.6	10–11			
Oak	1.6–1.8	11–12			
Southern pine	1.6–2	11–14			
Wrought iron	28	190	10.9	75	0.3

## Plastic Behavior & Fatigue

Permanent deformations happen outside the linear-elastic range and are called *plastic* deformations. Fatigue is damage caused by reversal of loading.

- The proportional limit (at the end of the **elastic** range) is the greatest stress valid using Hooke's law.
- The elastic limit is the maximum stress that can be applied before permanent deformation would appear upon unloading.
- The yield point (at the *yield stress*) is where a ductile material continues to elongate without an increase of load. (May not be well defined on the stress-strain plot.)
- The ultimate strength is the largest stress a material will see before rupturing, also called the *tensile strength*.
- The rupture strength is the stress at the point of rupture or failure. It may not coincide with the ultimate strength in ductile materials. In brittle materials, it will be the same as the ultimate strength.
- The fatigue strength is the stress at failure when a member is subjected to reverse cycles of stress (up & down or compression & tension). This can happen at much lower values than the ultimate strength of a material.
- Toughness of a material is how much work (a combination of stress and strain) is used for fracture. It is the area under the stress-strain curve.

Concrete does not respond well to tension and is tested in compression. The strength at crushing is called the *compression strength*.

Materials that have time dependent elongations when loaded are said to have *creep*. Concrete and wood creep. Concrete also has the property of shrinking over time.

**Poisson's Ratio**

For an isotropic material that is homogeneous, the properties are the same for the cross section:

$$\epsilon_y = \epsilon_z$$

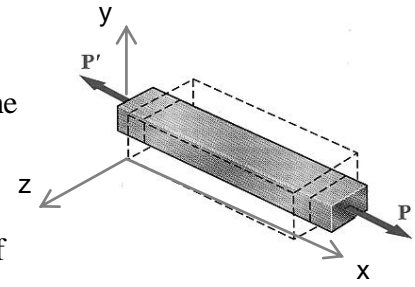

There exists a linear relationship while in the linear-elastic range of the material between *longitudinal strain* and *lateral strain*:

$$\mu = -\frac{\text{lateral strain}}{\text{axial strain}} = -\frac{\epsilon_y}{\epsilon_x} = -\frac{\epsilon_z}{\epsilon_x} \quad \epsilon_y = \epsilon_z = -\frac{\mu f_x}{E}$$

Positive strain results from an increase in length with respect to overall length.

Negative strain results from a decrease in length with respect to overall length.

$\mu$  is the Poisson's ratio and has a value between 0 and 1/2, depending on the material

**Relation of Stress to Strain**

$$f = \frac{P}{A}; \quad \epsilon = \frac{\delta}{L} \quad \text{and} \quad E = \frac{f}{\epsilon} \quad \text{so} \quad E = \frac{P/A}{\delta/L} \quad \text{which rearranges to:} \quad \delta = \frac{PL}{AE}$$

**Orthotropic Materials**

One class of non-isotropic materials is *orthotropic materials* that have directionally based values of modulus of elasticity and Poisson's ratio ( $E, \mu$ ).

Ex: plywood, laminates, fiber reinforced polymers with direction fibers

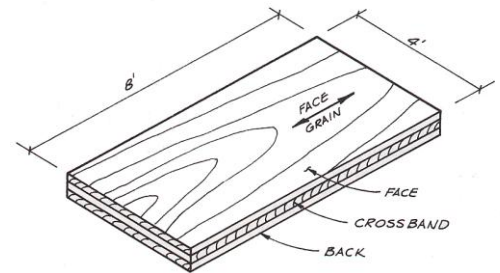

**Stress Concentrations**

In some sudden changes of cross section, the stress concentration changes (and is why we used *average* normal stress). Examples are sharp notches, or holes or corners.

(Think about airplane window shapes...)

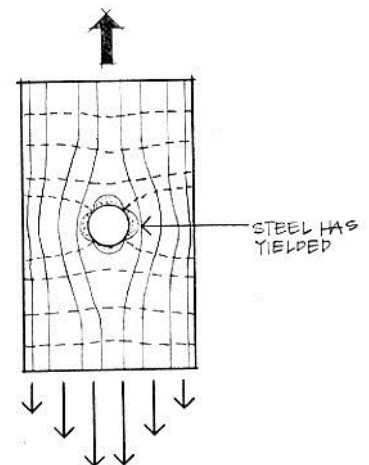

## Maximum Stress

When both normal stress and shear stress occur in a structural member, the *maximum stresses can occur at some other planes* (angle of  $\theta$ ).

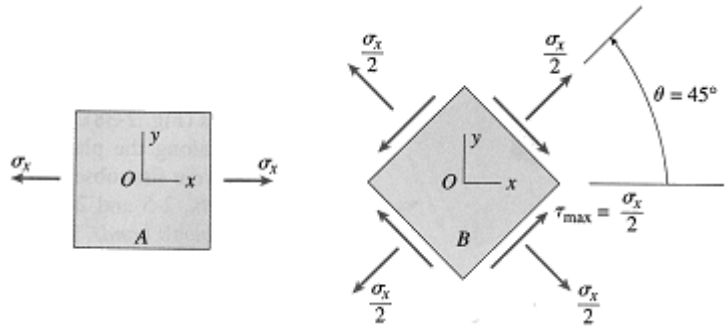

Maximum Normal Stress happens at  $\theta = 0^\circ$  AND

Maximum Shearing Stress happens at  $\theta = 45^\circ$  with only normal stress in the  $x$  direction.

## Allowable Stress Design (ASD) and Factor of Safety (F.S.)

There are uncertainties in material strengths:

$$F.S. = \frac{\text{ultimate load}}{\text{allowable load}} = \frac{\text{ultimate stress}}{\text{allowable stress}}$$

Allowable stress design determines the allowable stress by:  $\text{allowable stress} = \frac{\text{ultimate stress}}{F.S.}$

## Load and Resistance Factor Design – LRFD

There are uncertainties in material strengths *and* in structural loadings.

$$\gamma_D R_D + \gamma_L R_L \leq \phi R_n$$

where  $\gamma$  = load factor for Dead and Live loads  
 $R$  = load (dead or live)  
 $\phi$  = resistance factor  
 $R_n$  = nominal load (capacity)