

Mechanics of Materials

Notation:

<p>A = area (net = with holes, bearing = in contact, etc...)</p> <p>d = diameter of a hole</p> <p>f = symbol for stress</p> <p>$f_{allowable}$ = allowable stress</p> <p>f_v = shear stress</p> <p>f_p = bearing stress (see P)</p> <p>$F_{allowed}$ = allowable stress (used by codes)</p> <p>F_v = allowable shear stress</p> <p>kPa = kilopascals or 1 kN/m^2</p> <p>q = allowable soil bearing pressure</p> <p>psi = pounds per square inch</p>	<p>P = name for axial force vector</p> <p>P' = name for internal axial force vector</p> <p>R = name for reaction force vector</p> <p>t = thickness of a hole or member</p> <p>x = horizontal dimension</p> <p>y = vertical dimension</p> <p>γ = density of a material (unit weight)</p> <p>σ = engineering symbol for normal stress</p> <p>τ = engineering symbol for shearing stress</p>
---	---

Mechanics of Materials is a basic engineering science that deals with the relation between externally applied load and its effect on deformable bodies. The main purpose of Mechanics of Materials is to answer the question of which requirements have to be met to assure **STRENGTH, RIGIDITY, AND STABILITY** of engineering structures.

To solve a problem in Mechanics of Materials, one has to consider **THREE ASPECTS OF THE PROBLEM**:

1. **STATICS**: equilibrium of external forces, internal forces, stresses
2. **GEOMETRY**: deformations and conditions of geometric fit, strains
3. **MATERIAL PROPERTIES**: stress-strain relationship for each material, obtained from material testing.

- **STRESS** – The intensity of a force acting over an **area**.

Normal Stress

Stress that acts along an *axis* of a member; can be internal or external; can be compressive or tensile.

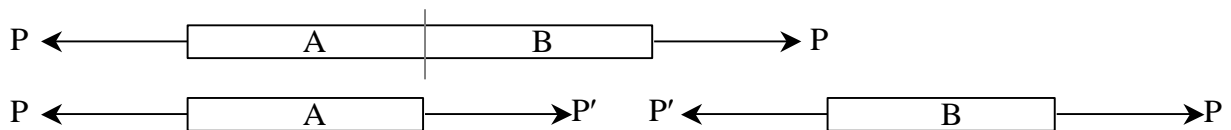

$$f = \sigma = \frac{P}{A_{net}} \quad \text{Strength condition: } f = \frac{P}{A_{net}} < f_{allowable} \text{ or } F_{allowed}$$

Shear Stress

Stress that acts perpendicular to an *axis or length* of a member, or **parallel** to the cross section is called shear stress.

Shear stress cannot be assumed to be uniform, so we refer to *average shearing stress*.

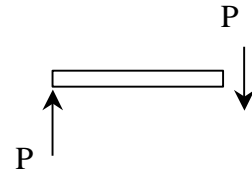

$$f_v = \tau = \frac{P}{A_{net}}$$

Strength condition: $f_v = \frac{P}{A_{net}} < \tau_{allowable} \text{ or } F_{allowed}$

Bearing Stress

A compressive normal stress acting *between two bodies*.

$$f_p = \frac{P}{A_{bearing}}$$

Bending Stress

A normal stress caused by bending; can be compressive or tensile. (Discussed in Note Set on Beam Bending.)

Torsional Stress

A shear stress caused by torsion (moment around the axis). (Discussed in Note Set on Torsion.)

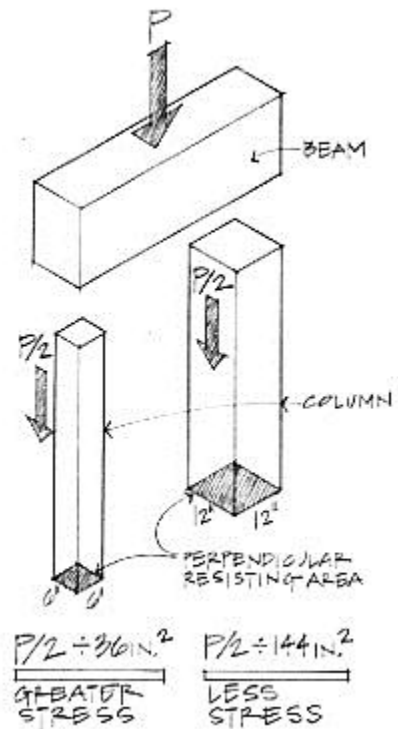

Bolts in Shear and Bearing

Single shear - forces cause only one shear “drop” across the bolt.

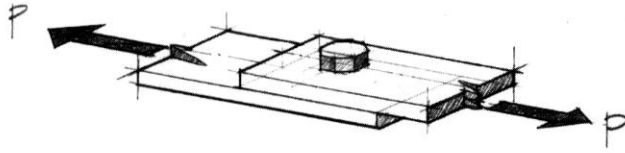

(a) Two steel plates bolted using one bolt.

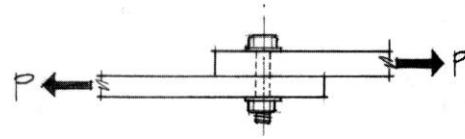

(b) Elevation showing the bolt in shear.

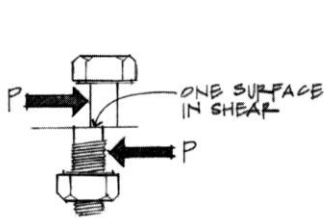

(c)

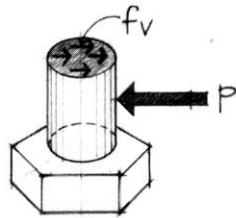

(d)

f_v = Average shear stress through bolt cross section

A = Bolt cross-sectional area

$$f_v = \frac{P}{A}$$

Figure 5.11 A bolted connection—single shear.

Double shear - forces cause two shear changes across the bolt.

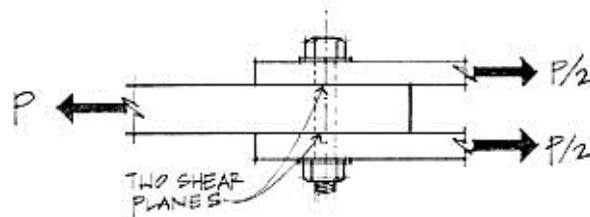

$$f_v = \frac{P}{2A}$$

(two shear planes)

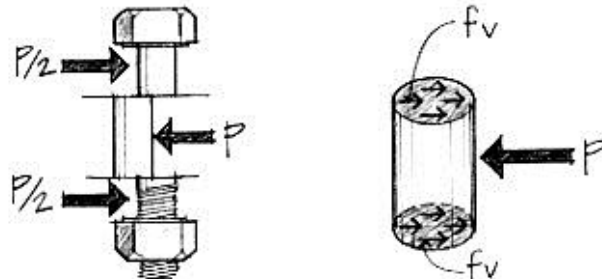

Free-body diagram of middle section of the bolt in shear.

Figure 5.12 A bolted connection in double shear.

Bearing of a bolt on a bolt hole – The bearing surface can be represented by *projecting* the cross section of the bolt hole on a plane (into a rectangle).

$$f_p = \frac{P}{A} = \frac{P}{td}$$

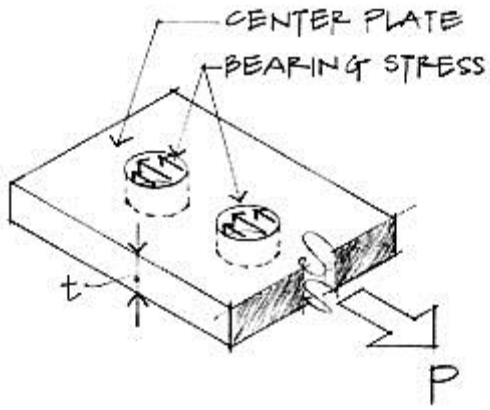

Bearing stress on plate.

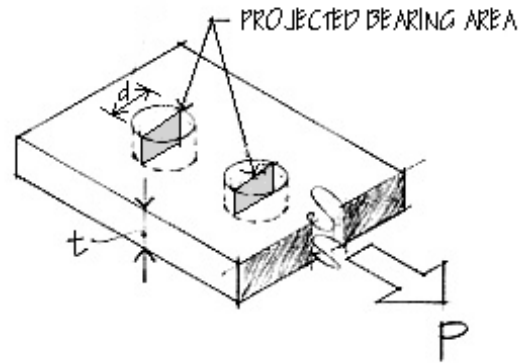

Example 1 (pg 201)*

Example Problem 6.8 (Figures 6.18 to 6.20)

A pipe storage rack is used for storing pipe in a shop. The support rack beam is fastened to the main floor beam using steel straps $\frac{1}{2}'' \times 2''$ in dimension. Round bolts are used to fasten the strap to the floor beam in single shear. (a) If the weight of the pipes impose a maximum tension load of 10,000 pounds in each strap, determine the tension stress developed in the steel strap. (b) Also, what diameter bolt is necessary to fasten the strap to the floor beam if the allowable shear stress for the bolts equals $F_v = 15,000 \text{ lb./in.}^2$? Determine the bearing stress in the strap from the bolt diameter chosen. If the straps are 10 ft. in length, how much elongation would occur? What is the ultimate load capacity in each strap? Assume A36 steel: $F_u = 58 \text{ ksi}$, $E = 29 \times 10^3 \text{ ksi}$.

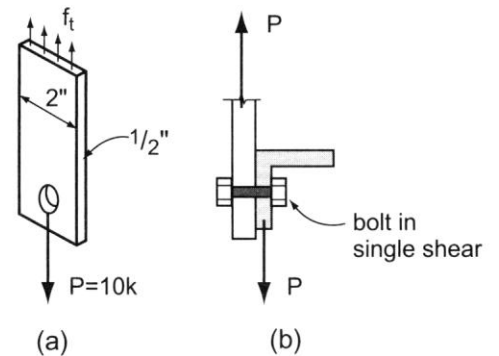
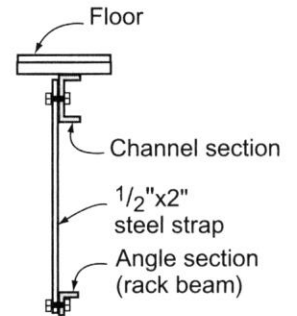
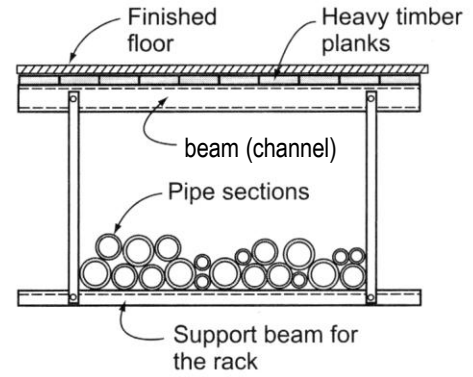

Example 2 (pg 202)**Example Problem 6.9 (Figures 6.21 to 6.26)**

A 75 mm × 200 mm “rough cut” beam is supported by columns at both ends. Column *AB* supports the beam in bearing while column *CD* utilizes a shear block at *C*. Both columns bear on concrete footings on the ground.

- What is the compressive stress developed in column *AB*? $R_A = 24 \text{ kN}$
- What is the bearing stress that develops at *C* between the beam and shear block made from a 100 mm × 100 mm block cut from a post?
- What is the required depth y necessary to resist the shear force developed at the glued joint between the shear block and post? Assume that the glue is capable of safely resisting 500 kPa (72.5 psi) in shear.
- Determine the size of square footing required to take the maximum column load if the allowable soil pressure $q = 73 \text{ kN/m}^2 = 73 \text{ kPa}$ (1525 psf).

