

## Forces and Vectors

### Notation:

$F$ = name for force vectors, as is $A$ , $B$ , $C$ , $T$ and $P$ $F_x$ = force component in the x direction $F_y$ = force component in the y direction $R$ = name for resultant vectors $R_x$ = resultant component in the x direction $R_y$ = resultant component in the y direction	$tail$ = start of a vector (without arrowhead) $tip$ = direction end of a vector (with arrowhead) $x$ = x axis direction $y$ = y axis direction $\theta$ = angle, in a trig equation, ex. $\sin\theta$ , that is measured between the x axis and $tail$ of a vector
---	---

### Characteristics

- Forces have *a point of application* – tail of vector  
*size* – units of lb, K, N, kN  
*direction* – to a reference system, sense indicated by an arrow
- Classifications include: *Static & Dynamic*
- Structural types separated primarily into *Dead Load* and *Live Load* with further identification as wind, earthquake (seismic), impact, etc.

### Rigid Body

- *Ideal* material that doesn't deform
- Forces on rigid bodies can be *internal* – within or at connections  
 or *external* – applied
- Rigid bodies can *translate* (move in a straight line)  
 or *rotate* (change angle)

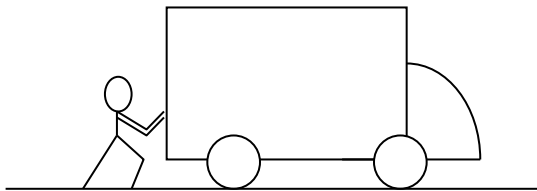

- Weight of truck is external (gravity)
- Push by driver is external
- Reaction of the ground on wheels is external

If the truck moves forward: *it translates*

If the truck gets put up on a jack: *it rotates*

- *Transmissibility*: We can replace a force at a point on a body by that force on another point on the body along the line of action of the force.

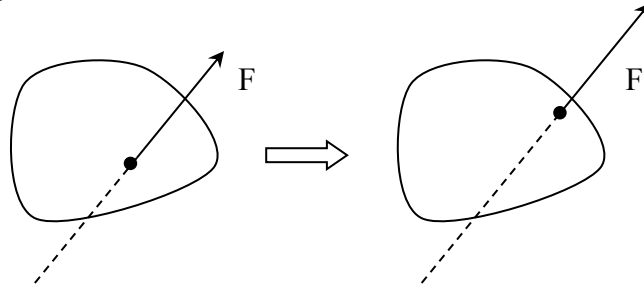

External conditions haven't changed

For the truck:

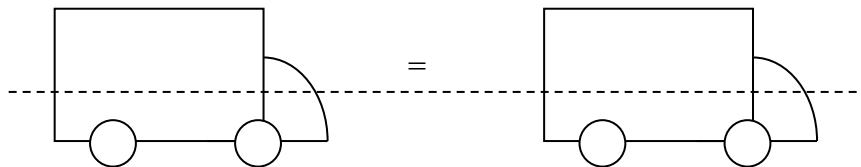

- The same external forces will result in the same conditions for motion
- Transmissibility applies to EXTERNAL forces. INTERNAL forces respond differently when an external force is moved.
- DEFINITION: *2D Structure* - A structure that is flat and may contain a plane of symmetry. All forces on this structure are in the same plane as the structure.

**Internal and External**

- *Internal forces* occur within a member or between bodies within a system
- *External forces* represent the action of other bodies or gravity on the rigid body

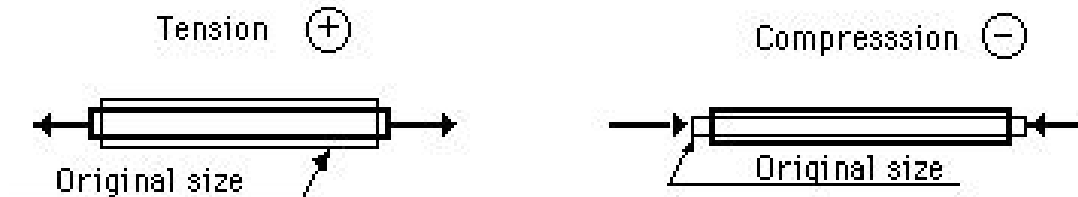

## Force System Types

- *Collinear* – all forces along the same **line**
- *Coplanar* – all forces in the same **plane**
- *Space* – out there

Further classification as

- *Concurrent* – all forces go through the same **point**
- *Parallel* – all forces are **parallel**

## Graphical Addition

- *Parallelogram law*: when adding two vectors acting at a point, the result is the **diagonal** of the parallelogram
- The *tip-to-tail* method is another graphical way to add vectors.

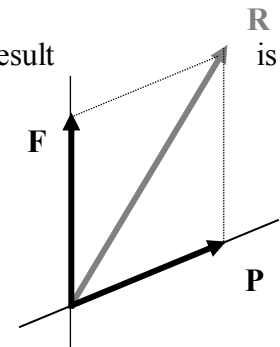
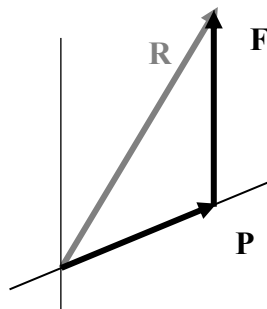

- With **3 (three)** or more vectors, successive application of the parallelogram law will find the resultant *OR* drawing all the vectors **tip-to-tail** in any order will find the resultant.

## Rectangular Force Components and Addition

- It is convenient to resolve forces into perpendicular components (at  $90^\circ$ ).
- Parallelogram law results in a rectangle.
- Triangle rule results in a right triangle.

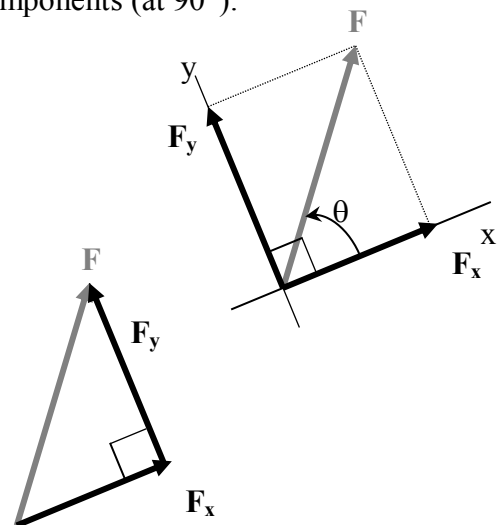
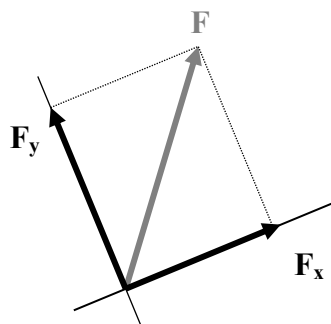

$\theta$  is: *between x & F*

$$F_x = F \cdot \cos\theta$$

$$F_y = F \cdot \sin\theta$$

$$F = \sqrt{F_x^2 + F_y^2}$$

$$\tan\theta = \frac{F_y}{F_x}$$

} magnitudes are *scalar* and can be negative  
 $F_x$  &  $F_y$  are *vectors* in x and y direction

When  $90^\circ < \theta < 270^\circ$ ,  $F_x$  is *negative*

When  $180^\circ < \theta < 360^\circ$ ,  $F_y$  is *negative*

When  $0^\circ < \theta < 90^\circ$  and  $180^\circ < \theta < 270^\circ$ ,  $\tan\theta$  is *positive*

When  $90^\circ < \theta < 180^\circ$  and  $270^\circ < \theta < 360^\circ$ ,  $\tan\theta$  is *negative*

- Addition (analytically) can be done by adding all the x components for a **resultant x** component and adding all the y components for a resultant y component.

$$R_x = \sum F_x, \quad R_y = \sum F_y \quad \text{and} \quad R = \sqrt{R_x^2 + R_y^2} \quad \tan\theta = \frac{R_y}{R_x}$$

**CAUTION:** An interior angle,  $\phi$ , between a vector and *either* coordinate axis can be used in the trig functions. BUT No sign will be provided by the trig function, which means **you** must give a sign and determine if the component is in the x or y direction.

*For example,  $F \sin\phi = \text{opposite side}$ , which would be negative in x!*

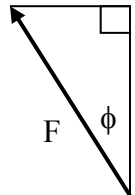

Example 1 (page 9)**Example Problem 2.2**

A utility pole supports two tension forces  $A$  and  $B$  with the directions shown. Using the parallelogram law and the tip-to-tail methods, determine the resultant force for  $A$  and  $B$  (magnitude and direction).

Scale: 1" = 200 lb.

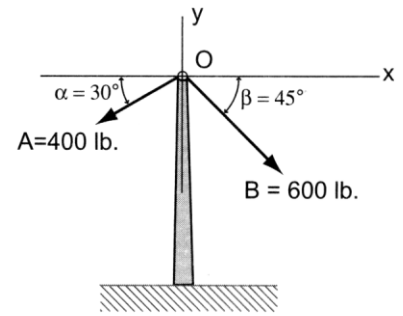
**Steps:**

1. **GIVEN:** Write down what's given (drawing and numbers).
2. **FIND:** Write down what you need to find. (resultant graphically)
3. **SOLUTION:**
4. Draw the 400 lb and 600 lb forces to scale with tails at  $O$ . (If the scale isn't given, you must choose one that fits on your paper, ie. 1 inch = 200 lb.)
5. Draw parallel reference lines at the ends of the vectors.
6. Draw a line from  $O$  to the intersection of the reference lines
7. Measure the length of the line
8. Convert the line length by the scale into pounds (by multiplying by the force measure and dividing by the scale value, ie  $X$  inches \* 200 lb / 1 inch).
9. Measure the angle with respect to the positive  $x$  axis.

**Alternate solution:**

4. Draw one vector
5. Draw the other vector at the TIP of the first one (away from the tip).
6. Draw a line from 0 to the tip of the final vector and continue at step 7

Example 2 (pg 12)

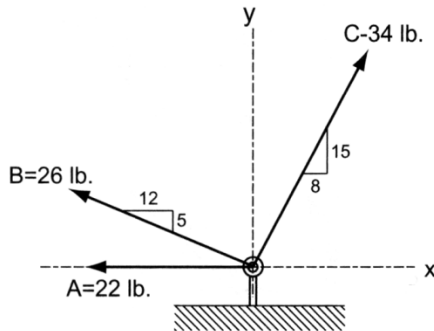

**Example Problem 2.4**

A tent stake is subjected to three pulling forces, as shown in Figure 2.18. Using the graphical tip-to-tail method, determine the resultant of forces *A*, *B*, and *C* (magnitude and direction).

1.5 mm = 1 lb. or 1mm = 2/3 lb.  
 Suggested scale: 1/8" = 1 lb. or 1" = 8 lb.

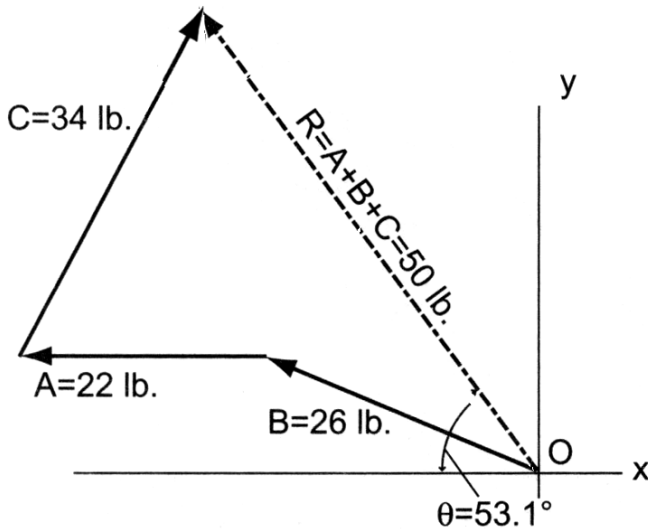
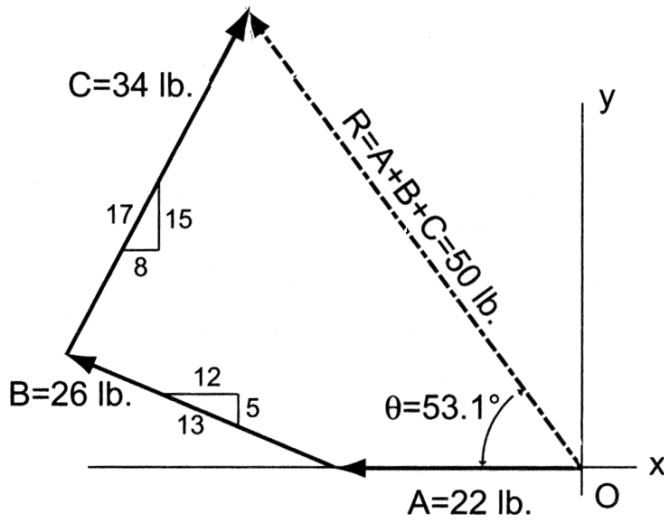

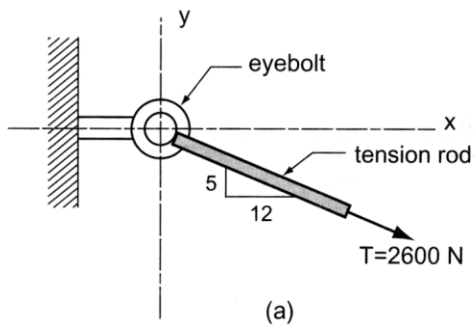
Example 3 (pg 16)**Example Problem 2.7**

A large eyebolt (Figure 2.24) is used in supporting a canopy over the entry to an office building. The tension developed in the support rod is equal to 2600 newtons. Determine the rectangular components of the force if the rod is at a 5 in 12 slope.

Also determine the embedment length,  $L$ , if the anchor can resist 500 N for every cm of embedment.

Example 4 (pg 19) Determine the resultant vector analytically with the component method.

**Example Problem 2.9 (Figure 2.29)**

This is the same problem as Example Problem 2.2, which was solved earlier using the graphical methods.

