

System Assemblies & Load Tracing

Notation:

<p>a = name for a dimension</p> <p>C = symbol for compression</p> <p>DL = shorthand for dead load</p> <p>$F_{horizontal-resisting}$ = total force resisting horizontal sliding</p> <p>$F_{sliding}$ = total sliding force</p> <p>F_y = force component in the y direction</p> <p>FBD = free body diagram</p> <p>h = name for height</p> <p>L = name for length</p> <p>LL = shorthand for live load</p> <p>M = moment due to a force</p> <p>$M_{overturning}$ = total overturning moment</p> <p>$M_{resisting}$ = total moment resisting overturning about a point</p> <p>N = name for normal force to a surface</p> <p>$o.c.$ = shorthand for on center</p> <p>p = pressure</p> <p>P = force due to a pressure</p> <p>SF = shorthand for factor of safety</p> <p>R = name for reaction force</p>	<p>T = symbol for tension</p> <p>= name of a tension force</p> <p>v = distributed shear</p> <p>V = name for shear (horizontal) force</p> <p>w = name for distributed load/length, as is ω</p> <p>= name for distributed load/area</p> <p>$w_{self\ wt}$ = name for distributed load from self weight of member</p> <p>$w_{self\ wt\ equiv}$ = name for equivalent distributed vertical load from self weight of slanted member</p> <p>W = name for total force due to distributed load</p> <p>= force due to a weight</p> <p>x = horizontal distance</p> <p>μ = coefficient of static friction</p> <p>γ = density or unit weight</p> <p>ω' = equivalent fluid density of a soil</p> <p>Σ = summation symbol</p>
---	--

Load Tracing

- LOAD TRACING is the term used to describe how the loads on and in the structure are transferred through the members (*load paths*) to the foundation, and ultimately supported by the ground.
- It is a sequence of **actions**, NOT reactions. Reactions in statically determinate members (using FBD's) can be solved for to determine the actions on the next member in the hierarchy.
- The *tributary area* is a loaded area that contributes to the load on the member supporting that area, *ex.* the area from the center between two beams to the center of the next two beams for the full span is the load on the center beam
- The *tributary load* on the member is found by **concentrating (or consolidating)** the load into the center.

$$w = \left(\frac{\text{load}}{\text{area}} \right) \times (\text{tributary width})$$

where w = distributed load in units of load/length.

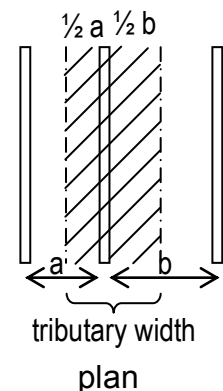
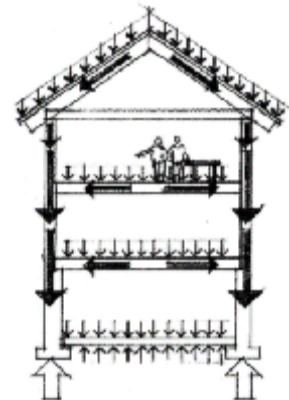

Distributed Loads

Distributed loads may be replaced by concentrated loads acting through the balance/center of the distribution or *load area*: THIS IS AN **EQUIVALENT** FORCE SYSTEM.

- w is the symbol used to describe the *load per unit length*.
Note: It can also represent a load per unit area.
- W is the symbol used to describe the *total load*.

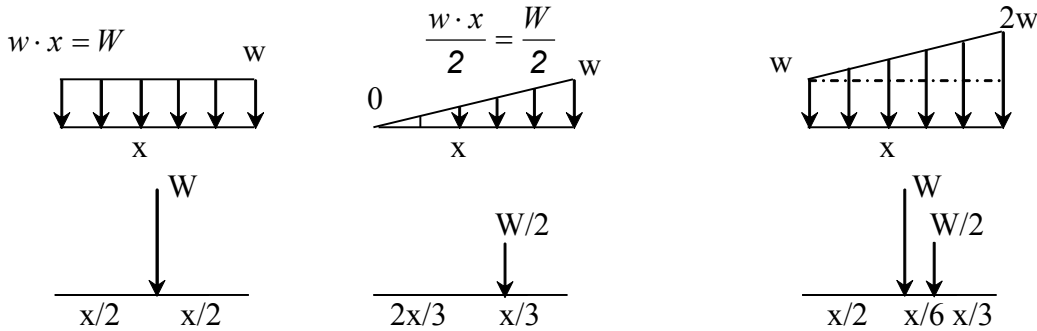

Framing Systems

Horizontal levels must transfer loads to vertical elements. There are many ways to configure the systems. The horizontal levels can be classified by how many elements transfer loads in the plane. Decking is not usually considered a level in a multiple level system because it isn't significantly load-bearing. It is considered a level when it is the only horizontal element and must resist loads.

Foundations

The final path of the load for the structure is to the foundation. The foundation must transfer the loads to the soil, which is a "natural" structural material. The soil conditions will determine if a shallow foundation (most economical and easy to construct) can be used, or a deep foundation (for larger loads or poorer soil capacities) must be considered.

Distribution of Loads with Irregular Configurations

When a bay (defined by the area bounded by vertical supports) is not rectangular, it is commonly constructed with parallel or non-parallel spanning members of non-uniform lengths. With parallel spanning members, the tributary width is uniform. With non-parallel members, the tributary width at each end is different, but still defined as half the distance (each side) to the next member. The resulting distribution will be linear (and not uniform).

The most efficient one-way systems have regular, rectangular bays. Two way systems are most efficient when they are square. With irregular bays, attempts are made to get as many parallel members as possible with similar lengths, resulting in an economy of scale.

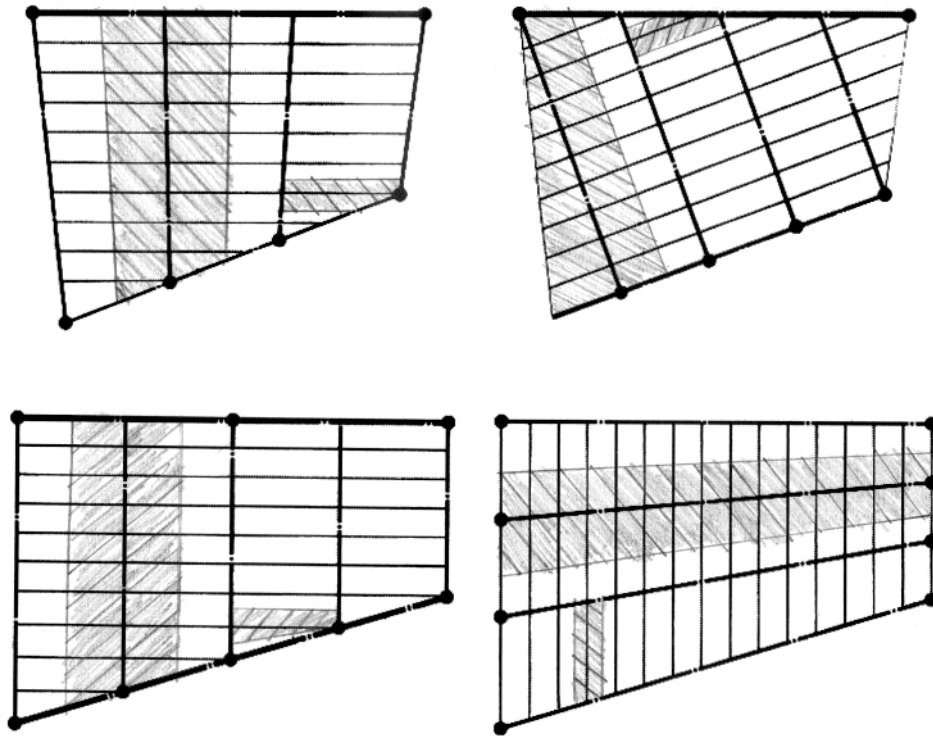

Distribution of Loads on Edge Supported Slabs

Distributed loads on two-way slabs (i.e. not one-way like beams) do not have obvious tributary “widths”. The distribution is modeled using a 45 degree tributary “boundary” in addition to the tributary boundary that is half way between supporting elements, in this case, edge beams.

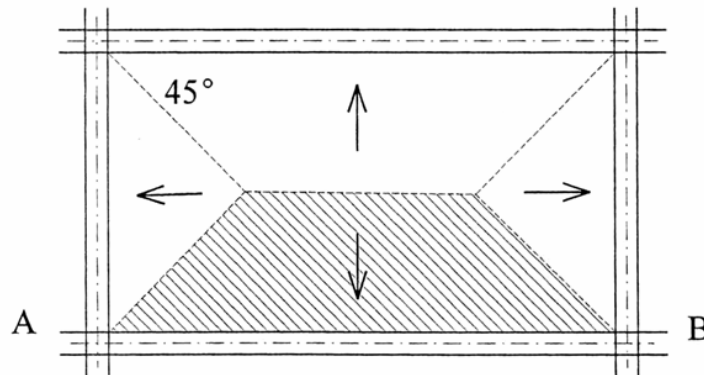

Figure 2-16: Supporting beams' contributing areas for reinforced concrete floor system.

The tributary distribution *from the area loads* result in a trapezoidal distribution. Self weight will be a uniform distributed load, and will also have to be included for design of beam AB.

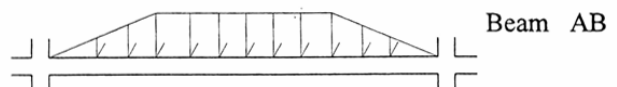

Figure 2-17: Trapezoidal distributed load for Beam AB of Fig. 2-16.

Openings in Floor/Roof Plans

Openings in a horizontal system usually are framed on all sides. This provides for stiffness and limiting the deflection. The edge beams may not be supporting the flooring, however, so care needs to be taken to determine if an opening edge beam must support tributary area, or just itself.

- Any edge beam supporting a load has load on only one side to the next supporting element.

Beams Supported by Other Beams

Joists are commonly supported by beams with beam hangers. The reaction at the support is transferred to the beam as a single force. A beam, in turn, can be supported by a larger beam or girder, and the reaction from this beam having a uniform distributed self weight, and the forces, will be an action on the girder.

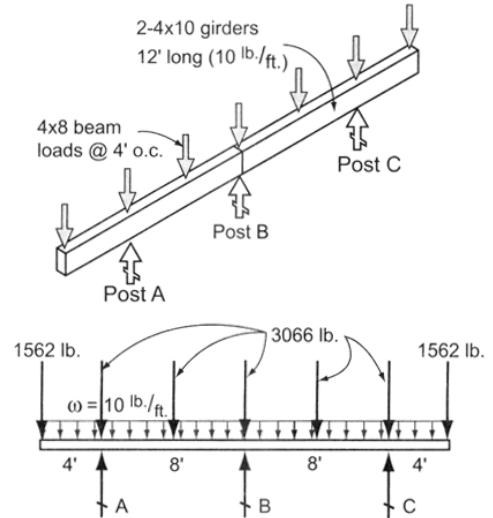

Horizontal Projection of Gravity Load on a Rafter

When an angled member, such as a rafter has a self weight per unit length, that weight is usually converted to a weight per horizontal length:

$$W_{self\ wt.\ equiv.} = W_{self\ wt.} \left(\frac{\text{length}}{\text{horizontal distance}} \right) \text{ or } W_{self\ wt.} / \cos \alpha$$

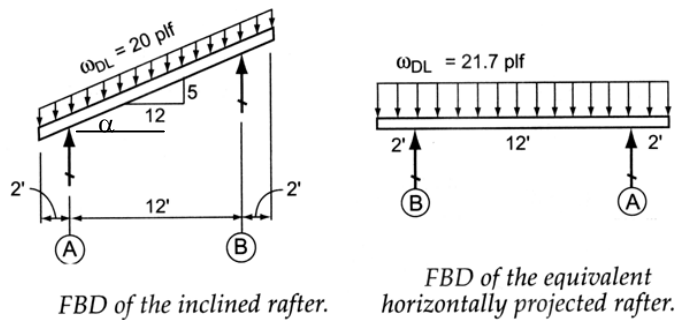

Framing Plans

Framing plans are diagrams representing the placement and organization of structural members. Until the final architecture has been determined, framing plans are often drawn freehand with respect to the floor plans, and quite often use the formal conventions for structural construction drawings.

Parts of the building are identified by letter symbols:

- | | | | |
|--------------------|---------------------|--------------------|---------------------|
| <i>B</i> – Beams | <i>F</i> – Footings | <i>L</i> – Lintels | <i>U</i> – Stirrups |
| <i>C</i> – Columns | <i>G</i> – Girders | <i>S</i> – Slabs | <i>W</i> – Walls |
| <i>D</i> – Dowels | <i>J</i> – Joists | <i>T</i> – Ties | |

Other parts are represented with lines (beams and joists), dots, squares, rectangles or wide-flange shapes for columns. Column and footing locations in structural drawings are referred to by letters and numbers, with vertical lines at column centers given letters – *A, B, C*, etc., and horizontal lines at columns given numbers – *1, 2, 3*, etc. The designation *do* may be used to show like members (like *ditto*).

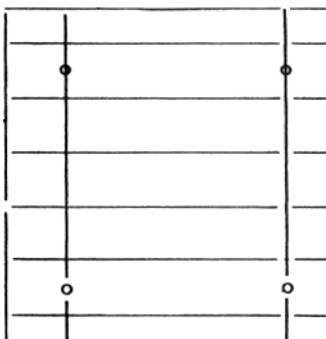
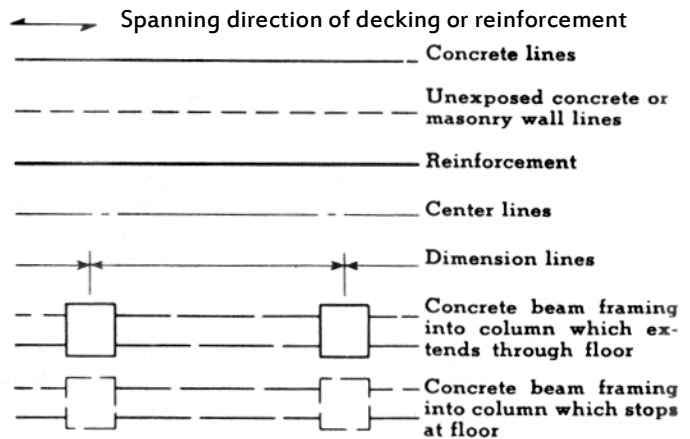
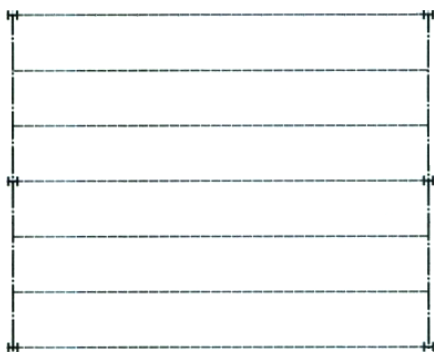
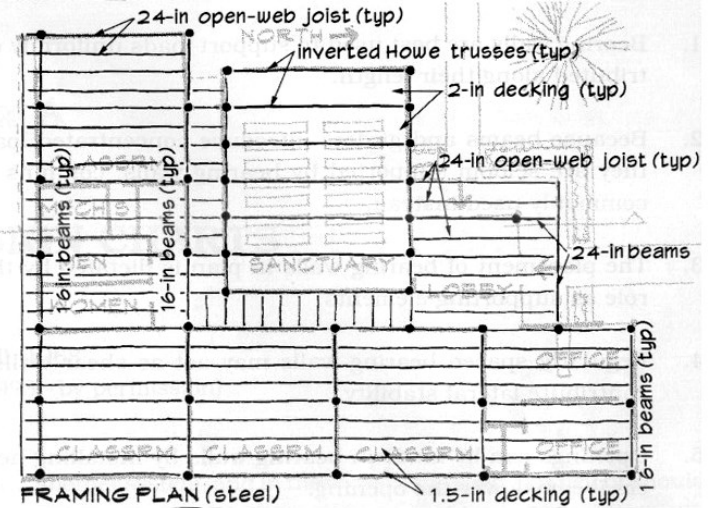
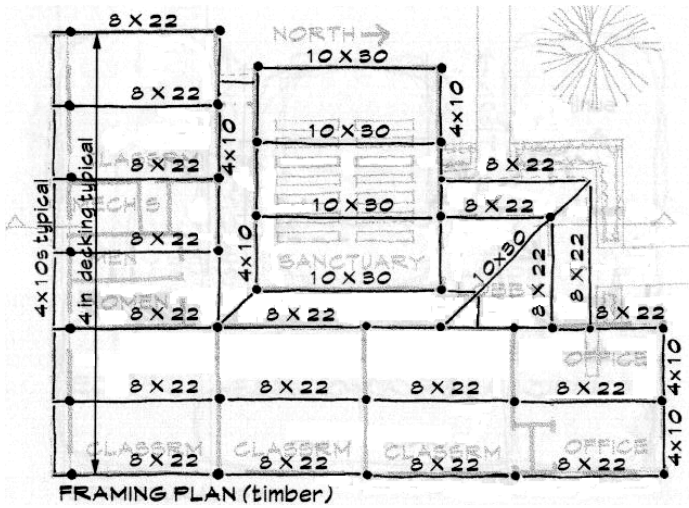

Breaks in the lines are commonly used to indicate the *end* of a beam that is supported by another member, such as a girder or column. Beams can span over a support (as a continuous beam) and therefore, there is no break shown at the column.

Joists can span over a supporting beam, and the lines will cross. (Looking for the ends of the crossing members give information about which is below and which is above.)

Concrete systems often have slabs, ribs or drop panels or strips, which aren't easily represented by centerlines, so hidden lines represent the edges. Commonly isolated "patches" of repeated geometry are used for brevity.

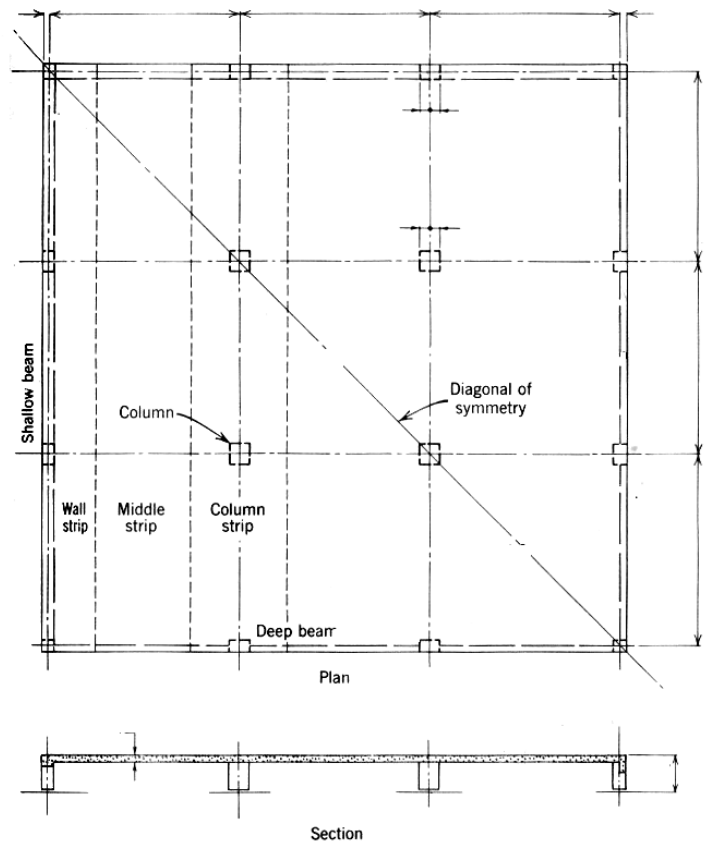
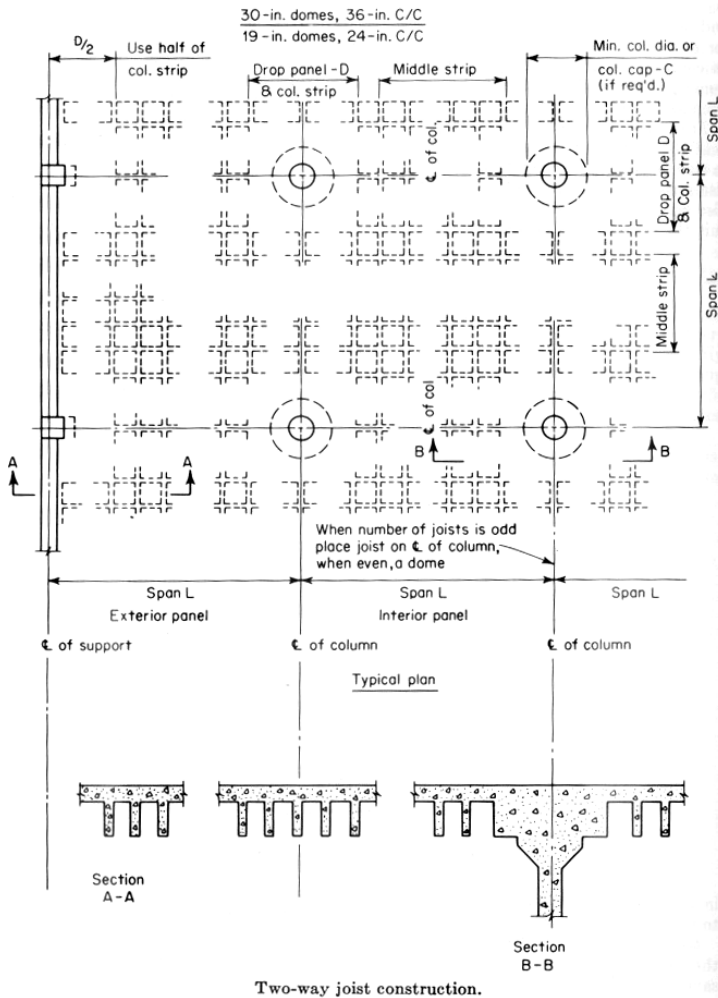
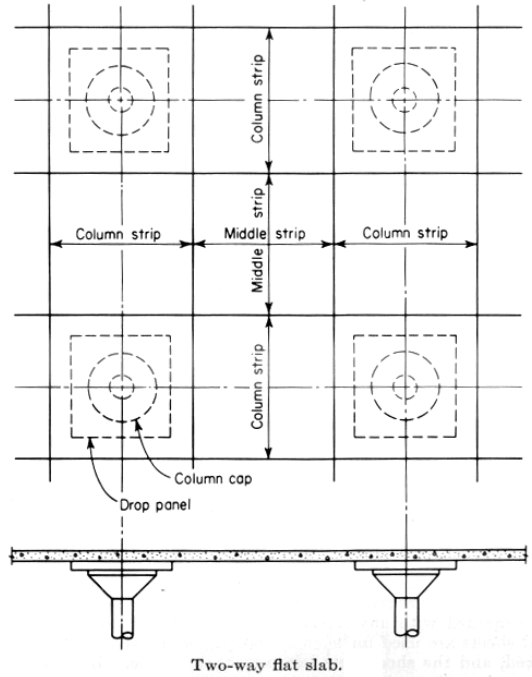
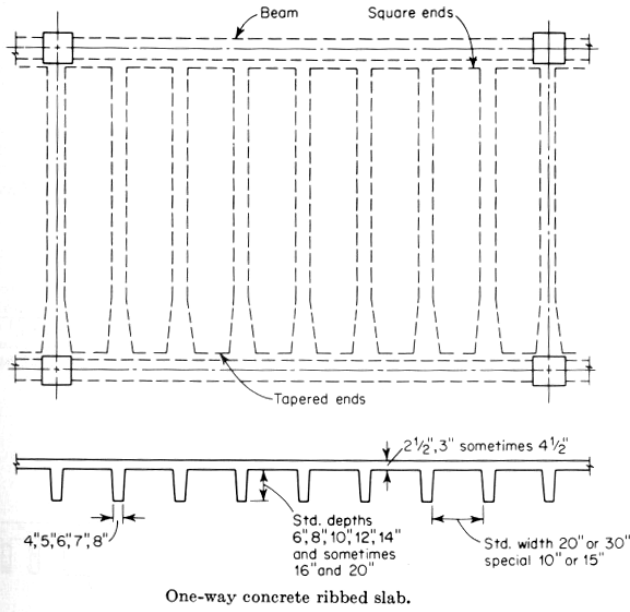

Retaining Walls

Retaining walls are used to hold back soil or other material with the wall. The other key components include bases, counterforts, buttresses or keys. Gravity loads help provide resistance to movement, while the walls with lateral loads behave like cantilever beams.

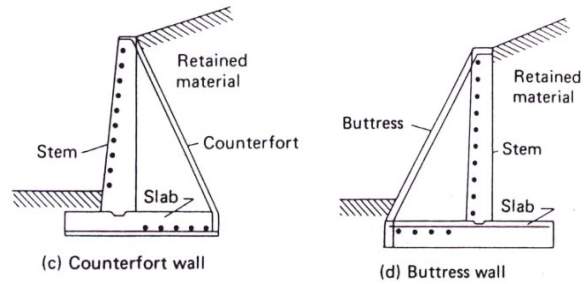

Loads

The design of retaining walls must consider overturning, settlement, sliding and bearing pressure. The water in the retained soil can significantly affect the loading and the active pressure of the soil. The lateral force, P, acting at a height of h/3 is determined from the equivalent fluid weight (density), ω', (in force/cubic area) as:

$$P = \frac{\omega'h^2}{2} \text{ or } \frac{ph}{2}$$

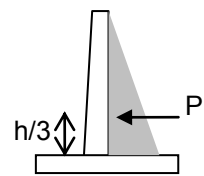

where p is the maximum pressure at the base: $p = \omega' \cdot h$

Overturning is considered the same as for eccentric footings:

$$SF = \frac{M_{resist}}{M_{overturning}} \geq 1.5 - 2$$

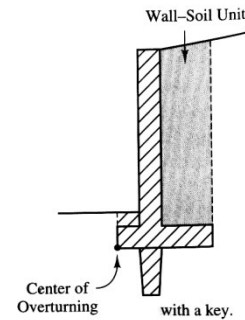

where

M_{resist} = summation of moments about “o” to resist rotation, typically including the moment due to the weight of the stem and base and the moment due to the passive pressure.

$M_{overturning}$ = moment due to the active pressure about the toe “o”.

Sliding must also be avoided:

$$SF = \frac{F_{horizontal+resist}}{F_{sliding}} \geq 1.25 - 2$$

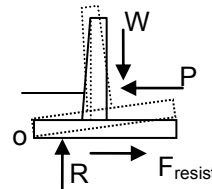

where

$F_{horizontal-resist}$ = summation of forces to resist sliding, typically including the force from the passive pressure and friction ($F = \mu \cdot N$ where μ is a constant for the materials in contact and N is the normal force to the ground acting down and is shown as R).

$F_{sliding}$ = sliding force as a result of active pressure.

Pressure Distribution

Because the resultant force from the gravity loads and pressure is not vertical, the vertical pressure distribution under the footing will not be uniform, but will be linearly distributed. The vertical component of the resultant must be in the same horizontal location as the pressure reaction force.

- There can never be a tensile pressure because the footing will not be in contact with the soil.
- To make certain all the area under the footing is used to distributed the load, the vertical resultant needs to be within the middle third of the base width. This area is called the *kern*.
- Soil pressure is most commonly called *q* in the design texts and codes.

To determine the size of the maximum pressure we find the equivalent location of the pressure reaction, P, at x using moment calculations when $R_x = W$:

$$W = P = 1/2p(3x)$$

so $p = 2W/3x$ when $x < a/3$

$p = 2W/a$ when $x = a/3$

and $p = \frac{W}{a^2} (4a - 6x)$ when $a/3 < x < 2a/3$

$$x = \frac{M_{resisting} - M_{overturning}}{W_{total}}$$

where x is the location of the resultant force and a is the width of the base.

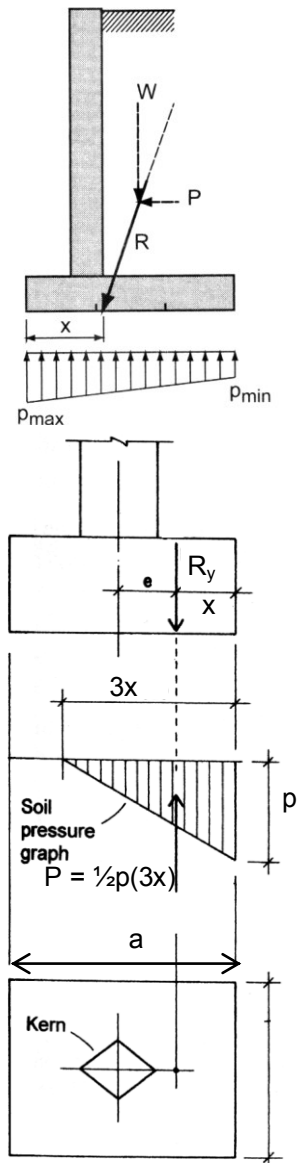

Wind Load Tracing

For design purposes, wind loads are treated as static pressure distributions over the walls and roof. In the case of walls, the loads are traced just like those for horizontal surfaces. If there is a roof diaphragm, it is the “top” supporting element and the tributary boundary is half way “up” to the diaphragm. If the supporting elements are the side walls the tributary boundary is vertical and half way between sides. In either case, the traced action force at the top of the walls is a lateral *shear* force (V) that must be resisted. The shear over the width of a shear wall, v, is a *unit shear* used for determining the connection and framing capacity required.

Lateral Resisting Systems

- Shear Walls
- Braced Frames
- Rigid Frames
- Diaphragms
- Cores
- Tubes

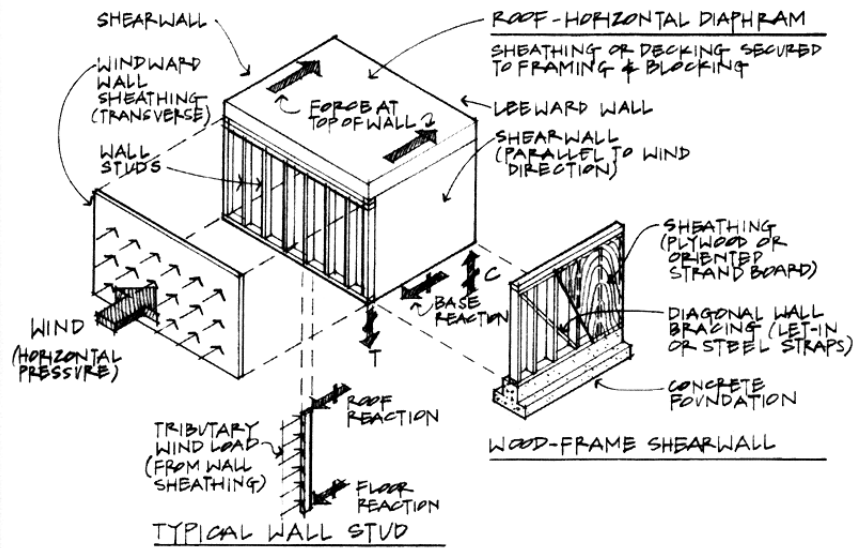

Figure 4.48 Exploded view of a light-framed wood building showing the various lateral resisting components.

Bracing Configurations

Without proper arrangement of the lateral resisting components, the system cannot transfer lateral loads that may come from any direction.

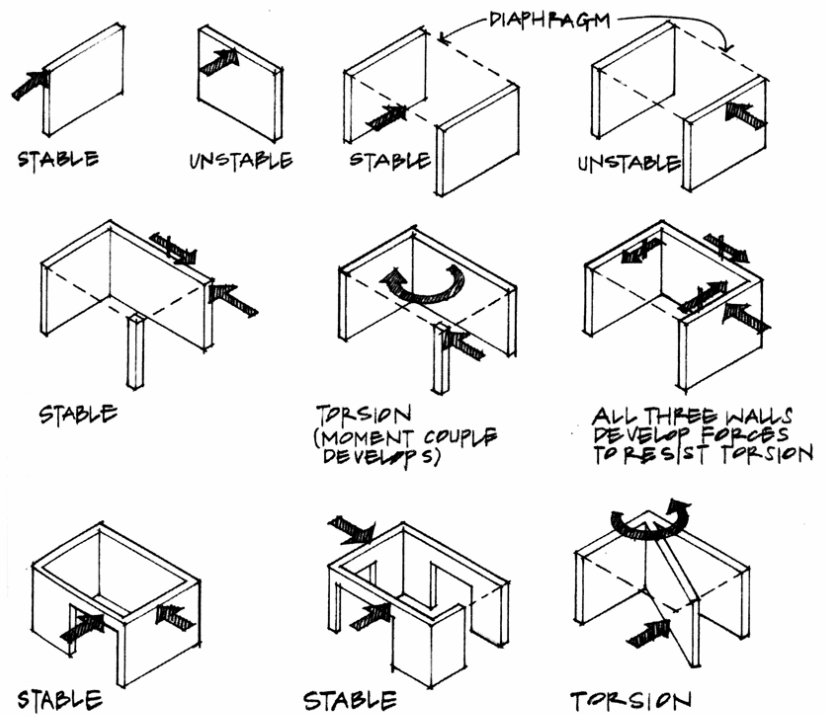
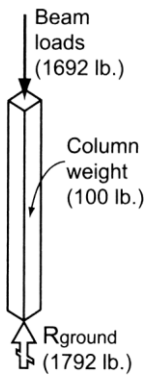
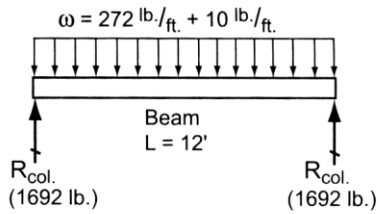
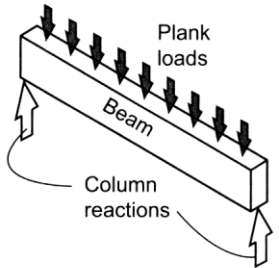
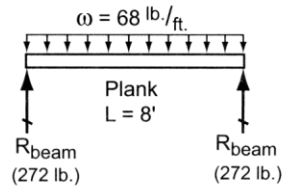
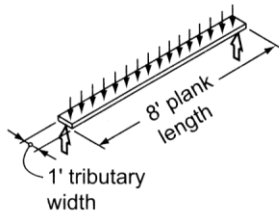
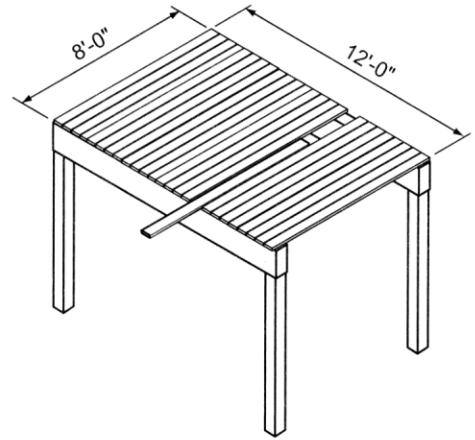

Figure 4.54 Various shearwall arrangements—some stable, others unstable.

Example 1 (pg 168)
Example Problem 5.2

In the single-bay, post-and-beam deck illustrated, planks typically are available in nominal widths of 4" or 6", but for the purposes of analysis it is permissible to assume a unit width equal to one foot. Determine the plank, beam, and column reactions.

The loads are: 60 lb/ft² live load, 8 lb/ft² dead load, 10 lb/ft self weight of 12' beams, and 100 lb self weight of columns.



Example 2

EXAMPLE

Assume that the average dead plus live load on the structure shown in Figure 3.15 is 60 lbs/ft². Determine the reactions for Beam D. This is the same structure as shown in Figure 3.1.

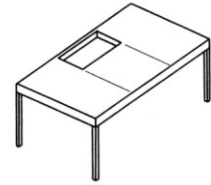
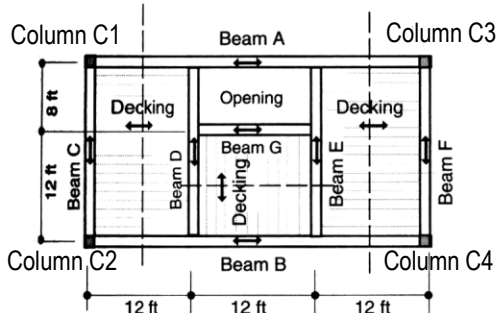

Figure 3.1

Solution:

Note carefully the directions of the decking span. Beam D carries floor loads from the decking to the left (see the contributory area and load strip), but not to the right, since the

^ E, B and A Assuming all beams are weightless!



Load strip for Beam D = 6 ft (60 lbs/ft²) = 360 lb/ft
Contributory load area for Beam D

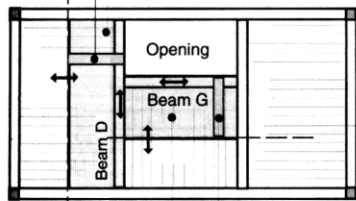

Contributory load area for Beam G Load strip for Beam G = 6 ft (60 lbs/ft²) = 360 lb/ft

Live and dead load

Assume $w_{DL+LL} = 60 \text{ lbs/ft}^2$

Beam G carries distributed loads only

Find reactions for Beam G

$W = 6 \text{ ft} (60 \text{ lbs/ft}^2) = 360 \text{ lb/ft}$

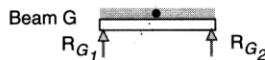

$R_{G1} = wL/2 = (360 \text{ lb/ft})(12 \text{ ft})/2 = 2160 \text{ lbs}$

$R_{G2} = wL/2 = (360 \text{ lb/ft})(12 \text{ ft})/2 = 2160 \text{ lbs}$

Beam D carries both distributed loads and the reaction R_{G1} from Beam G

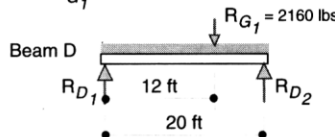

$\Sigma M_{D1} = 0$

$-(12 \text{ ft})(2160 \text{ lb}) - (360 \text{ lb/ft})(20 \text{ ft})(20 \text{ ft}/2) + 20 R_{D2} = 0$

$R_{D2} = 4896 \text{ lb} = R_{E2}$

$\Sigma F_y = 0$

$R_{D1} + R_{D2} = (360 \text{ lb/ft})(20 \text{ ft}) + 2160 \text{ lb}$

$R_{D1} = 4464 \text{ lb} = R_{E1}$

FIGURE 3.15 Load modeling and reaction determination.

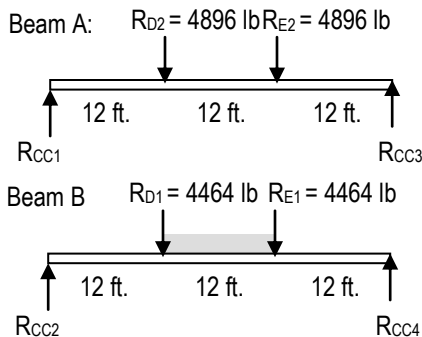

By symmetry; $R_{C1} = R_{C3} = (4896 \text{ lb} + 4896 \text{ lb})/2 = 4896 \text{ lb}$

By symmetry; $R_{C2} = R_{C4} = (4464 \text{ lb} + 4464 \text{ lb})/2 + (6 \text{ ft})(60 \text{ lb/ft}^2)(12 \text{ ft})/2 = 6624 \text{ lb}$

Additional loads are transferred to the column from the reactions on Beams C and F:
 $R_{C1} = R_{C2} = R_{F1} = R_{F2} = wL/2 = (6 \text{ ft})(60 \text{ lb/ft}^2)(20 \text{ ft})/2 = 3600 \text{ lb}$

center decking runs parallel to Beam D and is not carried by it. Beam D also picks up the end of Beam G and thus also “carries” the reactive force from Beam G. It is therefore necessary to analyze Beam G first to determine the magnitude of this force. The analysis appears in Figure 3.15. The reactive force from Beam G of 2160 lbs is then treated as a downward force acting on Beam D. The load model for Beam D thus consists of distributed forces from the decking plus the 2160-lb force. It is then analyzed by means of the equations of statics to obtain reactive forces of 4896 lbs and 4464 lbs at its ends.

- C1 = 4896 lb + 3600 lb = 8,496 lb
- C2 = 6624 lb + 3600 lb = 10,224 lb
- C3 = 4896 lb + 3600 lb = 8,496 lb
- C4 = 6624 lb + 3600 lb = 10,224 lb

Example 3

Determine the factor of safety for overturning and sliding on the 15 ft. retaining wall, 16 in. wide stem, 10 ft. wide x 16 in. high base, when the equivalent fluid pressure is 30 lb/ft^3 , the weight of the stem of the footing is 4 kips, the weight of the pad is 5 kips, the passive pressure is ignored for this design, and the friction coefficient for sliding is 0.58. The center of the stem is located 3 ft. from the toe. Also find the maximum bearing pressure.

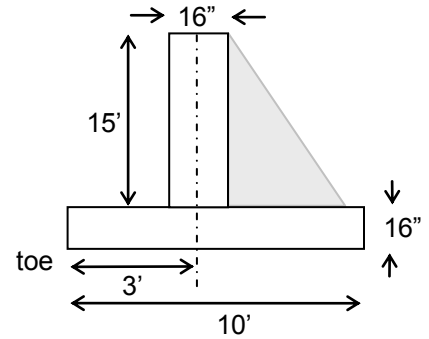

Example 4

4.10 A beach cabin on the Washington coast (100 mph wind velocity) is required to resist a wind pressure of 35 psf. Assuming wood-frame construction, the cabin utilizes a roof diaphragm and four exterior shearwalls for its lateral resisting strategy.

Draw an exploded view of the building and perform a lateral load trace in the N-S direction. Show the magnitude of shear (V) and intensity of shear (v) for the roof and critical shearwall. Also, determine the theoretical tie-down force necessary to establish equilibrium of the shearwall. Note that the dead weight of the wall can be used to aid in the stabilizing of the wall.

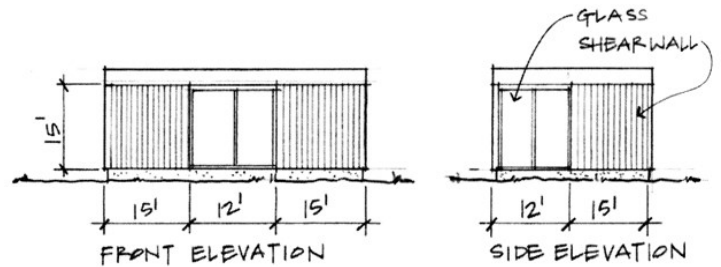
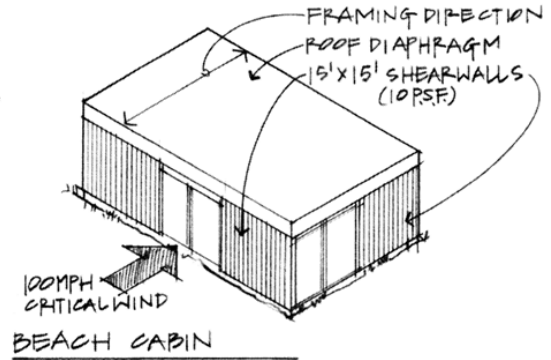

Solution:

$$\omega = 35 \text{ psf} \times 7.5' = 262.5 \text{ \#/ft.}$$

Examining the roof diaphragm as a deep beam spanning 42' between shearwalls:

$$V = \frac{\omega L}{2} = \frac{262.5 \text{ \#/ft.} (42')}{2} = 5,513 \#$$

An FBD of the shearwall shows a shear V' developing at the base (foundation) to equilibrate the shear V at the top of the wall. In addition to equilibrium in the horizontal direction, rotational equilibrium must be maintained by the development of a force couple T and C at the edges of the solid portion of wall.

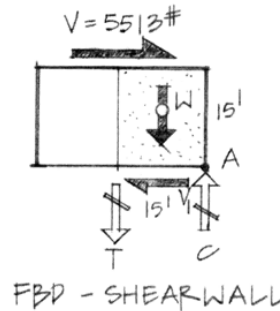

$$v = V/\text{shearwall length} = 5,513 \#/15' = 368 \#/\text{ft.}$$

W = dead load of the wall

$$W = 10 \text{ psf} \times 15' \times 15' = 2,250 \#$$

Tie-down force T is determined by writing a moment equation of equilibrium. Summing moments about point A:

$$[\sum M_A = 0] - V (15') + W (15'/2) + T (15') = 0$$

$$15 T = 5,513\#(15') - 2,250\#(7.5')$$

$$T = \frac{(82,695 \text{ \#.ft.}) - (16,875 \text{ \#.ft.})}{15}$$

$$T = 4,390 \#$$

