

Rigid and Braced Frames

Notation:

<p>E = modulus of elasticity or Young's modulus</p> <p>F_x = force component in the x direction</p> <p>F_y = force component in the y direction</p> <p>FBD = free body diagram</p> <p>G = relative stiffness of columns to beams in a rigid connection, as is Ψ</p> <p>I = moment of inertia with respect to neutral axis bending</p>	<p>k = effective length factor for columns</p> <p>l_b = length of beam in rigid joint</p> <p>l_c = length of column in rigid joint</p> <p>L = name for length</p> <p>M = internal bending moment</p> <p>= name for a moment vector</p> <p>V = internal shear force</p> <p>Σ = summation symbol</p>
---	--

Rigid Frames

Rigid frames are identified by the lack of pinned joints within the frame. The joints are *rigid* and resist rotation. They may be supported by pins or fixed supports. They are typically statically indeterminate.

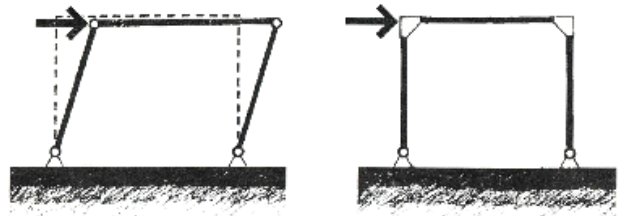

Frames are useful to resist **lateral** loads.

Frame members will see

- shear
- bending
- axial forces

and behave like *beam-columns*.

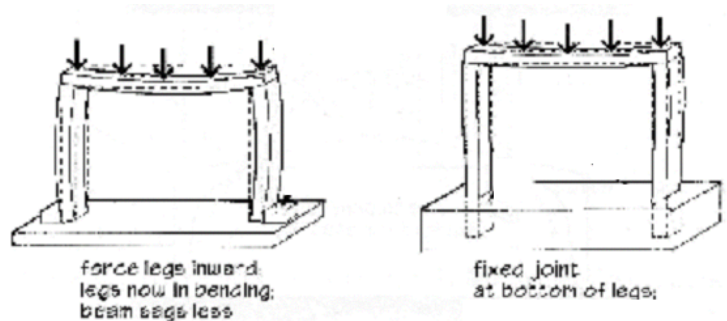

Behavior

The relation between the joints has to be maintained, but the whole joint can *rotate*. The amount of rotation and distribution of moment depends on the *stiffness* (EI/L) of the members in the joint.

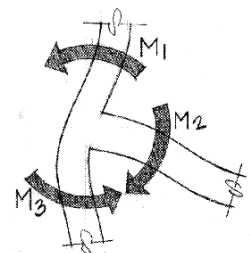

End restraints on columns reduce the effective length, allowing columns to be more slender. Because of the rigid joints, deflections and moments in beams are reduced as well.

Frames are sensitive to settlement because it induces strains and changes the stress distribution.

Types

Gabled – has a peak

Portal – resembles a door. Multi-story, multiple bay portal frames are commonly used for commercial and industrial construction. The floor behavior is similar to that of continuous beams.

Staggered Truss – Full story trusses are staggered through the frame bays, allowing larger clear stories.

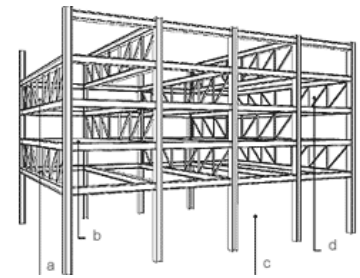

Staggered Truss

Connections

Steel – Flanges of members are fully attached to the flanges of the other member. This can be done with welding, or bolted plates.

Reinforced Concrete – Joints are monolithic with continuous reinforcement for bending. Shear is resisted with stirrups and ties.

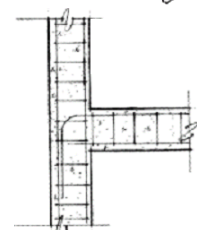
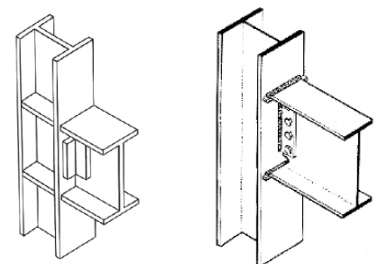

Braced Frames

Braced frames have beams and columns that are “pin” connected with bracing to resist lateral loads.

Types of Bracing

- knee-bracing
- diagonal (including eccentric)
- X
- K or chevron
- shear walls – which resist lateral forces in the plane of the wall

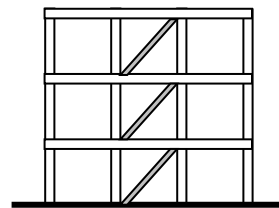
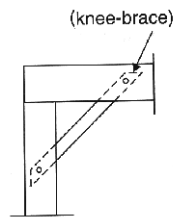

diagonal

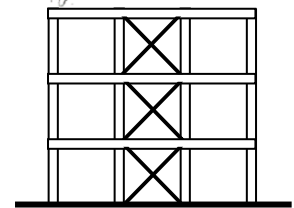

X

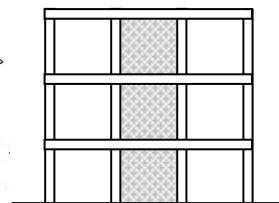
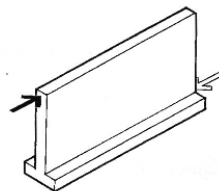

shear walls

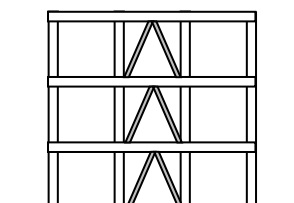

K (chevron)

Rigid Frame Analysis

Structural analysis methods such as the *portal method* (approximate), the *method of virtual work*, *Castigliano’s theorem*, the *force method*, the *slope-displacement method*, the *stiffness method*, and *matrix analysis*, can be used to solve for internal forces and moments and support reactions.

Shear and bending moment diagrams can be drawn for frame members by isolating the member from a joint and drawing a free body diagram. The internal forces at the end will be equal and opposite, just like for connections in *pinned frames*. Direction of the “beam-like” member is usually drawn by looking from the “inside” of the frame.

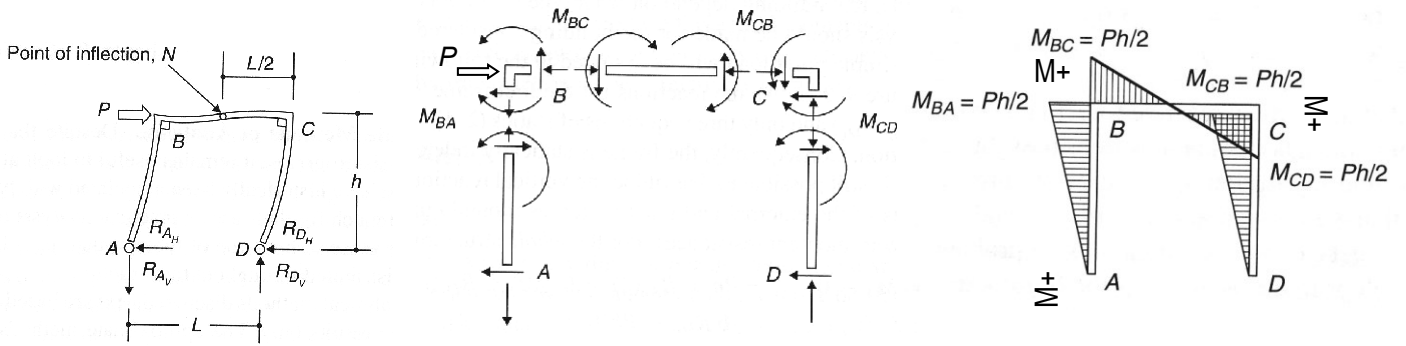

Frame Columns

Because joints can rotate in frames, the effective length of the column in a frame is harder to determine. The stiffness (EI/L) of each member in a joint determines how rigid or flexible it is. To find k , the relative stiffness, G or Ψ , must be found for both ends, plotted on the alignment charts, and connected by a line for braced and unbraced frames.

$$G = \Psi = \frac{\sum EI/l_c}{\sum EI/l_b}$$

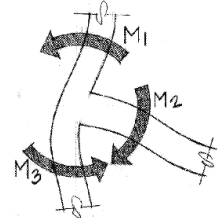

where

- E = modulus of elasticity for a member
- I = moment of inertia of for a member
- l_c = length of the column from center to center
- l_b = length of the beam from center to center

- For pinned connections we typically use a value of 10 for Ψ .
- For fixed connections we typically use a value of 1 for Ψ .

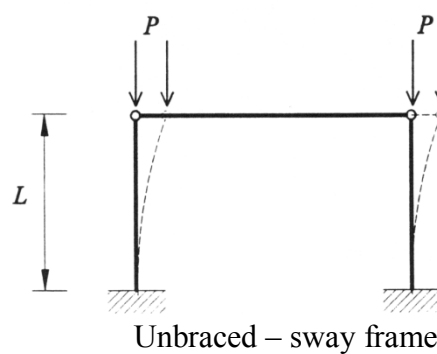
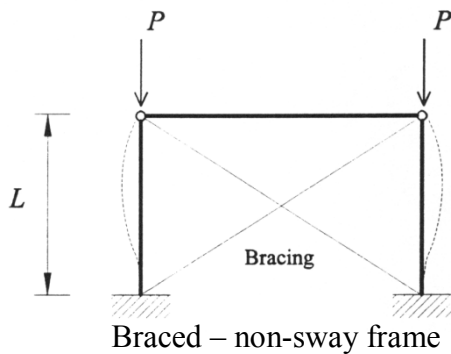

Frame Design

The possible load combinations for frames with dead load, live load, wind load, etc. is critical to the design. The maximum moments (positive and negative) may be found from different combinations and at different locations. Lateral wind loads can significantly affect the maximum moments.

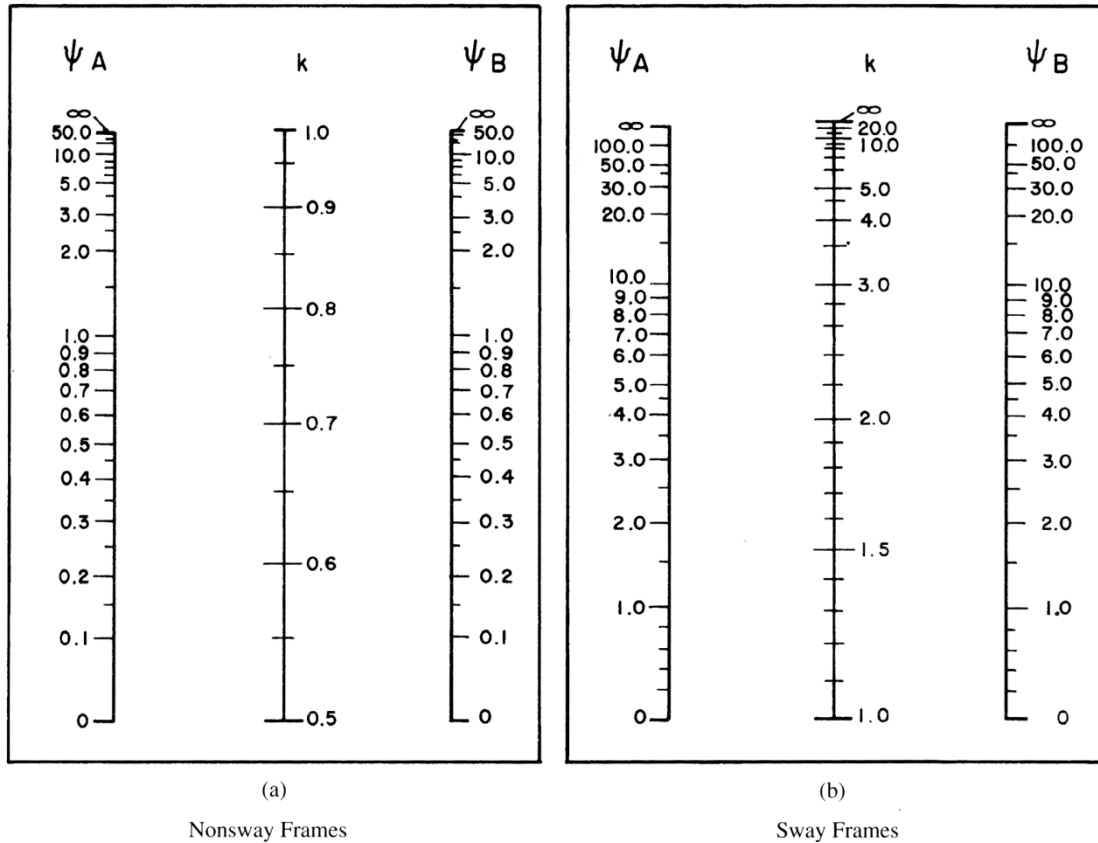

Plates and Slabs

If the frame is rigid or non-rigid, the floors can be a plate or slab (which has drop panels around columns). These elements behave differently depending on their supports and the ratio of the sides.

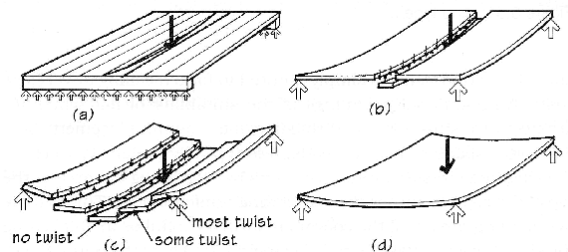

- one-way behavior: like a “wide” beam, when ratio of sides > 1.5
- two-way behavior: complex, non-determinate, look for handbook solutions

Floor Loading Patterns

With continuous beams or floors, the worst case loading typically occurs when alternate spans are loaded with live load (not every span). The maximum positive and negative moments may not be found for the same loading case! If you are designing with reinforced concrete, you must provide flexure reinforcement on the top and bottom and take into consideration that the maximum may move.

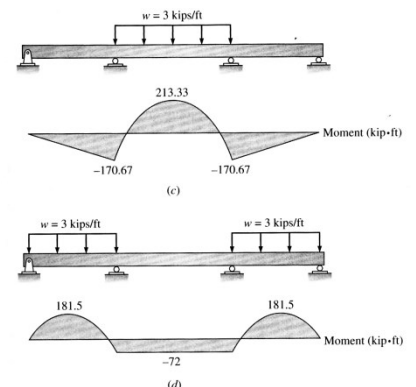

Example 1

The rigid frame shown has been analyzed using an advanced structural analysis technique. The reactions at support A are: $A_x = -28.6$ k, $A_y = -15.3$ k, $M_A = 208$ k-ft. The reactions at support D are: $D_x = -11.4$ k, $D_y = 15.3$ k, $M_D = 110$ ft-k. Draw the shear and bending moment diagrams, and identify V_{max} & M_{max} .

Solution:

NOTE: The joints are not shown, and the load at joint B is put on only one body.

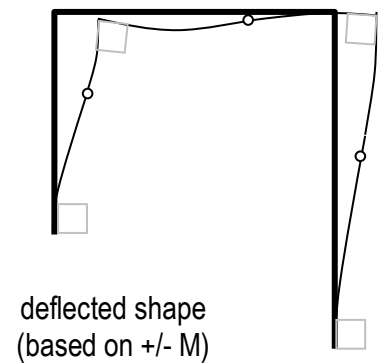
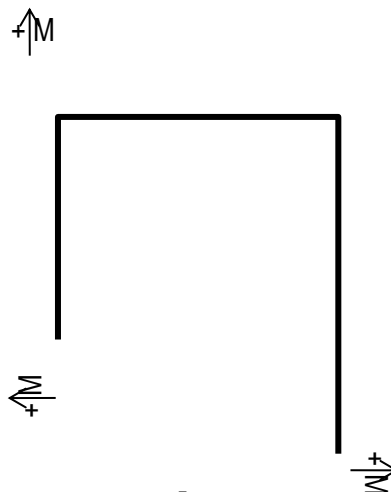
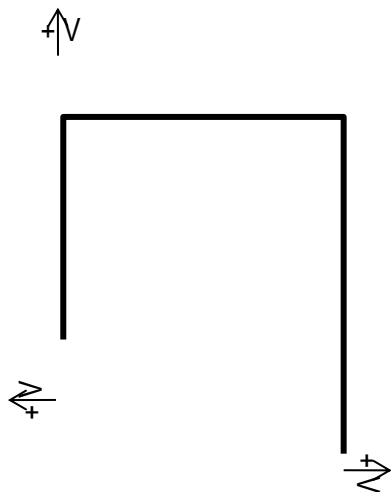
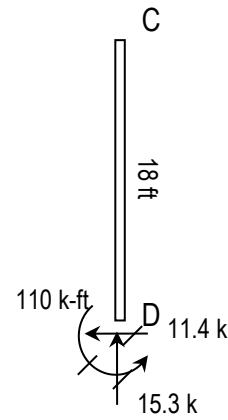
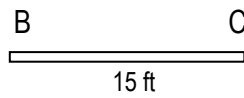
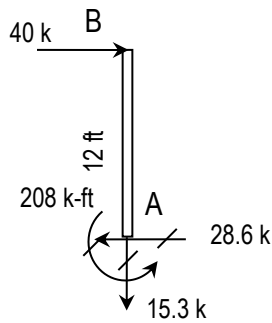
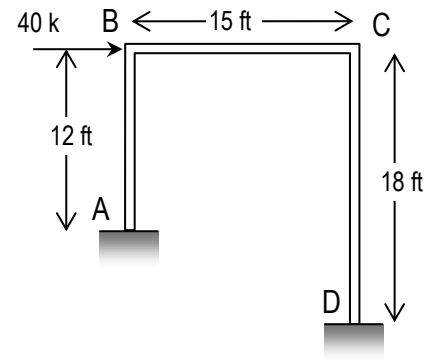

Example 2

The rigid frame shown has been analyzed using an advanced structural analysis technique. The reactions at support A are: $A_x = 2.37 \text{ kN}$, $A_y = 21.59 \text{ kN}$, $M_A = -4.74 \text{ kN}\cdot\text{m}$. The reactions at support C are: $C_x = -2.37 \text{ kN}$, $C_y = 28.4 \text{ kN}$, $M_C = -26.52 \text{ kN}\cdot\text{m}$. Draw the shear and bending moment diagrams, and identify V_{\max} & M_{\max} .

Solution:

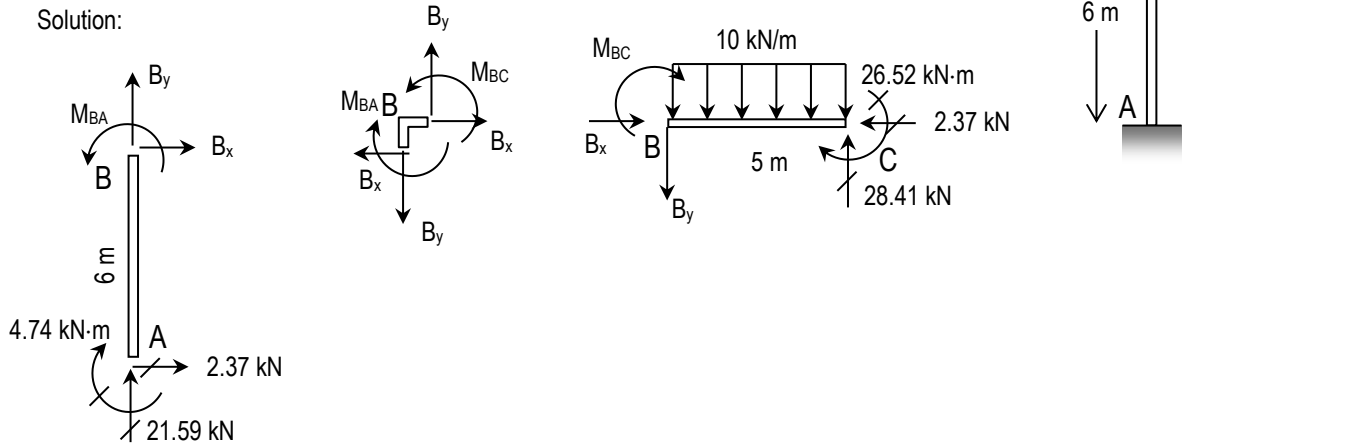

Reactions These values must be given or found from non-static analysis techniques. The values are given with respect to the global coordinate system we defined for positive and negative forces and moments for equilibrium.

Member End Forces The free-body diagrams of all the members and joints of the frame are shown above. The unknowns on the members are drawn positive on one body for a joint, and the opposite directions are drawn on the other body of for the joint. We can begin the computation of internal forces with either member AB or BC, both of which have only three unknowns.

Member AB With the magnitudes of reaction forces at A known, the unknowns are at end B of B_x , B_y , and M_{BA} , which can get determined by applying $\sum F_x = 0$, $\sum F_y = 0$, and $\sum M_B = 0$. Thus,

$$\sum F_x = 2.37 \text{ kN} + B_x = 0 \quad B_x = -2.37 \text{ kN}, \quad \sum F_y = 21.59 \text{ kN} + B_y = 0 \quad B_y = -21.59 \text{ kN}$$

$$\sum M_B = 2.37 \text{ kN}(6 \text{ m}) - 4.74 \text{ kN}\cdot\text{m} + M_{BA} = 0 \quad M_{BA} = -9.48 \text{ kN}\cdot\text{m}$$

Joint B The joint is shown to illustrate that the forces and moments on the cuts will be equal and opposite, resulting in the forces and moment at joint be on body BC to be opposite from those on body AB: $B_x = 2.37 \text{ kN}$, $B_y = -21.59 \text{ kN}$ and $M_{BC} = -9.48 \text{ kN}\cdot\text{m}$

Member BC All forces are known, so equilibrium can be checked:

$$\sum F_x = 2.37 \text{ kN} - 2.37 \text{ kN} = 0 \quad \sum F_y = 21.59 \text{ kN} + 28.49 \text{ kN} - (10 \text{ kN} / \text{m})5 \text{ m} = 0$$

$$\sum M_B = 28.41 \text{ kN}(5 \text{ m}) - 10 \text{ kN} / \text{m}(5 \text{ m})(2.5 \text{ m}) - 26.52 \text{ kN}\cdot\text{m} + 9.48 \text{ kN}\cdot\text{m} = 0$$

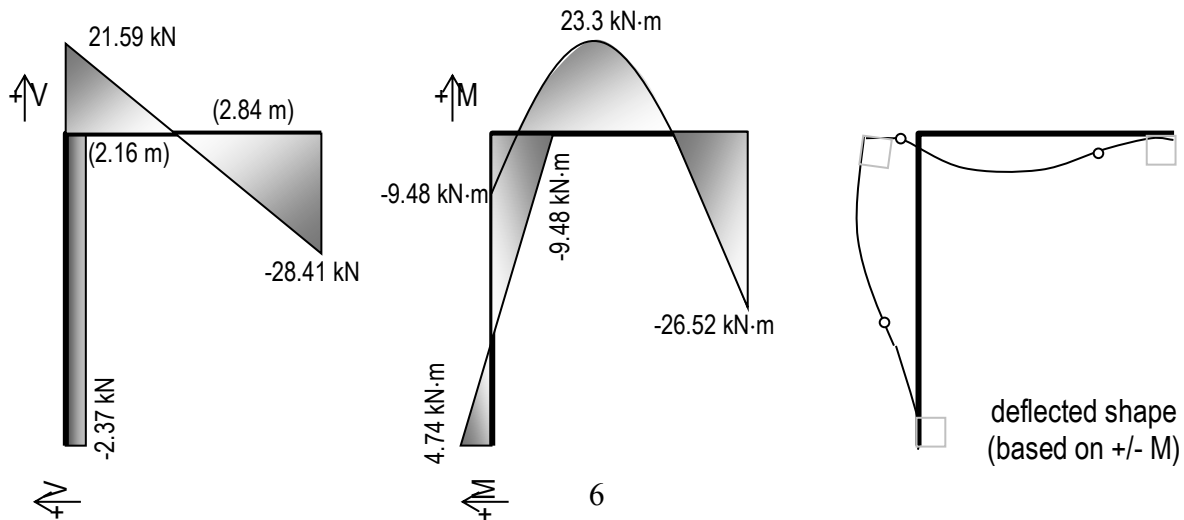

Example 4

The rigid frame shown has been analyzed using an advanced structural analysis technique. The reactions at support A are: $A_x = -3.42 \text{ kN}$, $A_y = -5.44 \text{ kN}$, $M_A = 12.63 \text{ kN}\cdot\text{m}$. The reactions at support D are: $D_x = 7.42 \text{ kN}$, $D_y = 25.44 \text{ kN}$, $M_D = -6.12 \text{ kN}\cdot\text{m}$. Draw the shear and bending moment diagrams, and identify V_{max} & M_{max} .

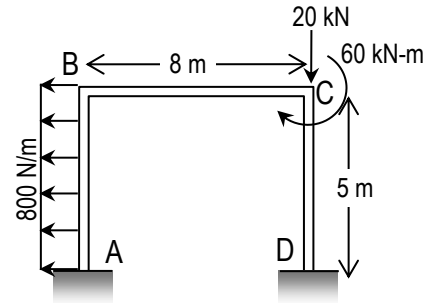

Solution:

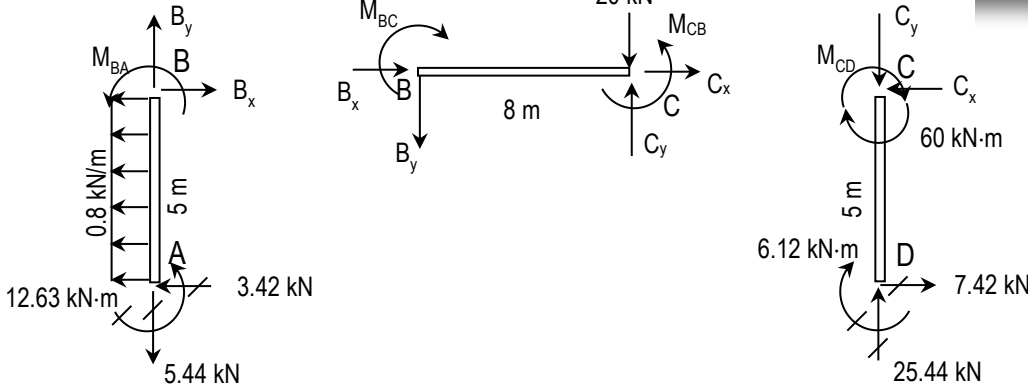

Reactions The values given were found from non-static analysis techniques and put on the FBD's.

Member End Forces The free-body diagrams of all the members and joints of the frame are shown above assuming joint force directions on one body and opposite directions on the joining body. Because there is a force and moment at C, these must be put on only one body of the joint, and it doesn't matter which body.

Member AB $\sum F_x = -3.42 \text{ kN} - 0.8 \text{ kN} / \text{m} \cdot 5 \text{ m} + B_x = 0 \quad B_x = -7.42 \text{ kN}$
 $\sum F_y = -5.44 \text{ kN} + B_y = 0 \quad B_y = 5.44 \text{ kN}$
 $\sum M_B = -3.42 \text{ kN}(5 \text{ m}) - 0.8 \text{ kN} / \text{m}(5 \text{ m})(2.5 \text{ m}) + 12.63 \text{ kN} \cdot \text{m} + M_{BA} = 0 \quad M_{BA} = 14.47 \text{ kN}\cdot\text{m}$

Joint B $M_{BA} = M_{BC} = 14.47 \text{ kN}\cdot\text{m}$

Member BC $\sum F_x = -7.42 \text{ kN} + C_x = 0 \quad C_x = 7.42 \text{ kN}$
 $\sum F_y = -5.44 \text{ kN} + C_y = 0 \quad C_y = 5.44 \text{ kN}$
 $\sum M_C = -14.47 \text{ kN} \cdot \text{m} + 5.44 \text{ kN}(8 \text{ m}) + M_{CB} = 0 \quad M_{CB} = -29.05 \text{ kN}\cdot\text{m}$

Joint C $M_{CB} = M_{CD} = -29.05 \text{ kN}\cdot\text{m}$

Member CD $\sum F_x = -7.42 \text{ kN} + 7.42 \text{ kN} = 0$
 (checking) $\sum F_y = -5.44 \text{ kN} - 20 \text{ kN} + 25.44 \text{ kN} = 0$
 $\sum M_C = -(-29.05 \text{ kN} \cdot \text{m}) - 60 \text{ kN} \cdot \text{m} - 6.12 \text{ kN} \cdot \text{m} + 7.42 \text{ kN}(5 \text{ m}) = 0$

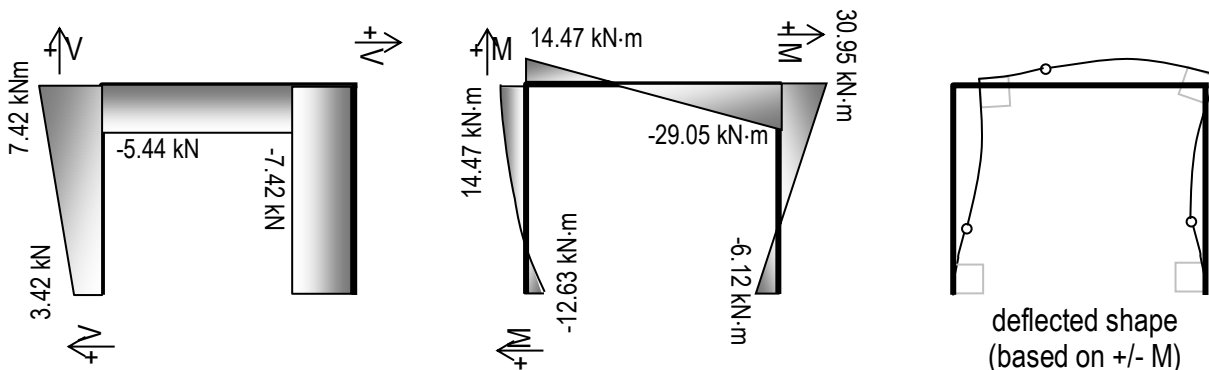

Example 5

Find the column effective lengths for a steel frame with 12 ft columns, a 15 ft beam when the support connections are pins for a) when it is braced and b) when it is allowed to sway. The relative stiffness of the beam is twice that of the columns ($2I$).

